

EUROstil
PROFESIONAL

TASSEL
PROFESIONAL HAIR COSMETICS

**Especial
peluquería
Special
hairdressing**

Sin precio / Without prices

Pollié

lacla

Ondina

ETI

PEGASUS

Lerioti
MADE IN ITALY

TRAMUNTANA

MEDITERRÁNEO

SILKOMB

BERGMANN
HAIR AND MORE...

MATADOR
PROFESIONAL

Valera

REMINGTON

**INDUSTRIAS
ORIO** 1942 S.L.U.
PELUQUERÍA - BARBERÍA - ESTÉTICA - COSMÉTICA

www.eurostil.com

01 Eléctricos Electrics 4

Secadores · Hair dryers	5
Difusores · Diffusers	22
Activadores · Thermo stimulators	24
Secadores de casco y Vaporizadores Cerotti Helmet hair dryers and Cerrotti Vaporizers	26
Secadores de casco y Vaporizadores Eurostil Helmet hair dryers and Eurostil Vaporizers	29
Casco Secador Valera · Valera helmet hair dryer	30
Planchas · Hair straighteners	31
Tenacillas Rizadoras · Curling tongs	42
Mezclador tinte · Dyeing mixer	49
Esterilizadores · Sterilizers	50
Aspiradores de cabello · Hair vacuums	53

02 Artículos tintura Dyeing accessories 54

Accesorios tinte · Dyeing accessories	55
Tiras mechas · Streak strips	57
Temporizadores · Timers	58
Balanzas · Scales	59
Bols · Bowls	60
Paletinas · Dyeing brushes	64
Protectores lavacabezas y jofainas Protection & neck tray	70
Cocteleras y mediadores · Shakes and measures	71
Papel aluminio · Aluminium foil	73
Protectores · Dye protectors	76
Guantes · Gloves	77
Peinadores · Gowns	80
Capas · Capes	82
Delantales · Aprons	99
Capas infantiles · Kids capes	100
Vestuario LACLA · LACLA clothing	102

03 Cosmética capilar Hair cosmetics 116

Tinte Bright colour · Bright colour dye	117
Tinte capilar sin amoníaco · Ammonia free hair dye	124
Mascarillas · Mask	126
Oxidante capilar · Hair oxidant	128
Tinte capilar · Hair dye	132
Decolorantes · Bleaching powder	135
Línea natural Botanical · Botanical natural line	138
Champús y mascarillas · Shampoos and masks	140
Aroma Sensation · Aroma Sensation	144
Champús y mascarillas · Shampoos and masks	149
Productos de acabado y fibras capilares Finishing products and hair fibers	154

04 Clips y pinzas Clips & clamps 164

Clips · Clips	165
Horquillas · Hairpins	170
Pinzas · Clips	177
Grapas · Hair grips	186
Gomas y coileteros · Elastic hair bands	188
Turbantes · Turbans	195
Clips con perlas · Hair grips with pearls	196

05 Papel Paper 198

Toallas celulosa y spunlace Cellulose towels and spunlace	199
Papel · Paper	200
Papel permanente · Pop-up paper	201

06 Formación Training 202

Cabezas de maniquí cabello natural Mannequin heads natural hair	203
Cabezas de maniquí cabello sintético Mannequin heads synthetic hair	208
Cabezas maniquí Bergmann Mannequin heads Bergmann	210
Soportes y trípodes · Holders and tripods	211

07 Mobiliario Furniture 212

Mostradores y espejos · Front desks and mirrors	213
Sillas para niños · Children's seats	215
Taburetes · Stools	217
Sillas · Chairs	219
Lavacabezas · Wash basin	220
Sillas y sillones peluquería Chairs and armchairs hairdressing	226
Lavacabezas portátiles · Portable wash basin	234
Carritos · Trolley	236
Varios · Various	239

08 Peines y cepillos Combs & hair brushes 242

Cepillos crear · Crimping brushes	243
Cepillos espirales · Round brushes	244
Cepillos circulares mango madera Round brushes wooden handle	245
Cepillos fuelle mango madera Cushion brushes wooden handle	249
Cepillo fuelle desenredar Detangler cushion brush	253
Cepillo fuelle mango plástico Cushion brush plastic handle	254
Cepillos fuelle mango goma Cushion brush rubber handle	260
Cepillo desenredar · Detangler brushes	263
Expositores cepillos · Brushes display	264
Cepillos esqueletos · Vent brushes	265
Cepillos planos desenredar · Plastic flat detangler brush	273
Peines lendreras y cepillos baby · Nit and baby combs	275
Cepillos térmicos, iónicos, cerámicos y cromáticos Ceramic, ionic, thermal, cromatic brushes	277
Peines prof. EUROSTIL · EUROSTIL professional combs	283
Peines Carbono · Carbon combs	295
Estuches peines · Combs sets	398
Peines PEGASUS · PEGASUS combs	300
Peines prof. POLLIÉ · POLLIÉ professional combs	301
Peines prof. MATADOR · MATADOR professional combs	303
Peines prof. SILKOMB · SILKOMB professional combs	306
Peines varios colores · Various colours combs	307
Botes peines colores · Combs bins	311
Peines color madera · Wooden colour combs	316
Peines ahuecador · Styling combs	318
Peines acetato · Acetat combs	320
Línea de productos de material reciclado Recycled material product line	323

09 Rulos, rellenos y gorros Rollers, fillings and caps 326

Bigudíes madera · Wooden hair curlers	327
Bigudíes plástico · Plastic hair curlers	328
Papillots · Coils	331
Rulos · Rollers	332
Gorros y redes · Caps and hairnets	340
Rellenos de moño · Hair bun stuff	349

11 Extensiones de pelo Hair extensions 376

Cortinas cabello · Hair wefts	377
Anillas · Aluminum rings	378
Clips · Clips	379
Varios · Various	380

10 Tijeras Scissors 354

Tijeras titanio y decoradas	355
<i>Titanium and decorated scissors</i>	
Tijeras profesionales Premium	357
<i>Premium Professional scissors</i>	
Tijeras zurdos · Left-handed scissors	362
Tijeras profesionales · Professional scissors	363
Tijeras iniciación · Initiation scissors	368
Estuches tijeras · Scissors set	370
Corta-cabellos y navajas	373
<i>Hair cutter and razors</i>	

12 Varios Various 382

Algodón · Cotton	383
Maletas y bolsas · Cases	384
Portaútiles · Purses for tools	393
Facepro · Facepro	395
Varios · Various	396
Porta pelucas · Wig holder	397
Pulverizadores · Sprayers	397
Toallas · Towels	400
Limpieza e higiene · Hygiene items	401

Los precios que figuran en este catálogo son precios recomendados, impuestos no incluidos.
Los precios serán vigentes salvo errores tipográficos.
Industrias Oriol 1942, S.L. se reserva el derecho a realizar modificaciones sin previo aviso.

*The prices in the catalog are intended for professionals and do not include VAT.
Prices are up to date unless there is a typographical error.
Industrias Oriol 1942 S.L. reserves the right to make changes without notice.*



01



Artículos eléctricos Electric appliances

*Secadores, planchas, tenacillas,
activadores, secadores de casco...*

*Hair dryers, hair straighteners,
curlings, activators, helmet hair dryers...*

Secador DISCOVERY

DISCOVERY hair dryer

u.m.vta: 1  1 

REF. 07556

Generador de iones
Suaviza e hidrata el cabello,
reduciendo el tiempo de secado.

Ion generator
Softens and hydrates the hair,
reducing drying times





- Potencia: 1900W
- Motor compacto de diseño digital sin escobillas de larga duración
- Peso: 390 g
- Caudal de aire 86,4 m³/h
- 5 temperaturas
- Botón de aire frío
- 2 boquillas orientables medidas media 65 mm y grande 85 mm
- Termostato de seguridad
- Filtro acero inoxidable
- Cable extra flexible de 3.5m
- Nivel sonoro 80Db
- Voltaje 220-240V~
- Frecuencia: 50Hz
- Diseño ergonómico
- Carcasa robusta y ligera de policarbonato
- Generador de iones, que suaviza e hidrata el cabello, reduciendo el tiempo de secado
- Difusor para cabellos rizados
- Dispositivo de seguridad que se acciona automáticamente en caso del mal funcionamiento del aparato
- Apto para cualquier tipo de cabello natural

- Power: 1900W
- Compact, long-life digital brushless motor design
- Weight: 390 g
- Air flow rate 86,4 m³/hour
- 5 temperatures
- Cold air button
- 2 adjustable nozzles. Measurements: medium (65 mm)/large (85 mm).
- Extra flexible 3.5 m cable
- Safety thermostat
- Stainless-steel filter
- Low noise level: 80 Db
- Voltage 220-240V ~
- Frequency: 50Hz
- Ergonomic design
- Robust and lightweight polycarbonate housing
- Ion generator, which softens and hydrates the hair, reducing drying times
- Diffuser for curly hair
- The device has a safety device, which triggers in case of malfunction
- Suitable for any type of natural hair

Secador EVOLUTION

EVOLUTION hair dryer

u.m.vta: 1  1 

REF. 07553



Más
información
More
information

SCAN
ME!





- Potencia: 1600-1700W
- Motor compacto de diseño digital sin escobillas de larga duración
- Peso: 360 g
- Caudal de aire 86,4 m³/h
- 5 temperaturas
- Botón de aire frío
- 2 boquillas orientables medidas media y grande
- Termostato de seguridad
- Filtro acero inoxidable
- Cable extra flexible de 3m
- Nivel sonoro 80Db
- Voltaje 220-240V~
- Frecuencia: 50Hz
- Diseño ergonómico
- Carcasa robusta y ligera de policarbonato
- Generador de iones, que suaviza e hidrata el cabello, reduciendo el tiempo de secado
- Difusor para cabellos rizados
- Dispositivo de seguridad que se acciona automáticamente en caso del mal funcionamiento del aparato
- Apto para cualquier tipo de cabello natural

- Power: 1600 - 1700W
- Compact, long-life digital brushless motor design
- Weight: 360 g
- Air flow rate 86,4 m³/hour
- 5 temperatures
- Cold air button
- 2 adjustable nozzles. Measurements: medium / large
- Extra flexible 3m cable
- Safety thermostat
- Stainless-steel filter
- Low noise level: 80 Db
- Voltage 220-240V ~
- Frequency: 50Hz
- Ergonomic design
- Robust and lightweight polycarbonate housing
- Ion generator, which softens and hydrates the hair, reducing drying times
- Diffuser for curly hair
- The device has a safety device, which triggers in case of malfunction
- Suitable for any type of natural hair

Secador CALIMA

CALIMA hair dryer

u.m.vta: 1  12 

REF. 07171/70

REF. 07171/50



Más
información
More
information

SCAN
ME!

Triple tecnología
(Iónico, cerámica y turmalina)

Triple technology
(Ionic, ceramic and tourmaline)





- Potencia: 2300W
- Motor profesional AC
- Peso: 530 g
- Caudal de aire 98 m³/h
- 2 velocidades, 3 temperaturas
- Botón de aire frío
- 2 boquillas orientables 62 y 70 mm
- Filtro extraíble de acero inoxidable
- Termostato de seguridad
- Cable con anilla para colgar
- Bajo nivel sonoro: 80 Db
- Voltaje 220-240V~
- Frecuencia: 50/60 Hz
- Súper compacto
- Iónico, cerámico y turmalina
- Compatible con difusor: 04346/50

- Power: 2300W
- Professional AC Motor
- Weight: 530 g
- Air flow rate 98 m³/hour
- 2 speeds, 3 temperatures
- Cold air button
- 2 adjustable nozzles 62 and 70 mm
- Removable stainless-steel filter
- Safety thermostat
- Cable with ring for hanging
- Low noise level: 80 Db
- Voltage 220-240V ~
- Frequency: 50/60 Hz
- Very compact
- Ionic, ceramic and tourmaline
- Compatible with 04346/50 diffuser



Secador **FURIOUS COMPACT PLUS**

FURIOUS COMPACT PLUS hair dryer

u.m.vta: 1  12 

REF. 06474



**Más información
sobre el secador
FURIOUS COMPACT PLUS**
More information about
FURIOUS COMPACT PLUS
hair dryer

SCAN
ME!



Los secadores Eurostil Furious and Furious Plus son una gama de secadores de potencia 2200W ideales para cualquier profesional que busque un secador versátil y que cumpla las expectativas más exigentes.



- Potencia: 2200W
- Motor compacto de larga duración AC
- Peso: 494 g
- Caudal de aire: 84 m³/hora
- 2 velocidades, 3 temperaturas
- Botón de aire frío
- 2 boquillas
- Filtro extraíble
- Termostato de seguridad
- Cable con anilla para colgar
- Voltaje 220-240V~
- Frecuencia: 50/60 Hz
- Embellecedor lila
- Compatible con difusor 04346/50 - 01147

The Eurostil Furious and Furious Plus hair dryers are a range of 2200W power dryers ideal for any professional looking for a versatile dryer that meets the most demanding expectations.

- Power: 2200W
- AC long-life compact motor
- Weight: 494 g
- Air flow: 84 m³ / hour
- 2 speeds, 3 temperatures
- Fixed cold air button
- 2 nozzles
- Removable filter
- Safety thermostat
- Cable with ring for hanging
- Voltage 220-240V ~
- Frequency: 50/60 Hz
- Violet embellishment
- Compatible with 04346/50 - 01147 diffuser

Secador FURIOUS

FURIOUS hair dryer

u.m.vta: 1  12 

REF. 04922



**Más información
sobre el secador FURIOUS**
More information about
FURIOUS hair dryer

SCAN
ME!

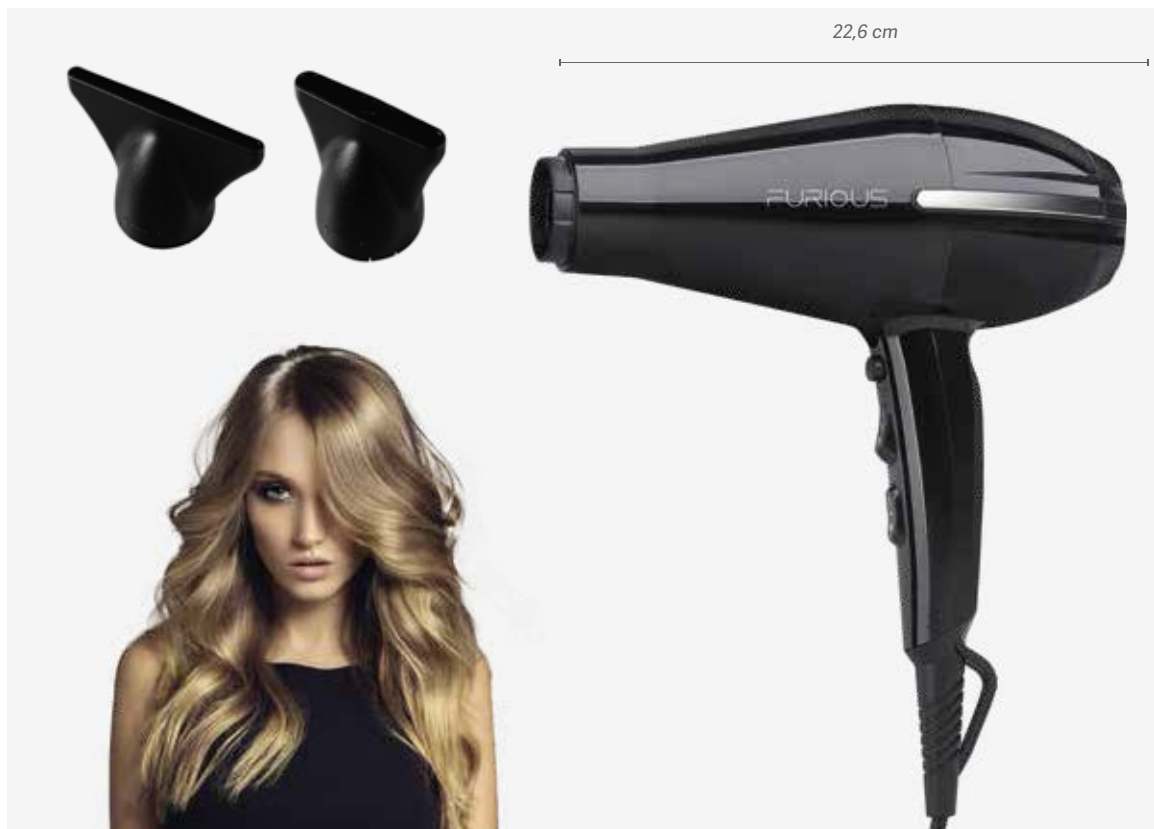



- Potencia: 2200W
- Motor compacto de larga duración AC
- Peso: 590 g
- Caudal de aire: 74 m³/hora
- 2 velocidades, 3 temperaturas
- Botón de aire frío
- 2 boquillas: 1 ancha, 1 estrecha
- Filtro extraíble
- Termostato de seguridad
- Cable con anilla para colgar
- Voltaje 220-240V~
- Frecuencia: 60 Hz
- Embellecedor plateado
- Compatible con difusor 04346/50 - 01147

- Power: 2200W
- AC long-life compact motor
- Weight: 590 g
- Air flow: 74 m³ / hour
- 2 speeds, 3 temperatures
- Fixed cold air button
- 2 nozzles: 1 wide, 1 narrow
- Removable filter
- Safety thermostat
- Cable with ring for hanging
- Voltage 220-240V ~
- Frequency: 60 Hz
- Silver embellishment
- Compatible with 04346/50 - 01147 diffuser

Secador ZONDA

ZONDA hair dryer

u.m.vta: 1  6 

REF. 04993/53 REF. 04993/70



Triple tecnología
(Iónico, cerámica y turmalina)

Triple technology
(Ionic, ceramic and tourmaline)



Los secadores Eurostil equipados con la TRIPLE TECNOLOGÍA (iónico, cerámica y turmalina) son una herramienta indispensable para los profesionales. Proporcionan hidratación, suavidad y brillo, secan más rápido, tienen efecto bactericida y reducen el envejecimiento de la fibra capilar. Permiten crear cualquier tipo de peinado: alisados, ondulados, volumen, et.

- Potencia: 2400W
- Motor compacto de larga duración AC
- Peso: 590 g
- Caudal de aire: 97 m³/hora
- 2 velocidades, 3 temperaturas
- Botón de aire frío fijo
- 2 boquillas orientables de 62mm y 70mm
- Filtro extraíble
- Termostato de seguridad
- Cable flexible 3m con anilla para colgar
- Bajo nivel sonoro
- Voltaje 220-240V~
- Frecuencia: 50/60 Hz
- Filtro acero inoxidable
- Iónico, cerámico y turmalina
- Compatible con difusor 04346/50 - 01147 - 03036/50

The Eurostil hair dryers equipped with the TRIPLE TECHNOLOGY (ionic, ceramic and tourmaline) are indispensable tool for professionals. They provide hydration, softness and shine, dry faster, have a bactericidal effect and reduce the aging of the hair fiber. They allow to create any type of hairstyle: smoothed, wavy, volume, etc.

- Power: 2400W
- AC long-life compact motor
- Weight: 590 g
- Air flow: 97 m³/hour
- 2 speeds, 3 temperatures
- Fixed cold air button
- 2 adjustable nozzles 62mm y 70mm
- Removable filter
- Safety thermostat
- Extra flexible 3m cable with ring for hanging
- Low sound level
- Voltage 220-240V~
- Frequency: 50/60 Hz
- Stainless steel filter
- Ionic, ceramic and tourmaline
- Compatible with 04346/50 - 01147 - 03036/50 diffuser



*¿Quieres
saber más?
Do you want
to know more?*



**SCAN
ME!**

23,6 cm



Secador WIND

WIND hair dryer

u.m.vta: 1  6 

REF. 04994/50

REF. 04994/59

Triple tecnología
(Iónico, cerámica y turmalina)

Triple technology
(Ionic, ceramic and tourmaline)



Los secadores Wind de Eurostil equipados con la TRIPLE TECNOLOGÍA (iónico, cerámica y turmalina) son unas herramientas indispensables para los profesionales. Proporcionan hidratación, suavidad y brillo, secan más rápido, tienen efecto bactericida y reducen el envejecimiento de la fibra capilar. Permiten crear cualquier tipo de peinado: alisados, ondulados, volumen, etc.

- Potencia: 2300W
- Motor compacto de larga duración AC
- Peso: 530 g
- Caudal de aire: 88 m³/hora
- 2 velocidades, 3 temperaturas
- Botón de aire frío
- 2 boquillas orientables de 62mm y 70mm
- Filtro extraíble
- Termostato de seguridad
- Cable flexible 3m con anilla para colgar
- Bajo nivel sonoro
- Voltaje 220-240V~
- Frecuencia: 50/60 Hz
- Con luz indicadora de temperatura
- Filtro acero inoxidable
- Compatible con difusor 04346/50 - 01147 - 03036/50

The Wind dryers by Eurostil equipped with the TRIPLE TECHNOLOGY (ionic, ceramic and tourmaline) are indispensable tools for professionals. They provide hydration, softness and shine, dry faster, have a bactericidal effect and reduce the aging of the hair fiber. They allow to create any type of hairstyle: smoothed, wavy, volume, etc.

- Power: 2300W
- AC long-life compact motor
- Weight: 530 g
- Air flow: 88 m³/hour
- 2 speeds, 3 temperatures
- Cold air button
- 2 adjustable nozzles 62mm and 70mm
- Removable filter
- Safety thermostat
- Extra flexible 3m cable with ring for hanging
- Low sound level
- Voltage 220-240V ~
- Frequency: 50/60 Hz
- With temperature indicator light
- Stainless steel filter
- Compatible with 04346/50 - 01147 - 03036/50 diffuser



**Más información
sobre el secador WIND**
More information
about WIND hair dryer



SCAN
ME!

19,5 cm



Secador COMPACT PROFESSIONAL

COMPACT PROFESSIONAL hair dryer

u.m.vta: 1  6 

REF. 04202



¿Quieres
saber más?
Do you want
to know more?

SCAN
ME!

*Motor potente
con generador de iones*

*Powerful engine
with ion generator*



El secador Compact profesional tiene un diseño atractivo, ergonómico y ligero. Disponible en negro, blanco y blanco con gomas de colores. Motor potente con generador de iones. Incluye dos boquillas de diferentes medidas.

- Potencia: 2000W
- Motor compacto de larga duración AC
- Peso: 580 g
- Caudal de aire: 90 m³/hora
- 2 velocidades, 3 temperaturas
- Botón de aire frío
- 2 boquillas orientables de 62mm y 70mm
- Filtro extraíble
- Termostato de seguridad
- Cable flexible 3m con anilla para colgar
- Bajo nivel sonoro
- Voltaje 220-240V~
- Frecuencia: 50/60 Hz
- Diseño ergonómico
- Carcasa robusta y ligera en poliamida
- Embellecedor de goma antideslizante
- Motor generador de iones
- Compatible con difusor 04346/50 - 01147 - 03036/50



The Compact Professional hair dryer has an attractive, ergonomic and lightweight design. It is available in black, white and white with coloured rubber fittings. It has a powerful engine with ion generator. It includes two nozzles of different sizes.



- Power: 2000W
- AC long-life compact motor
- Weight: 580 g
- Air flow: 90m³/ hour
- 2 speeds, 3 temperatures
- Cold air button
- 2 adjustable nozzles 62mm and 70mm
- Removable filter
- Safety thermostat
- Extra flexible 3m cable with ring for hanging
- Low sound level
- Voltage 220-240V ~
- Frequency: 50/60 Hz
- Ergonomic design
- Sturdy and lightweight polyamide frame
- Anti-slip rubber embellishment
- Engine with ion generator
- Compatible with 04346/50 - 01147 - 03036/50 diffuser

Secador COMPACT EXTRA LIGHT

COMPACT EXTRA LIGHT hair dryer

COMPACT
extra light

u.m.vta: 1  6 

u.m.vta: 1  12 



REF. 04203



REF. 04203/58



REF. 04203/58/99



El secador Compact Extra Light tiene un diseño atractivo, ergonómico y ligero. Disponible en negro, blanco y blanco con gomitas de colores. Motor potente con generador de iones. Incluye dos boquillas de diferentes medidas.



- Potencia: 1800W
- Motor DC
- Peso: 430 g
- Caudal de aire: 76 m³/hora
- 2 velocidades, 3 temperaturas
- Botón de aire frío
- 2 boquillas orientables de 62mm y 70mm
- Filtro extraíble
- Termostato de seguridad
- Cable flexible 3m con anilla para colgar
- Muy bajo nivel sonoro
- Voltaje 220-240V~
- Frecuencia: 50/60 Hz
- Compacto y MÁS LIGERO
- Embellecedor de goma antideslizante
- Motor con generador de iones
- Compatible con difusor 04346/50 - 01147 - 03036/50

The Compact Extra Light hair dryer has an attractive, ergonomic and lightweight design. It is available in black, white and white with coloured rubber fittings. It has a powerful engine with an ion generator. It includes two nozzles of different sizes.

- Power: 1800W
- DC motor
- Weight: 430 g
- Air flow: 76 m³/hour
- 2 speeds, 3 temperatures
- Cold air button
- 2 adjustable nozzles 62mm and 70mm
- Removable filter
- Safety thermostat
- Extra flexible 3m cable with ring for hanging
- Low sound level
- Voltage 220-240V ~
- Frequency: 50/60 Hz
- Compact and LIGHTER
- Anti-slip rubber embellishment
- Engine with ion generator
- Compatible with 04346/50 - 01147 - 03036/50 diffuser

Secador NEO 3800

NEO 3800 hair dryer

u.m.vta: 1  12 

NEO3800
PROFESIONAL

REF. 03323





- Potencia: 2000W
- Motor compacto de larga duración AC
- Peso: 590 g
- Caudal de aire: 84 m³/hora
- 2 velocidades, 3 temperaturas
- Botón de aire frío
- 2 boquillas orientables 63 mm y 72 mm
- Filtro extraíble
- Termostato de seguridad
- Cable flexible 3m con anilla para colgar
- Voltaje 220-240V~
- Frecuencia: 50/60 Hz
- Protección térmica
- Compatible con difusor: 04346/50 - 01147 - 03036/50

- Power: 2000W
- AC long-life compact motor
- Weight: 590 g
- Air flow: 84 m³/hour
- 2 speeds, 3 temperatures
- Cold air button
- 2 adjustable nozzles 63 mm and 72 mm
- Removable filter
- Safety thermostat
- Extra flexible 3m cable with ring for hanging
- Voltage 220-240V ~
- Frequency: 50/60 Hz
- Thermal insulation
- Compatible with: 04346/50 - 01147 - 03036/50 diffuser

Secador NEO 3830

NEO 3830 hair dryer

u.m.vta: 1  12 

ionic **NEO3830**
PROFESIONAL

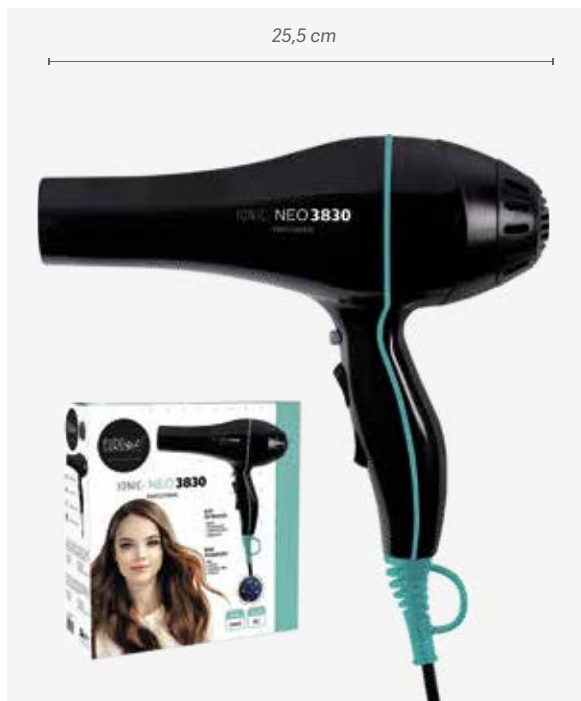

REF. 03904



- Potencia: 2000W
- Motor compacto de larga duración AC
- Peso: 820 g
- Caudal de aire: 82 m³/hora
- 2 velocidades, 3 temperaturas
- Botón de aire frío
- 2 boquillas orientables 63 mm y 72mm
- Filtro extraíble
- Termostato de seguridad
- Cable flexible 3m con anilla para colgar
- Voltaje 220-240V~
- Frecuencia: 50/60 Hz
- Turmalina e iónico
- Protección térmica
- Compatible con difusor: 04346/50 - 01147 - 03036/50

- Power: 2000W
- AC long-life compact motor
- Weight: 820 g
- Air flow: 82 m³/hour
- 2 speeds, 3 temperatures
- Cold air button
- 2 adjustable nozzles 63 mm and 72 mm
- Removable filter
- Safety thermostat
- Extra flexible 3m cable with ring for hanging
- Voltage 220-240V ~
- Frequency: 50/60 Hz
- Tourmaline and ionic
- Thermal insulation
- Compatible with: 04346/50 - 01147 - 03036/50 diffuser

Secador NEO 3840 NEO 3840 hair dryer

u.m.vta: 1  12 

REF. 04363



SCAN
ME!

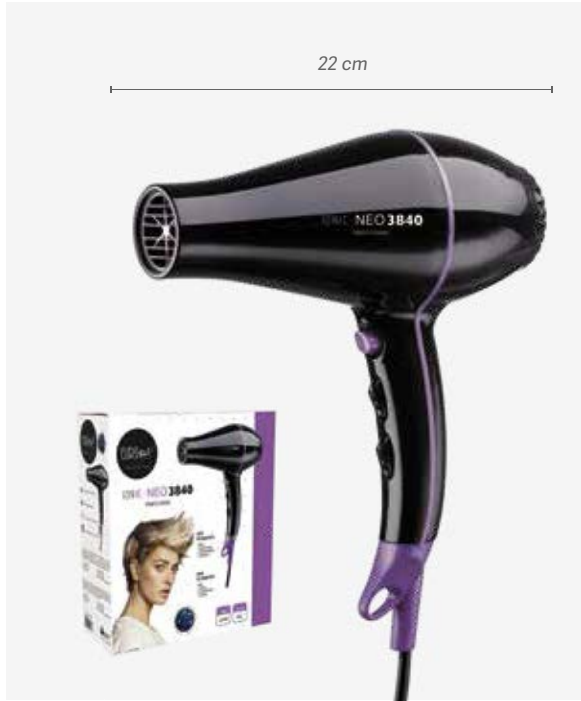

ionic NEO 3840
PROFESIONAL



- Potencia: 2200W
- Motor compacto de larga duración AC - 70Db
- Peso: 813 g
- Caudal de aire: 70 m³/hora
- 2 velocidades, 5 temperaturas
- Botón de aire frío
- 2 boquillas orientables: 1 ancha, 1 estrecha
- Filtro extraíble de acero inoxidable
- Termostato de seguridad
- Cable flexible 3m con anilla para colgar
- Voltaje 220-240V~
- Frecuencia: 50/60 Hz
- Diseño ergonómico
- Carcasa robusta y ligera en poliamida
- Turmalina e iónico
- Compatible con difusor: 04346/50 - 01147 - 03036/50

- Power: 2200W
- AC long-life compact motor - 70 Db
- Weight: 813 g
- Air flow: 70 m³/hour
- 2 speeds, 5 temperatures
- Cold air button
- 2 adjustable nozzles: 1 wide, 1 narrow
- Removable stainless steel filter
- Safety thermostat
- Extra flexible 3m cable with ring for hanging
- Voltage 220-240V ~
- Frequency: 50/60 Hz
- Ergonomic design
- Sturdy and lightweight polyamide frame
- Tourmaline and ionic
- Compatible with: 04346/50 - 01147 - 03036/50 diffuser

Secador NEO 3820 NEO 3820 hair dryer

u.m.vta: 1  12 

REF. 03905

ionic NEO 3820
PROFESIONAL

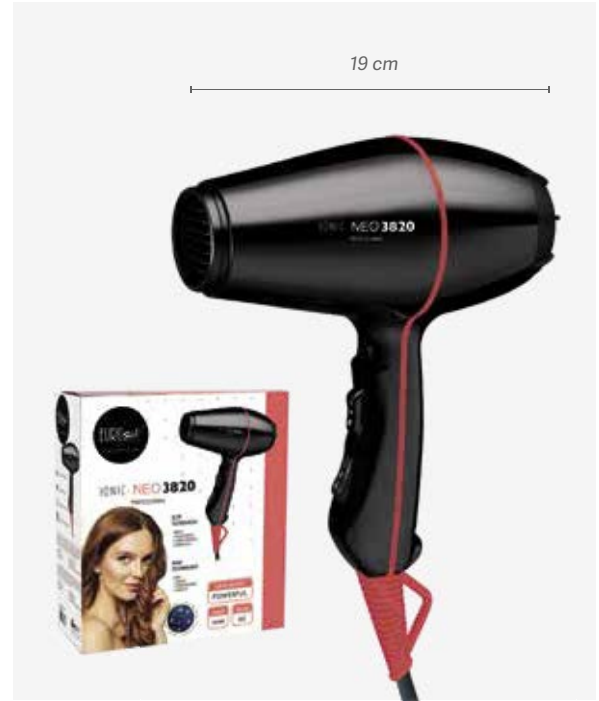



- Potencia: 2000W
- Motor compacto de larga duración AC
- Peso: 840 g
- Caudal de aire: 79 m³/hora
- 2 velocidades, 3 temperaturas
- Botón de aire frío
- 2 boquillas: 1 ancha, 1 estrecha
- Filtro extraíble
- Termostato de seguridad
- Cable flexible 3m con anilla para colgar
- Voltaje 220-240V~
- Frecuencia: 50/60 Hz
- Turmalina e iónico
- 1 difusor

- Power: 2000W
- AC long-life compact motor
- Weight: 840 g
- Air flow: 79 m³/hour
- 2 speeds, 3 temperatures
- Cold air button
- 2 nozzles: 1 wide, 1 narrow
- Removable filter
- Safety thermostat
- Extra flexible 3m cable with ring for hanging
- Voltage 220-240V ~
- Frequency: 50/60 Hz
- Tourmaline and ionic
- 1 diffuser

Secador TRAMUNTANA

TRAMUNTANA hair dryer



u.m.vta: 1	 6	
------------	---	---

 REF. 04264/62

 REF. 04264/64

 REF. 04264/68

 REF. 04264/75



El Secador Tramuntana tiene un diseño atractivo, ergonómico y ligero. Disponible en negro y 4 colores muy actuales y frescos. Incluye dos boquillas de diferentes medidas y un difusor para el cabello rizado.

- Potencia: 2000W
- Motor compacto de larga duración AC
- Peso: 500 g
- Caudal de aire: 70 m³/hora
- 2 velocidades, 3 temperaturas
- Botón de aire frío
- 2 boquillas: 1 ancha, 1 estrecha
- Filtro extraíble
- Termostato de seguridad
- Cable 3m con anilla para colgar
- Voltaje 220-240V~
- Frecuencia: 50/60 Hz
- Botones laterales
- 1 difusor
- Compatible con difusor 04346/50
- Nivel sonoro 70Db



Tramuntana hair dryer has an attractive, light and ergonomic design. Available in black plus 4 very modern and fresh colours. Includes two different-sized nozzles and a diffuser for curly hair.

- Power: 2000W
- AC long-life compact motor
- Weight: 500 g
- Air flow: 70 m³/hour
- 2 speeds, 3 temperatures
- Cold air button
- 2 nozzles: 1 wide, 1 narrow
- Removable filter
- Safety thermostat
- 3m Cable with ring for hanging
- Voltage 220-240V ~
- Frequency: 50/60 Hz
- Side buttons
- 1 diffuser
- Compatible with 04346/50 diffuser
- Sound level 70Db

Secador MEDITERRÁNEO

MEDITERRÁNEO hair dryer

MEDITERRÁNEO

u.m.vta: 1  6 

REF. 04263/50



REF. 04263/64



REF. 04263/68



REF. 04263/75



El Secador Mediterráneo tiene un diseño atractivo, ergonómico y ligero. Disponible en negro y 4 colores muy actuales y frescos. Incluye dos boquillas de diferentes medidas y un difusor para el cabello rizado.

- Potencia: 2000W
- Motor compacto de larga duración AC
- Peso: 500 g
- Caudal de aire: 70 m³/hora
- 2 velocidades, 3 temperaturas
- Botón de aire frío
- 2 boquillas: 1 ancha, 1 estrecha
- Filtro extraíble
- Termostato de seguridad
- Cable con anilla para colgar
- Voltaje 220-240V~
- Frecuencia: 50/60 Hz
- 1 difusor
- Nivel sonoro 70Db

Mediterráneo hair dryer has an attractive, light and ergonomic design. Available in black plus 4 very modern and fresh colours. Includes two different-sized nozzles and a diffuser for curly hair.

- Power: 2000W
- AC long-life compact motor
- Weight: 500 g
- Air flow: 70 m³/hour
- 2 speeds, 3 temperatures
- Cold air button
- 2 nozzles: 1 wide, 1 narrow
- Removable filter
- Safety thermostat
- Cable with ring for hanging
- Voltage 220-240V ~
- Frequency: 50/60 Hz
- 1 diffuser
- Sound level 70Db

Secador **TURBO STRATOS 3800 ETI** TURBO STRATOS 3800 ETI hair dryer



u.m.vta: 1 12

REF.02931



- Potencia: 2400W
- Motor compacto de larga duración AC
- Peso: 590 g
- Caudal de aire: 99 m³/hora
- 2 velocidades, 3 temperaturas
- Botón de aire frío
- 2 boquillas: 1 ancha, 1 estrecha
- Filtro extraíble
- Termostato de seguridad
- Cable con anilla para colgar
- Nivel sonoro: 69 dB
- Voltaje 220-240V~
- Frecuencia: 50/60 Hz
- Compatible con difusores 04346/50 - 01147 - 03036/50

- Power: 2400W
- AC long-life compact motor
- Weight: 590 g
- Air flow: 99 m³/hour
- 2 speeds, 3 temperatures
- Cold air button
- 2 nozzles: 1 wide, 1 narrow
- Removable filter
- Safety thermostat
- Cable with ring for hanging
- Sound level: 69 dB
- Voltage 220-240V ~
- Frequency: 50/60 Hz
- Compatible with 04346/50 - 01147 - 03036/50 diffusers

Secador **NANO STRATOS 3700 ETI** NANO STRATOS 3700 ETI hair dryer



u.m.vta: 1 12

REF. 03003/50



- Potencia: 2200W
- Motor profesional de larga duración AC
- Peso: 575 g
- Caudal de aire: 100 m³/hora
- 2 velocidades, 3 temperaturas
- Botón de aire frío
- 2 boquillas
- Filtro extraíble
- Termostato de seguridad
- Cable con anilla para colgar
- Nivel sonoro: bajo
- Voltaje 220-240V~
- Frecuencia: 50/60 Hz
- Excelente tecnología
- Compatible con difusores 04346/50 - 01147 - 03036/50

- Power: 2200W
- AC long-life compact motor
- Weight: 575 g
- Air flow: 100 m³/hour
- 2 speeds, 3 temperatures
- Cold air button
- 2 nozzles
- Removable filter
- Safety thermostat
- Cable with ring for hanging
- Sound level: low
- Voltage 220-240V ~
- Frequency: 50/60 Hz
- Excellent technology
- Compatible with 04346/50 - 01147 - 03036/50 diffusers

Porta secador
Hair dryer holder

u.m.vta: 1  1



REF.04431



Porta secador de pie metálico, apto para secadores de boca grande. Fácil de manejar y trasladar, cómodo por su estabilidad. Diseño elegante y moderno.

Hair dryer holder with metallic stand, with large hole for all size of dryers. Easy to handle and carry, comfortable for stability. Elegant and modern design.

Porta secador pared metálico
Metal wall hair dryer holder

u.m.vta: 1  12 



REF.07275

- Material: aluminio
- Con embellecedor de goma



- Material: aluminum
- With rubber trim



Porta secador adaptable
Adaptable hair dryer holder

u.m.vta: 1  16 

REF. 00672



u.m.vta: 1  6 

REF. 02830

- Metálico
- Metallic





Difusor universal
Universal diffuser

u.m.vta: 1  12 

    
REF. 01147 **REF. 01147/99**

Difusor universal
Universal diffuser



u.m.vta: 1  12 

    
REF. 03036/50 **REF. 03036/99**



Difusores plegables de SILICONA

SILICONE folding diffusers

u.m.vta: 1  8 



REF. 04346/62



REF. 04346/68



REF. 04346/64



REF. 04346/50



- Reparte el calor de forma homogénea
- Diseño especial, ligero, plegable y no ocupa espacio
- Universal, se adapta a la mayoría de los secadores
- Ref. 04346: Altura máx. 12,9 cm mín. 6,8 cm
- Ref. 04346: Ø 6,3 cm - Ø 13,9 cm

- Spreads heat homogeneously
- Special lightweight and foldable design that does not take up space
- Universal, adapts to most hair dryers
- Ref. 04346: Max. height: 12,9 cm min. height. 6,8 cm
- Ref. 04346: Ø 6,3 cm - Ø 13,9 cm



Difusor esponja

Sponge diffuser

u.m.vta: 1  12 

REF. 02371

Ideal para proporcionar calor a trabajos de mechas, coloración, permanentes y tratamientos capilares

Ideal for providing heat to wicks works, coloration, perms and hair treatments



Activador negro Black activator



u.m.vta: 1  1

REF.03008

Soporte pared
Wall bracket

- Potencia: 900W
- Termoestimulador de última generación
- Compacto, ocupa poco sitio
- Actúa mediante calor para que la coloración penetre en poco tiempo
- Con temporizador, regulador electrónico de la radiación de energía
- 5 interruptores individuales para encender cada una de las lámparas
- Tipo resistencia: infrarrojos
- Temperatura máxima 40°C
- Frecuencia: 50Hz
- Voltaje 220-240V~

- Power: 900W
- Cutting-edge thermo stimulator
- Compact, takes up little space
- Uses heat to allow the colour to penetrate in little time
- Features a timer and an electronic energy radiation regulator
- 5 individual switches to turn on each one of the lamps individually
- Resistance type: infra-red
- Maximum temperature 40°C
- Frequency: 50 Hz
- Voltage 220-240V ~

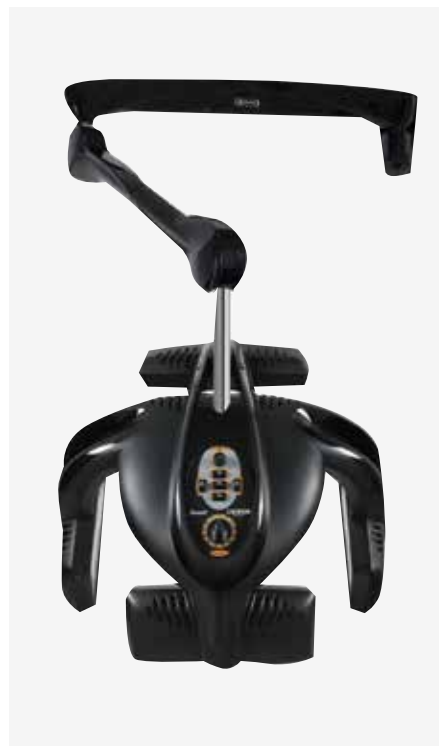

Activador blanco White activator

u.m.vta: 1  1

REF.04274

Soporte pared
Wall bracket

- Potencia: 1400W
- Termoestimulador de última generación compacto
- Dispone de ventilación
- Con temporizador, regulador electrónico de la radiación de la energía
- Pantalla digital
- Tensión: 220-240V~
- Material: nylon
- Tipo de resistencia: infrarrojos
- 3 velocidades

- Power: 1400W
- Compact, cutting-edge thermo stimulator
- Features ventilation openings
- Features a timer and an electronic energy radiation regulator
- Digital screen
- Tension: 220-240V~
- Material: nylon
- Resistance type: infra-red
- 3 speeds



Activador electrónico negro

Black electronic activator

u.m.vta: 1  1

Soporte pie
With stand

REF.07433

Soporte pared
With wall bracket

REF.07434



Activador compacto con diseño novedoso que ofrece la máxima comodidad para el cliente.

Características:

- Potencia: 900W
- Con temporizador
- Regulación electrónica de la irradiación de energía
- 5 interruptores individuales para encender y apagar cada una de las lámparas circulares e infrarrojo de cuarzo

Features:

- Power: 900W
- Timer
- Electronic regulation of energy radiation
- 5 individual switches to turn each circular lamp on and off and quartz infrared



Secador casco GONG "GONG" helmet hair dryer



u.m.vta: 1  1

Soporte pared
Wall bracket



REF. 03006



REF. 03006/58

- Potencia 1400W
- 1 velocidad
- Diseño moderno y ergonómico
- Secador muy rápido por el gran caudal de aire repartido de forma uniforme
- Altura de 210 cm para colocar en pared el brazo

- Power 1400W
- 1 speed
- Modern and ergonomic design
- The dryer is very fast due to the large volume of air distributed evenly
- Height of 210 cm to place the arm on the wall



Secador casco ATOMIC TURBO

ATOMIC TURBO helmet hair dryer

u.m.vta: 1	 1
------------	---

Soporte pie
Stand bracket

REF.07436

Casco profesional con temporizador, termostato, luz de control de temperatura y (si es aplicable) selector de velocidad.

- Diseño retro-futurista con visor integrado
- Mayor potencia - 1400W ULTRA POWER
- Campana con flujo de aire optimizado

Configuraciones:

- Automático / 1 velocidad
- 4 velocidades TURBO

Professional helmet dryer with timer, thermostat, temperature control light and speed dial

- Retro-futuristic design with integrated visor
- More power - 1400W ULTRA POWER
- Directional airflow hood

Configurations:

- Automatic / 1 speed
- 4 speed TURBO



Secador casco HOT WIND automático

HOT WIND automatic helmet hair dryer

u.m.vta: 1	 1
------------	---

Soporte pie
Stand bracket



REF. 04272/50

- Potencia: 1000W
- Voltaje: 220-240V~
- Frecuencia: 50/60Hz
- 1 velocidad
- Motor de 1300 rpm
- Material: acero
- Material casco: ABS

- Power: 1000W
- Voltage: 220-240V~
- Frequency: 50 / 60Hz
- 1 speed
- 1300 rpm engine
- Material: steel
- Material helmet: ABS



Vaporizador Ceriotti con pie Ceriotti vaporizer with stand

u.m.vta: 1  1Lila
Lilac

REF.04275/68

Plata
Silver

REF.04275/54

- Potencia: 1000W
- Campana con visera regulable nylon, policarbonato y acero
- Sin OZONO

- Power: 1000W
- Hood with a regulable nylon visor, made from polycarbonate and steel
- Without OZONE



Vaporizador Ceriotti GEYSER OZONO con pie GEYSER OZONO Ceriotti vaporizer with stand

u.m.vta: 1  1

REF.07435

Vaporizador profesional para tratamientos estéticos curativos. Al generar vapor, Geyser ayuda a la penetración de productos tricológicos en las cutículas, reduciendo drásticamente los tiempos de aplicación. La lámpara de ozono (en los modelos predispuestos) produce un efecto esterilizante que puede ayudar a mejorar la salud del cabello y la piel.

- Temporizador
- Regulador electrónico de temperatura y vapor
- Luz de funcionamiento
- Tanque de condensado
- Lámpara de ozono

Professional steamer for aesthetic and curative treatments. By generating steam, Geyser favours the absorption of hair products into the cuticles, considerably reducing exposure times. The ozone lamp (in adapted models) produces a sterilising effect that can improve hair and skin health.

- Timer
- Electronic temperature and steam quantity regulator
- Operation light
- Condensate tank
- Ozone lamp



Secador casco ORLA ORLA helmet hair dryer

u.m.vta: 1  1

Soporte pared
Wall bracket

REF.03314

Soporte pie
Stand bracket

REF.03313

- Potencia: 1175W
- Voltaje: 220-240V~
- Frecuencia: 50Hz
- 5 velocidades
- Temporizador 60 minutos máximo
- Temperatura 70°C máximo
- El equipo cuenta con un dispositivo de seguridad que se acciona automáticamente en caso de mal funcionamiento del aparato

- Power: 1175W
- Voltage: 220-240V~
- Frequency: 50Hz
- 5 speeds
- Timer 60 minutes maximum
- Temperature 70°C maximum
- The equipment has a safety device that switches on automatically in the event of a malfunction



Vaporizador Eurostil Eurostil vaporizer

u.m.vta: 1  1

Soporte pie
Stand bracket

REF.03315

Soporte pared
Wall bracket

REF.03316

- Potencia: 400W
- Sistema de precalentamiento
- Led indicativo de encendido
- Led luminoso y acústico, indicativo de falta de agua en el vaporizador
- Generador de ozono
- Temporizador
- Tanque interior para la condensación del agua (realización del vapor) con válvula de alivio y sistema para cualquier retorno
- SOLO se puede utilizar agua destilada

- Power: 400W
- Pre-heating system
- On / off LED indicator
- Acoustic and light indicators that indicate when water levels in the evaporator are low
- Ozone generator
- Timer
- Inside tank for water condensation (steam production) with a relief and system valve for return flows
- This device may ONLY be used with distilled water



Casco secador Valera
Valera helmet hair dryer

Valera 

u.m.vta: 1  6

REF. 04615

Casco secador con ionizador VALERA mod. Ionic Confort
 VALERA Helmet hair dryer with ionizer model ionic Confort



- Potencia: 600W
- Cable de 3m de largo
- Secador de capucha cómodo y ergonómico
- 2 velocidades y 3 temperaturas
- Interruptor aire frío
- Ultraligera, silenciosa y de tacto suave
- Práctica bolsa de viaje incluida
- Generador de iones
- Frecuencia: 50/60 Hz

- Power: 600W
- Cable 3 meters long
- Comfortable and ergonomic hood hair dryer
- 2 speeds and 3 temperature levels
- Cold air switch
- Ultra-light, silent, soft touch
- Practical travel case included
- Ion generator
- Frequency: 50/60 Hz



Plancha EASY

EASY hair straightener

u.m.vta: 1  6 

REF. 06332/68 REF. 06332/70



SCAN ME!





Placas de cerámica con turmalina que cuidan el cabello proporcionando brillo y suavidad. Su carga iónica previene que los cabellos se electricen y encrespen y con tecnología Nano Silver que elimina las bacterias. Función automática de auto desconexión: el aparato se desconectará de forma automática si no se utiliza pasados unos 60 minutos aproximadamente.

- Temperatura entre 100°C - 230°C
- Potencia: 44W
- Termostato de seguridad
- Metros de cable: 2,7 m de cable con rotación 360°

Tourmaline ceramic plates take care of the hair providing shine and softness. Its ionic charge prevents the hair from electrifying and frizzing and the Nano Silver technology eliminates bacteria. Auto switch-off function: the unit switches off automatically after approx. 60 minutes if not in use.

- Temperature: between 100°C and 230°C
- Power: 44W
- Safety thermostat
- Cable meters: 360° rotating and 2,7 m long

Plancha INFRARROJO cerámica y turmalina INFRA-RED ceramic and tourmaline hair straightener

u.m.vta: 1  6 

REF. 06331/68



¿Quieres
saber más?
Do you want
to know more?

SCAN
ME!



Placas de cerámica con turmalina que cuidan el cabello proporcionando brillo y suavidad. Su carga iónica previene que los cabellos se electricen y encrespen y con tecnología Nano Silver que elimina las bacterias. Función automática de auto desconexión: el aparato se desconectará de forma automática si no se utiliza pasados unos 60 minutos aproximadamente. Luz infrarroja que desintoxica y desinfecta el cabello y al mismo tiempo reduce la agresión del calor de las placas. Sus principales propiedades son la mejora de la circulación y estimulación del crecimiento del cabello.



- Temperatura entre 130°C - 230°C
- Potencia: 44W
- Termostato de seguridad
- Metros de cable: 2,7 m de cable con rotación 360°
- Calentamiento de placas: 20 segundos
- Resistencia MCH
- Pantalla LCD indicando temperatura
- Termostato interno que evita el sobrecalentamiento
- Mango "SOFT-TOUCH"
- Cerámica y turmalina

Tourmaline ceramic plates take care of the hair providing shine and softness. Its ionic charge prevents the hair from electrifying and frizzing and the Nano Silver technology eliminates bacteria. Auto switch-off function: the unit switches off automatically after approx. 60 minutes if not in use. The infra-red light detoxifies and disinfects the hair, and at the same time, reduces the heat aggression of the plates. Its main properties are improve circulation and the stimulation of hair growth.

- Temperature: between 130°C and 230°C
- Power: 44W
- Safety thermostat
- Cable meters: 360° rotating and 2,7 m long
- The plate heats 20 seconds
- MCH resistance
- LCD indicating the temperature
- Internal thermostat to prevent overheating
- "SOFT-TOUCH" handle
- Ceramic and tourmaline

Plancha profesional FRIZZE

FRIZZ professional hair straightener

u.m.vta: 1  6 

REF. 06163/68



¿Quieres
saber más?
Do you want
to know more?

SCAN
ME!

Luz que al llegar a la temperatura deseada quedará fija

Light that will be fixed when the desired temperature is reached





Placas de turmalina que cuidan el cabello proporcionando brillo y suavidad. Su carga iónica previene que los cabellos se electricen y encrepen y con tecnología Nano Silver que elimina las bacterias.

- Temperatura: entre 130°C y 230°C
- Potencia: 65W
- Termostato de seguridad
- Metros de cable: 3 m de cable con rotación 360°
- Voltaje: 110 - 240 V~
- Frecuencia: 50/60 Hz
- Desconexión automática después de 60 minutos
- Resistencia: calentamiento ultra rápido con resistencia PTC
- Ajuste temperatura mediante dial
- Control por microprocesador
- Acabado soft touch
- Luz indicadora de temperatura
- Cerámica y turmalina
- 3 placas intercambiables
- Para cabello natural
- NO UTILIZAR PARA CABELLO SINTÉTICO O MOJADO

Tourmaline plates which take care of your hair providing shine and softness. Thanks to their ionic charge, they prevent hair from frizzing and with Nano silver technology that eliminates bacteria.

- Temperature: between 130°C and 230°C
- Power: 65W
- Safety thermostat
- Cable meters: rubber cable 360° rotating and 3 m long
- Voltage: 110 - 240 V~
- Frequency: 50/60 Hz
- Auto-shut-off after 60 minutes
- Resistance: PTC heating element for an ultra fast heating
- Adjust temperature by dial
- Microprocessor control
- Soft touch handle
- Temperature indicator light
- Ceramic and tourmaline
- 3 interchangeable plates
- To be used only on natural human hair
- DO NOT USE FOR SYNTHETIC OR WET HAIR

Plancha profesional CERÁMICA Y TURMALINA CERAMIC AND TOURMALINE professional hair straightener

u.m.vta: 1  6 



REF. 06173/50



REF. 06173/53



REF. 06173/70



¿Quieres
saber más?
Do you want
to know more?

SCAN
ME!



Placas de cerámica con turmalina que cuidan el cabello proporcionando brillo y suavidad. Su carga iónica previene que los cabellos se electricen y encrespen y con tecnología Nano Silver que elimina las bacterias.



- Temperatura: entre 80°C y 230°C
- Potencia: 43W
- Termostato interno que evita el sobrecalentamiento
- Metros de cable: 3 m de cable con rotación 360°
- Voltaje: 110 - 240 V~
- Frecuencia: 50/60 Hz
- Pantalla LCD indicando temperatura
- Desconexión automática después de 60 minutos
- Resistencia: calentamiento de las placas en tan solo 20 segundos, con resistencia MCH
- Ajuste temperatura mediante botones
- Mango soft touch
- Memoria de temperatura
- Para cabello natural
- NO UTILIZAR PARA CABELLO SINTÉTICO O MOJADO

Ceramic plates with tourmaline that care hair providing shine and smoothness. Its ionic charge prevents hair from being electrified and curled and the Nano Silver technology eliminates bacteria.

- Temperature: between 80°C and 230°C
- Power: 43W
- Internal thermostat that prevents overheating
- Cable meters: 360° rotating and 3 m long
- Voltage: 110 - 240 V~
- Frequency: 50/60 Hz
- LCD screen indicating temperature
- Auto-shut-off after 60 minutes
- Resistance: heating of plates in just 20 seconds, with MCH resistance
- Adjust temperature by buttons
- Soft touch handle
- Temperature memory
- To be used only on natural human hair
- DO NOT USE FOR SYNTHETIC OR WET HAIR

Plancha profesional TITANIO

TITANIUM professional hair straightener

u.m.vta: 1  6 



REF. 06174/50



REF. 06174/70

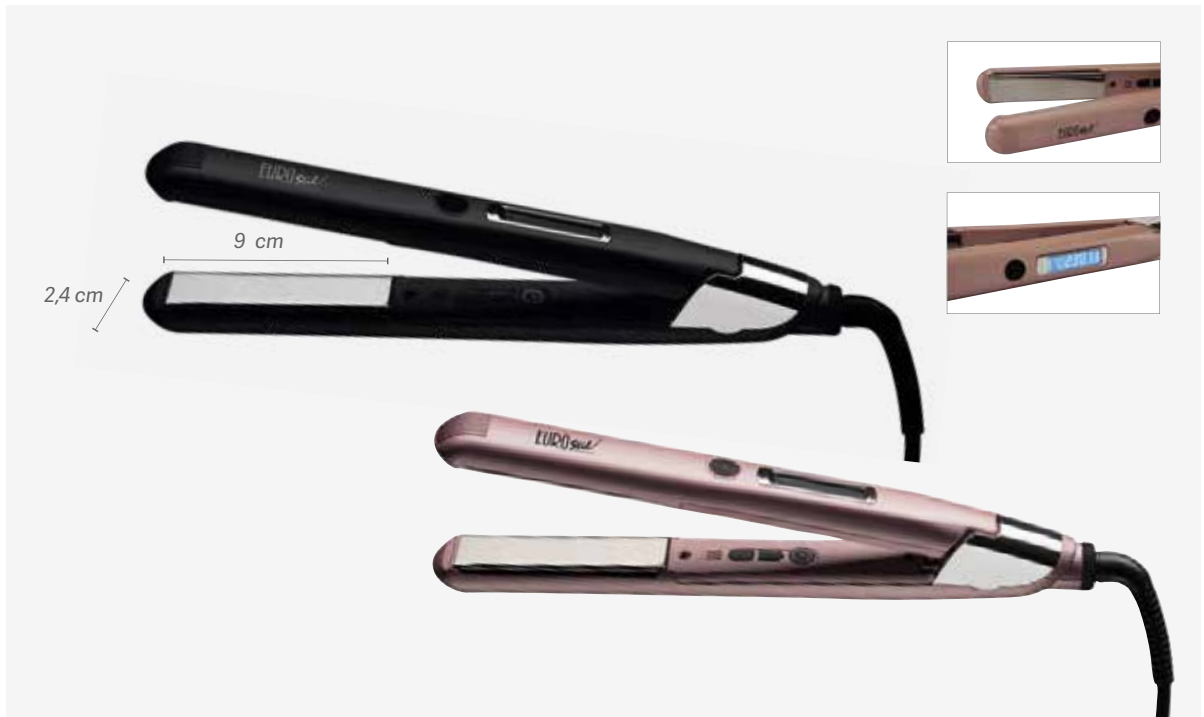

Placas de titanio que cuidan el cabello proporcionándole brillo y suavidad y con tecnología Nano Silver que elimina las bacterias.



- Temperatura: entre 80°C y 230°C
- Potencia: 38W
- Termostato interno que evita el sobrecalentamiento
- Metros de cable: 3 m de cable con rotación 360°
- Voltaje: 110 - 240 V~
- Frecuencia: 50/60 Hz
- Pantalla LCD indicando temperatura
- Desconexión automática después de 60 minutos
- Resistencia: calentamiento de las placas en tan solo 20 segundos, con resistencia MCH
- Ajuste temperatura mediante botones
- Mango soft touch
- Memoria de temperatura
- Cerámica y turmalina
- Para cabello natural
- NO UTILIZAR PARA CABELLO SINTÉTICO O MOJADO

Titanium plates that care hair providing shine and smoothness and the Nano Silver technology eliminates bacteria.

- Temperature: between 80°C and 230°C
- Power: 38W
- Internal thermostat that prevents overheating
- Cable meters: 360° rotating and 3 m long
- Voltage: 110 - 240 V~
- Frequency: 50/60 Hz
- LCD screen indicating temperature
- Auto-shut-off after 60 minutes
- Resistance: heating of plates in just 20 seconds, with MCH resistance
- Adjust temperature by buttons
- Soft touch handle
- Temperature memory
- Ceramic and tourmaline
- To be used only on natural human hair
- DO NOT USE FOR SYNTHETIC OR WET HAIR

Plancha profesional ADVANCE

ADVANCE professional hair straightener

u.m.vta: 1  6 

 REF. 06139/50  REF. 06139/70



¿Quieres
saber más?
Want
know more?

SCAN
ME!



Placas de cerámica que cuidan el cabello proporcionándole brillo y suavidad y con tecnología Nano Silver que elimina las bacterias.

- Temperatura: entre 130°C y 230°C
- Potencia: 50W
- Termostato interno que evita el sobrecalentamiento
- Metros de cable: 2,7 m de cable con rotación 360°
- Voltaje: 110 - 240 V~
- Frecuencia: 50/60 Hz
- Pantalla LCD indicando temperatura
- Desconexión automática después de 60 minutos
- Resistencia: calentamiento de las placas en tan solo 20 segundos, con resistencia MCH
- Ajuste temperatura mediante botones
- Mango soft touch
- Para cabello natural
- NO UTILIZAR PARA CABELLO SINTÉTICO O MOJADO

Ceramic plates that care hair providing shine and smoothness and the Nano Silver technology eliminates bacteria.

- Temperature: between 130°C and 230°C
- Power: 50W
- Internal thermostat that prevents overheating
- Cable meters: 360° rotating and 2,7 m long
- Voltage: 110 - 240 V~
- Frequency: 50/60 Hz
- LCD display indicating temperature
- Auto-shut-off after 60 minutes
- Resistance: heating of plates in just 20 seconds, with MCH resistance
- Adjust temperature by buttons
- Soft touch handle
- To be used only on natural human hair
- DO NOT USE FOR SYNTHETIC OR WET HAIR

Plancha profesional IONIC

IONIC professional hair straightener

u.m.vta: 1  6 



REF. 06138/50



REF. 06138/59



REF. 06138/53



¿Quieres
saber más?
Do you want
to know more?

SCAN
ME!



Placas de cerámica que cuidan el cabello proporcionándole brillo y suavidad y con tecnología Nano Silver que elimina las bacterias.

- Temperatura: entre 130°C y 230°C
- Potencia: 44W
- Termostato interno que evita el sobrecalentamiento
- Metros de cable: 2,7 m de cable con rotación 360°
- Voltaje: 110 - 240 V~
- Frecuencia: 50/60 Hz
- Pantalla LED indicando temperatura
- Desconexión automática después de 60 minutos
- Resistencia: calentamiento de las placas en tan solo 20 segundos, con resistencia MCH
- Ajuste temperatura mediante botones
- Mango soft touch
- Generadora de iones, que suaviza e hidrata el cabello, reduciendo el tiempo de secado.
- Sistema de cierre de placas mediante palanca
- Cerámica y turmalina
- Para cabello natural
- NO UTILIZAR PARA CABELLO SINTÉTICO O MOJADO

Ceramic plates that care hair providing shine and smoothness and the Nano Silver technology eliminates bacteria.

- Temperature: between 130°C and 230°C
- Power: 44W
- Internal thermostat that prevents overheating
- Cable meters: 360° rotating and 2,7 m long
- Voltage: 110 - 240 V~
- Frequency: 50/60 Hz
- LED display indicating temperature
- Auto-shut-off after 60 minutes
- Resistance: heating of plates in just 20 seconds, with MCH resistance
- Adjust temperature by buttons
- Soft touch handle
- Ion generator, which softens and moisturizes hair, reducing drying time
- Plate closing system by lever
- Ceramic and tourmaline
- To be used only on natural human hair
- DO NOT USE FOR SYNTHETIC OR WET HAIR

Plancha cerámica PLATINIUM

PLATINIUM ceramic hair straightener

u.m.vta: 1  3

REF. 06145

Placas platina
con placas de cerámica y
turmalina basculantes

Platinum plates
with tilting ceramic and
tourmaline plates





- Temperatura: entre 150°C y 230°C
- Potencia: 48W
- Metros de cable: 2,7 m de cable con rotación 360°
- Voltaje: 220 - 240 V~
- Frecuencia: 50/60 Hz
- Desconexión automática después de 60 minutos
- Resistencia: calentamiento de las placas en tan solo 20 segundos, con resistencia MCH
- Ajuste temperatura mediante dial
- Sistema de cierre de placas mediante palanca
- Generador de iones
- NO UTILIZAR PARA CABELLO SINTÉTICO O MOJADO

- Temperature: between 150°C and 230°C
- Power: 48W
- Cable meters: 360° rotating and 2,7 m long
- Voltage: 220 - 240 V~
- Frequency: 50/60 Hz
- Auto-shut-off after 60 minutes
- Resistance: heating of plates in just 20 seconds, with MCH resistance
- Adjust temperature by dial
- Plate closing system by lever
- Ion generator
- DO NOT USE FOR SYNTHETIC OR WET HAIR

Mini plancha placas cerámica basculantes

Mini hair straightener with tilting ceramic plates

u.m.vta: 1  20 



REF. 06568/50



REF. 06568/70



Placas de cerámica con turmalina que cuidan el cabello proporcionando brillo y suavidad.

- Temperatura máxima 200°C
- Potencia: 22W
- Termostato de seguridad
- Cable de goma de 2m de largo
- Voltaje: 100-240V~
- Frecuencia: 50/60 Hz
- Calentamiento de placas en tan sólo 30 segundos
- Resistencia PTC que evita el sobrecalentamiento
- Apta para cualquier tipo de cabello natural
- NO UTILIZAR PARA CABELLO SINTÉTICO O MOJADO

Ceramic plates with tourmaline that care the hair providing shine and softness.

- Maximum temperature: 200°C
- Power: 22W
- Safety thermostat
- Rubber cable 2 meters long
- Voltage 100-240V~
- Frequency: 50/60 Hz
- Heating of plates in just 30 seconds
- PTC resistance that prevents overheating
- To be used only on natural human hair
- DON'T USE FOR SYNTHETIC OR WET HAIR

Complementos



Accessories

u.m.vta: 1  24

REF. 02991





- Soporte para plancha estrecha tipo (06139). Con ventosas
- Stand for small straighteners (06139). With suction cups

u.m.vta: 1  12 

REF. 03076



- Protector de dedos para altas temperaturas
- Fingers protectors high temperatures



u.m.vta: 1  12 

REF.03857



- Guante 3 dedos protector altas temperaturas
- Glove 3 fingers protector high temperatures

Cepillo alisador Straightener brush

u.m.vta: 1  20 

REF. 04583



¿Quieres
saber más?
Do you want
to know more?

SCAN
ME!



- Temperatura entre 80°C y 230°C
- Potencia: 55W
- Termostato interno que evita el sobrecalentamiento
- Cable giratorio 360° de 2,5 m. de largo
- Voltaje 220-240V~
- Pantalla LCD
- Desconexión automática en 60 min. si no se usa
- Para cabello natural
- NO UTILIZAR PARA CABELLO SINTÉTICO O MOJADO

- Temperature ranging from 80°C to 230°C
- Power: 55W
- Internal thermostat that prevents overheating
- 360° swivel cable, 2.5 metres long
- Voltage 220-240V~
- LCD screen
- Switches off automatically after 60 minutes when idle
- For natural hair
- DO NOT USE FOR SYNTHETIC OR WET HAIR



Cepillo plancha vapor Steam brush straightener

u.m.vta: 1  12

REF. 04737/50



REF. 04737/58



REF. 04737/68



Nueva plancha de vapor con cepillo Eurostil de última generación y diseño. Permite alisar tu cabello sin dañarlo debido a su vapor de agua que protege al cabello contra la deshidratación durante el alisado. El cabello tendrá un aspecto y un acabado suave, brillante y sano. Uso profesional

- Temperatura: ajustable entre 150°C y 230°C
- Potencia 75W
- Termostato interno que evita el sobrecalentamiento
- Metros de cable: 2,5 m de cable con rotación 360°
- Voltaje 220-240V~
- Frecuencia: 50/60 Hz
- Pantalla LCD indicando temperatura
- Desconexión automática después de 60 minutos
- Resistencia: calentamiento en tan sólo 90 segundos, con resistencia PTC
- Ajuste temperatura mediante dial
- Función de vapor de agua
- Apta para cualquier tipo de cabello natural.
- NO UTILIZAR EN CABELLO SINTÉTICO

New Eurostil steam hair straightener with brush. It has cutting-edge technology and design that allows you to iron your hair without damaging it, as the water vapour protects your hair from dehydration during straightening. The hair will have a soft, shiny and healthy look and finish. For professional use.

- Temperature: can be adjusted from 150°C to 230°C
- Power 75W
- The internal thermostat prevents overheating
- Cable meters: 360° rotating and 2,5 m long
- Voltage 220-240V~
- Frequency: 50/60 Hz
- LCD screen indicating temperature
- The device will switch off automatically if it remains idle for over 60 minutes
- Resistance: warms up in only 90 seconds, using a PTC resistance
- Adjust temperature by dial
- Water vapour capability
- Suitable for all kinds of natural hair
- NOT SUITABLE FOR SYNTHETIC HAIR

Tenacillas rizadoras con rotación doble sentido

Curling tongs with rotation double direction

u.m.vta: 1  12

Potencia: 45W
Power: 45W

REF. 04637



Más información:
45W
More information:
45W

SCAN
ME!



- Temperatura ajustable entre 100°C y 220°C
- Termostato interno evita sobrecalentamiento
- Cable goma giratorio 360° y 2,5m largo
- Pantalla LCD
- Función auto desconexión seguridad
- Recubrimiento de los tubos en cerámica y turmalina
- Botones rotación tenacilla (derecha o izquierda)
- Mango blanco color perla
- Apta para cualquier cabello natural
- NO APTA PARA CABELLO SINTÉTICO O MOJADO

- Temperature adjustable between 100°C and 220°C
- Internal thermostat to prevent overheating
- 360° rubber swivel cable, 2.5 metres long
- LCD screen
- Auto-disconnect safety feature
- Tubes coated in ceramics and tourmaline
- Buttons to determine the direction in which the tongs twist (right or left)
- White pearl-like grip
- Suitable for all kinds of natural hair
- NOT SUITABLE FOR SYNTHETIC OR WET HAIR



Tenacillas rizadoras triple barra

Curling tongs triple barrel

u.m.vta: 1  10 

REF. 04594



Más
información
More
information

SCAN
ME!



- Temperatura ajustable entre 130°C y 220°C
- Potencia 65W
- Cable de goma giratorio 360° y 2,5 m de largo
- Auto-control universal voltaje 100-240V~
- Pantalla LCD
- Función de auto desconexión pasados 60 minutos sin actividad
- Recubrimiento de los tubos en cerámica y turmalina que cuidan el cabello proporcionando brillo y suavidad
- Sistema de calentamiento rápido y seguro
- Mango "soft-touch"
- Para cabello natural
- NO APTA PARA CABELLO SINTÉTICO O MOJADO

- Temperature adjustable between 130°C and 220°C
- Power 65W
- 360° rubber swivel cable, 2.5 metres long
- Automatic universal 100-240V~ voltage
- LCD screen
- Switches off automatically after remaining idle for 60 minutes
- Tubes coated in ceramics and tourmaline that care for hair, providing it with shine and softness
- Quick and safe heating system
- "Soft touch" handle
- For all kinds of natural hair
- NOT SUITABLE FOR SYNTHETIC OR WET HAIR



Tenacillas rizadoras con pinza
Curling tongs with clamp

u.m.vta: 1  12

REF. 01664

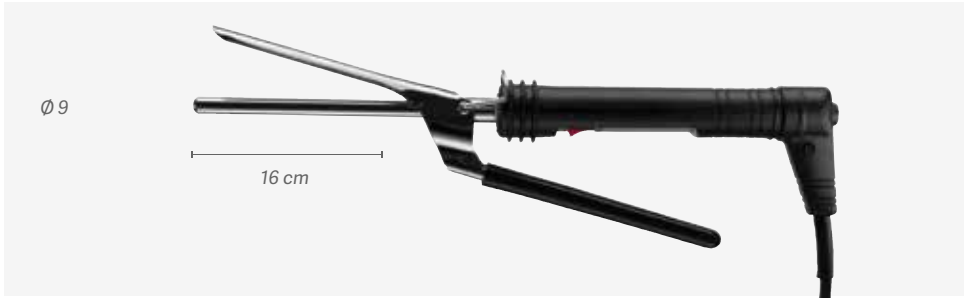

REF. 01981



REF. 01665



REF. 01666



REF. 01667



Tenacillas rizadoras con pinza

Curling tongs with clamp

u.m.vta: 1  12

REF. 01982

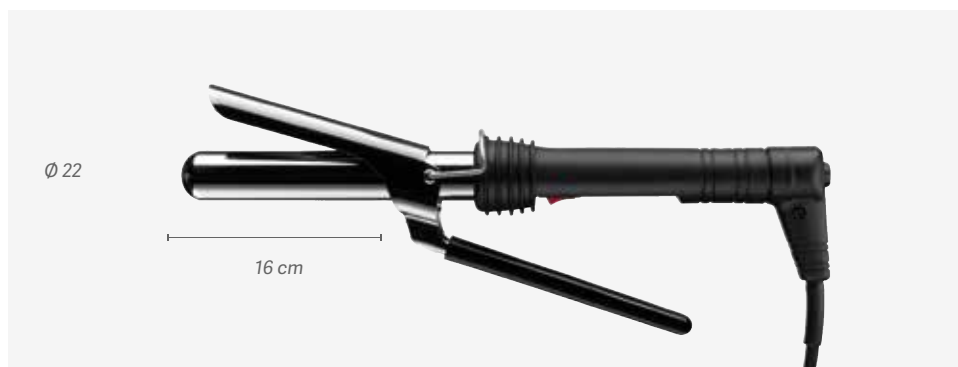

REF. 01668



REF. 02797

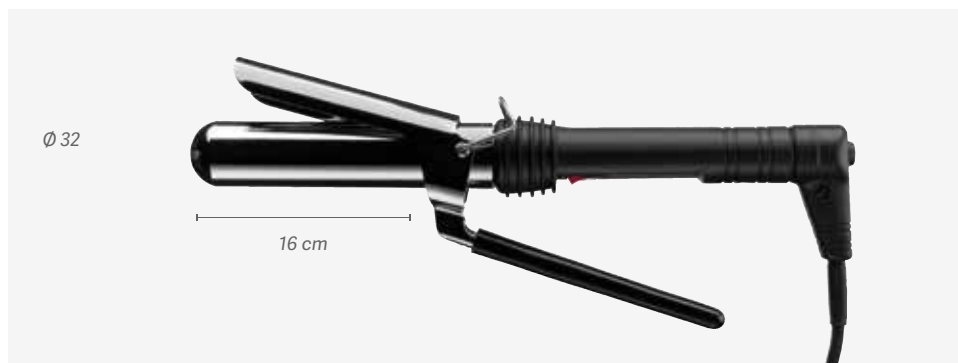

- Temperatura ajustable entre 185°C y 195°C
- Potencia: 25W
- Cable de goma giratorio 360° y 2,5 m de largo
- Voltaje: 230V~
- Frecuencia: 50Hz
- Con pinza



- Temperature adjustable between 185°C and 195°C
- Power: 25W
- 360° rubber swivel cable, 2.5 metres long
- Voltage: 230V ~
- Frequency: 50 Hz
- With clamp

Nuestra línea más clásica de tenacillas
Our most classic curling tongs line



Tenacillas cerámica turmalina

Ceramic tourmaline curling tongs

u.m.vta: 1  10 



- Temperatura de 80°C a 210°
- Potencia: 65W
- Termostato para evitar sobrecalentamiento
- Cable giratorio 360° de 2,5 m. de largo
- Pantalla LCD
- Desconexión automática después de 60 min. sin actividad
- Recubrimiento en cerámica y turmalina
- Sistema de calentamiento rápido y seguro
- Mantiene la temperatura constante
- Para cabello natural
- Mango soft touch

- Temperature: 80°C to 210°
- Power: 65W
- Thermostat to prevent overheating
- 360° rubber swivel cable, 2.5 metres long
- LCD screen
- Switches off automatically after remaining idle for 60 minute
- Ceramic and tourmaline coating
- Quick and safe heating system
- Keeps temperature at a constant level
- For natural hair
- "Soft touch" handle

REF. 04847



REF. 04848



REF. 04849



REF. 04850



REF. 04851





REF. 04852



Tenacilla cónica

Conic curling tong

u.m.vta: 1  10 

Ø 13-25

REF. 04593



Ø 19-32

REF. 04598



- Potencia 65W
- Temperatura ajustable entre 130°C y 220°C
- Cable de goma giratorio 360° y 2,5 m de largo
- Auto-control universal voltaje 100-240V-
- Pantalla LCD
- Función de auto desconexión pasados 60 minutos sin actividad
- Recubrimiento de los tubos en cerámica y turmalina que cuidan el cabello proporcionando brillo y suavidad
- Sistema de calentamiento rápido y seguro
- Mango "soft-touch"
- Para cabello natural
- NO APTA PARA CABELLO SINTÉTICO O MOJADO

- Power 65W
- Temperature adjustable between 130°C and 220°C
- 360° rubber swivel cable, 2.5 metres long
- Automatic universal 100-240V- voltage
- LCD screen
- Switches off automatically after remaining idle for 60 minute
- Tubes coated in ceramics and tourmaline that care for hair, providing it with shine and softness
- Quick and safe heating system
- "Soft touch" grip
- For all kinds of natural hair
- NOT SUITABLE FOR SYNTHETIC OR WET HAIR

Tenacilla cónica

Conic curling tong

u.m.vta: 1  12

REF. 03414



- Temperatura de 185°C a 195°C
- Potencia 25W
- Tubo de aluminio con tratamiento teflón
- Sistema de calentamiento rápido y seguro
- Mantiene la temperatura constante

- Temperature: 185°C to 195°C
- Power 25W
- Aluminium tube with teflon treatment
- Fast and safe heating system
- Maintains the temperature constant

Cepillo eléctrico térmico

Thermal electric brush

u.m.vta: 1  12

REF. 01949



- Temperatura de 185°C a 195°C
- Potencia: 25W
- Cable giratorio 360° de 2,5 m. de largo
- Voltaje: 230 V~
- Frecuencia: 50Hz
- Ideal para rizos suaves

- Temperature: 185°C to 195°C
- Power: 25W
- 360° rubber swivel cable, 2.5 metres long
- Voltage: 230 V~
- Frequency: 50 Hz
- Ideal for soft curls

Peine eléctrico antipiojos Medisana

Medisana electric comb anti lice

u.m.vta: 1  4

REF. 06584



- Elimina piojos y liendres con un simple cepillado
- Los piojos son destruidos por una corriente eléctrica al contacto con los dientes del peine
- Sin efectos secundarios porque no son necesarios productos químicos
- Pilas incluidas: 1 × 1,5v aa
- Peso: 95 gr aprox

- Eliminates lice and nits with a simple combing action
- Destroy lice with an electric current on contact with the teeth of the comb
- No side effects because no chemicals are necessary
- Batteries included: 1 × 1.5V aa
- Weight: 95 gr approx



Soldador tenacilla extensiones

Connector for hair extensions

u.m.vta: 1  20Potencia: 21W
Power: 21Wu.m.vta: 1  25Potencia: 26W
Power: 26W

REF. 02557

REF. 02558



Mezcladora recargable tinte

Rechargeable dye mixer

u.m.vta: 1  10

REF. 04092



Más
información
More
information

SCAN
ME!





- Potencia: 9W
- Voltaje: 100-240V~
- Mezcladora recargable (carga total 180 minutos y entonces trabaja 80 min)
- En vacío trabaja 100 minutos
- 4 bols con goma antideslizante de 400ml y 4 paletinas
- Se para si se abre la tapa
- Selección tiempo 45-60 y 75 s
- Con el botón manual on/off si se activa trabaja unos 3 minutos, y se para al igual si se detiene por algún motivo, pasados 3 minutos se desactiva
- Las hélices son de acero inoxidable recubierto en plástico
- Recambio tapa mezclador RE04092/01
- Recambio hélice mezclador RE04092/02
- Dimensiones: 156 x 126 x 139 mm

- Power: 9W
- Voltage: 100-240V~
- Rechargeable mixer (fully charged in 180 minutes, can run for 80 min)
- The device can run in test mode and in empty mode for 100 minutes
- 4 bowls (400 ml) with anti-slip rubber and 4 palettes
- Stops when the lid is opened
- The timer can be set to 45-60 and 75 s
- When the manual on/off is used, the device runs for up to 3 minutes until it is stopped for any reason or automatically, after 3 minutes
- The helixes are made from stainless steel sheathed in plastic
- Spare parts: replacement lid for mixer RE04092/01
- Spare parts: replacement helix for mixer RE04092/02
- Size: 156 x 126 x 139 mm



Esterilizador UV Eurostil plástico Eurostil plastic UV sterilizer

u.m.vta: 1  1 

REF. 06618

- Potencia: 8W
- Esterilizador de rayos ultravioleta para todo tipo de herramientas tanto de peluquería como de estética

- Power: 8W
- Ultraviolet ray sterilizer for all types of tools, both hairdressing and aesthetics



Recambio · Spare part

u.m.vta: 1  1

REF. RE06618/01

Recambio bombilla UV 8W
Bulb replacement UV lamp 8W

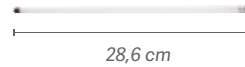

Esterilizador UV Eurostil aluminio Eurostil aluminum UV sterilizer

u.m.vta: 1  1

REF. 03317

- Potencia: 8W
- Indicado para la esterilización de pequeños utensilios en plástico o metal, mediante una bombilla de rayos UVC germicida
- No utilizar con otros objetos no indicados
- La bombilla dura unas 1300/1500 horas (= 1 año de funcionamiento)

- Power: 8W
- Recommended for sterilising small plastic or metal utensils; the device uses a UVC ray light bulb with a germicidal effect
- Should not be used with unsuitable objects
- The light bulb has a lifespan of 1300/1500 hours (= 1 year of use)



Esterilizador germicida gx4 Germicidal gx4 sterilizer



u.m.vta: 1  20



REF. 03009/59

- Potencia: 15W
- Temperatura de 20°C a 200°C
- Ultra plano. Luz germicida alta calidad

- Power: 15W
- Temperature: 20°C to 200°C
- Ultra flat. High quality germicidal light



Recambio · Spare part

u.m.vta: 1  1

REF. RE00891/01

Recambio bombilla UV
Bulb replacement UV lamp



Esterilizador calor seco Sanity Security Sanity Security hot dry sterilizer

u.m.vta: 1  1

REF. 03011

- Temperatura de 20°C a 200°C
- Potencia: 400W
- Medidas internas: 25 cm x 14,5 cm x 7 cm

- Temperature: 20°C to 200°C
- Power: 400W
- Internal measures: 25 cm x 14,5 cm x 7 cm



Esterilizador EUROSTIL cuarzo Quartz EUROSTIL sterilizer

u.m.vta: 1  6 

REF. 07013

- Potencia: 75W
- Voltaje: 220-240 V~
- Frecuencia: 50/60Hz



- Power: 75W
- Voltage: 220 - 240 V~
- Frequency: 50/60 Hz

- De cuarzo
- Ideal para utensilios metálicos, tijeras, etc.
- Incluye bolsa con bolitas de cuarzo

- Of quartz
- Ideal for metallic tools as scissors, etc.
- Includes bag with quartz beads



Bote esferas de cuarzo 500 g Steriliser quartz spheres 500 g

u.m.vta: 1  12 



REF. 06619

Para esterilizar herramientas metálicas tanto de peluquería como de estética.

To sterilize metal tools for, both hairdressing and aesthetics.



Aspirador de cabello Hair vacuum

u.m.vta: 1  1 

REF. 06612



SCAN
ME!



Depósito
Collection
Bin

Botón
Manual
Manual
button

Entrada
de la suciedad
Dirt Inlet

Sensores
Sensors

AUTO OFF
MANUAL
Dial de
control
AUTO OFF
MANUAL
Control dial

Indicador del
estado de la luz
Status
indicator
light

Filtro
Filter



Aspirador de cabello de última tecnología. En el modo manual, barre los escombros hacia la entrada en la base de la unidad. Pulse el botón de activación manual y deje que HAIR VACUUM aspire los escombros a través de la entrada y los almacene en el depósito.

1. El modo MANUAL tendrá una duración de 5 segundos. Dependiendo de la cantidad de desechos, puede ser necesario pulsar el botón de activación manual más de una vez.
2. Cuando el dial de control se gira a la posición AUTO, barre los desechos hacia la entrada en la base de la unidad y los sensores detectan los escombros e inician automáticamente un ciclo de aspiración que se terminará una vez que los sensores no detectan desechos.

- Potencia nominal: 1400 W
- Modelo: VA001A-BK
- Tensión nominal: 220-240V~
- Frecuencia: 50/60Hz
- Tamaño: (largo x ancho x alto): 33 cm largo x 21 ancho x 56,4 cm alto
- Peso neto: acerca de 5.1Kg
- Ruido de la operación: ≥ 83 db 1.5m
- Modo de trabajo automático: introducción de radiación infrarroja
- Succión (fuerza de tensión ≥ 2.8 Kg)
- Capacidad del tanque de basura: 2.7L MAX
- Tamaño de la exposición del cable de alimentación: 2m

Hair vacuum with the last technology. In the MANUAL mode, sweep debris towards the inlet at the base of the unit, press the manual activation button and let HAIR VACUUM vacuum the debris through the inlet and into the collection bin.

1. The MANUAL mode will run for 5 seconds. Depending on the amount of debris, it may be necessary to press the manual activation button more than once.
2. When the control dial is turned to the AUTO position, sweep debris towards the inlet at the base of the unit and the HAIR VACUUM sensors will detect the debris and automatically initiate a timed vacuuming cycle which will terminate once the HAIR VACUUM sensors no longer detect debris.

- Rated Power: 1400W
- Model: VA001A-BK
- Rated Voltage: 220-240V~
- Frequency: 50/60Hz
- Size: (long x wide x high): 33 cm long x 21 wide x 56.4 cm high
- Net weight: about 5.1Kg
- Operation noise: ≥ 83 db 1.5m
- Automatic working mode: infrared radiation induction
- Suction (tensile force): ≥ 2.8 Kg
- Garbage tank capacity: 2.7L MAX
- Power cord exposure size: 2m



02

Artículos tintura Dyeing accessories

*Boles, paletinas, básculas, capas,
guantes, papel aluminio, peñadores ...*

*Bowls, dye brushes, scales, capes,
gloves, aluminum, gowns ...*

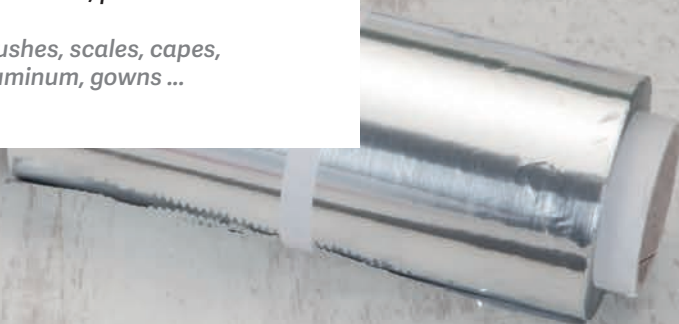

Accesorios
Accessories

u.m.vta: 36  36

REF. 00699

u.m.vta: 36  36

REF. 00971

u.m.vta: 12  120

REF. 03035

Espátula
aplicadora 18 cm
Aplicator spatule
18 cm

Esponja neutralizadora con soporte
Neutralizing sponge with support



Recambio esponja
Sponge spare



Paletas especiales mechas y balayage
Special shovel streaking and balayage

u.m.vta: 10  100 

REF. 01845

u.m.vta: 48  48

REF. 00977

u.m.vta: 10  120

REF. 02172

u.m.vta: 10  60

REF. 04284

NEW

Mod. Terraza



Las paletas son ideales para realizar trabajos de balayage y mechas californianas, ya que aportan un soporte donde apoyar los mechones de cabello para aplicar el tinte o la decoloración. El balayage es una técnica francesa que se puso de moda en los años 90, con la que se consigue una distribución uniforme de luminosidad en tu cabellera. La palabra "balayage" significa barrer y es precisamente así, barriendo el color desde la raíz hasta las puntas, como se consigue un look natural y luminoso. Son las mechas californianas clásicas, tanto para rubias como para morenas.

These palettes are ideal for balayage work and California highlights, as they provide a support on which to support locks of hair to apply the dye or bleach. Balayage is a French technique that became fashionable in the nineties and which provides a uniform spread of brightness on your hair. The word "balayage" means "to sweep", and it is precisely thus that, by sweeping colour from the root to the tips, a natural, bright look is achieved. They are the classic California highlights, both for blondes and brunettes.

Accesorios Accessories

u.m.vta: 1  25

REF. 02537

Llave para exprimir tubos con tira para colgar
Tube squeezer with hanging strip

u.m.vta: 1  6

REF. 02680

Peine ROLL-KA con aplicador de producto
ROLL-KA comb with product applicator





Exprimidor Tube squeezer

u.m.vta: 1  12

REF. 01959

Exprimidor aluminio pequeño
Small aluminum tube squeezer

u.m.vta: 1  84 

REF. 03398

Exprimidor plástico
Plastic tube squeezer

u.m.vta: 1  10

REF. 01496

Exprimidor aluminio grande
Large aluminum tube squeezer



Exprimidor Tube squeezer

u.m.vta: 60  60

REF. 01386

Exprimidor de tubos colores
Coloured tube squeezer

u.m.vta: 1  100

REF. 02590

Bolsa 10 exprimidores metálicos
Bag 10 metallic tube squeezers

u.m.vta: 12  240



REF. 03521

Bolsa 1 exprimidor metálico negro
Bag 1 black metallic tube squeezer



Caja de 200 tiras especiales para mechas plastificadas

Box 200 special laminated wicks strips

u.m.vta: 1  20 



REF. 04679



REF. 04679/53



REF. 04679/54



- 200 tiras de espuma de poliestireno
- Resistentes · ligeras · flexibles · térmicas
- Para una coloración rápida y fácil
- Consiga unos resultados óptimos con las tiras de espuma Eurostil
- Permiten aplicar el tinte más cerca de la raíz y conseguir el color deseado
- Ayuda a diferenciar las mechas de diferentes tonalidades con el color del papel, blanco, oro y plata
- Cada color de papel corresponderá a un color de mechas

CONSEJOS PRÁCTICOS DE USO:

- Para el cabello largo, coloque una tira debajo del mechón, aplique el tinte y dóblela uniendo los dos extremos
- No es necesario doblar los laterales de las tiras
- Las propiedades térmicas de las tiras Eurostil aceleran el proceso de coloración o decoloración. Compruebe el desarrollo regularmente
- Autoadhesivas: le permiten comprobar el proceso tantas veces como lo desee



- 200 polystyrene foam strips
- Sturdy - lightweight - flexible - thermal
- For quick and easy coloration
- Obtain optimal results using Eurostil foam strips
- They allow you to apply the dye closer to the roots and to achieve the desired colour
- They help differentiate highlights of different tones using the white, gold and silver paper colours
- Each paper colour corresponds to the colour of the different highlights

PRACTICAL USE ADVICE

- For long hair, place one strip beneath a strand of hair, apply the dye and fold it, joining both ends
- You do not need to fold the sides of the strips
- The thermal properties of Eurostil strips accelerate the dyeing or bleaching process. Be sure to check progress regularly
- Self-adhesive: they allow you to check the process as many times as you like

Caja 100 tiras especial mechas 0,8 mm

Box 100 streak strips 0,8 mm

u.m.vta: 2  2

REF. 03338

100 tiras = 63 g
100 strips = 63 g



Rollo Foam para mechas

Foam roll for streaks

u.m.vta: 1  3

REF. 07493

NEW

50 x 11 cm



Caja de 250 hojas grandes súper mechas 1,1 mm

Box 250 large streak paper 1,1 mm

u.m.vta: 1  6

REF. 01874

- Grosor: 1,1 mm
- Thickness: 1,1 mm



Caja 100 u. clips transparentes

Box 100 u. transparent clips

u.m.vta: 1  12

REF. 01025



Al ser transparentes permite seguir el proceso a "simple vista", sin necesidad de abrir y cerrar. Gracias a su sistema adhesivo no hay escapes, quedando más cerca de la raíz.

It allows to follow the process at "first sight" to be transparent, without the need to open and close. Thanks to its adhesive system there are no leak being closer to the root.

Temporizador

Timer

u.m.vta: 1  12 

REF. 01975



Temporizador digital

Digital timer

u.m.vta: 1  25

REF. 02539/50

- Voltaje: 9V~
- Con soporte e imán
- Voltage 9V ~
- With support and magnet



Balanzas digitales EUROSTIL

EUROSTIL digital scales

u.m.vta: 1  6 

REF. 03337/50

REF. 03337/54



- Voltaje: 9V~
- Display LCD
- Rango de medición hasta 5 kg
- Unidad de medida 1 g
- Unidades de medida ajustables a kilogramos o libras
- Función tara (peso bruto con recuerdo de tara)
- Placa de apoyo en vidrio, grande y estable, para pesar con exactitud
- Baterías no incluidas



- Voltage 9V ~
- LCD display
- Can measure up to 5 kg
- Unit of measurement 1 g
- Measuring units adjustable to kg or lbs
- Tare function (gross weight with tare memory)
- Glass support plate, large and stable, to weigh accurately
- Batterie not included

Balanzas digitales redondas EUROSTIL

EUROSTIL round digital scales

u.m.vta: 1  10 



REF. 04803/50



REF. 04803/58





- Diseño moderno
- Capacidad: 5 kg / 11 libras: 0,4 oz / 176 oz / 5 L
- Escala: 1g / 0.1oz / 1 ml
- Función tara
- Función apagado automático
- Indicación del estado de la batería
- Cuatro unidades de medida diferentes: g / lb:oz / oz / ml
- Funciona con batería de litio CR2032 (no incluida)

- Modern design
- Capacity: 5 kg / 11 lbs: 0.4 oz / 176 oz / 5 L
- Scale: 1g / 0.1oz / 1 ml
- Tare function
- Auto power off function
- Battery status Indication
- Four different units of measure: g / lb: oz / oz / ml
- Works with CR2032 lithium battery (not included)

Balanzas digitales rectangulares EUROSTIL

EUROSTIL rectangular digital scales

u.m.vta: 1  6 



REF. 04804/50





REF. 04804/58



Balanza digital redonda TASSEL

TASSEL round digital scale

u.m.vta: 1  10 

REF. 06631



Bol graduado con goma antideslizante

Non-slip rubber graduated bowl

u.m.vta: 32  32Colores standard
Standard colours

REF. 00647

Negro
Black

REF. 00647/50

Colores clásicos
Classic colours

REF. 00647/98



Bol con goma antideslizante

Non-slip rubber bowl

u.m.vta: 32  32Transparente
Transparent

REF. 00647/56

Translúcido
Translucent

REF. 00647/76



Bol para tinte pequeño
Dye small bowl

u.m.vta: 72  72

Colores standard
Standard colours

REF. 00654



Negro
Black

REF. 00654/50



Colores clásicos
Classic colours

REF. 00654/98



Bol para tinte grande
Dye big bowl

u.m.vta: 48  48

Translúcido
Translucent

REF. 00655/56



Negro
Black

REF. 00655/50



Colores standard
Standard colours

REF. 00655



Bol antideslizante "TERRAZA" "TERRAZA" non-slip dye bowl

u.m.vta: 48  48Translúcido
Translucent

REF. 03696



REF. 03696/50



Bol TASSEL "TERRAZA" "TERRAZA" TASSEL dye bowl

u.m.vta: 48  48

REF. 06426



Bol graduado con asa Graduated bowl with handle

u.m.vta: 40  40

REF.02340

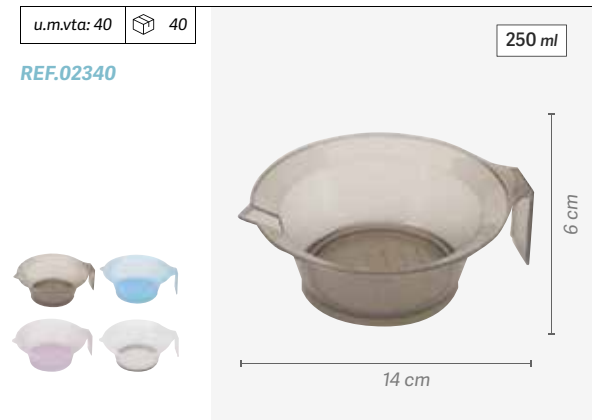

Bol graduado con goma antideslizante y asa Non-slip rubber graduated bowl and handle

u.m.vta: 40  40Translúcido
Translucent

REF. 02341

Colores metalizados
Metallic colours

REF. 02341/97



Bol graduado SAVE SAVE graduated bowl

u.m.vta: 20	 20
-------------	--



REF. 04967/50



REF. 04967

Bol de plástico provisto de una parte estriada con el fin de definir la cantidad de producto según su necesidad, facilitando así la retirada de este.

Plastic bowl with a grooved part in order to define the quantity of product according to your need, thus facilitating the withdrawal of this.

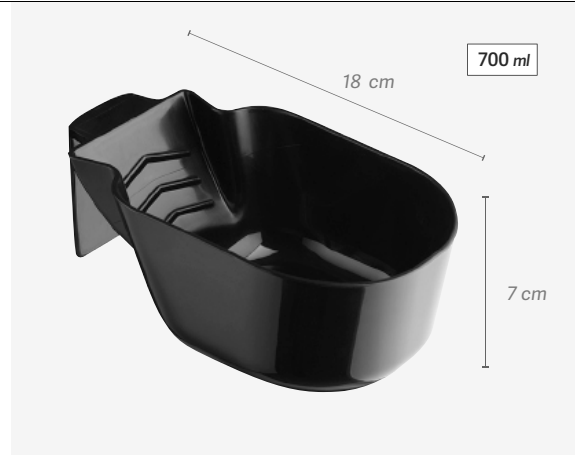

Bol para tinte y para colgar en carros Dye bowl to hang in trolleys

Transparente
Transparent

u.m.vta: 8	 8
------------	---

450 ml

REF. 01169

u.m.vta: 14	 14
-------------	--

250 ml

REF. 01170

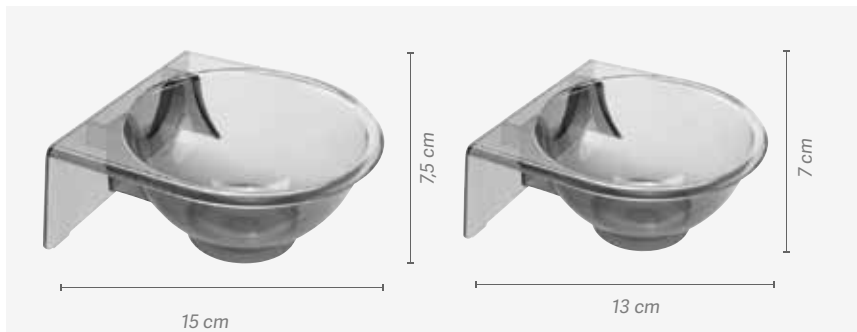

Bol de tinte colgante en superficie máxima de 1.5 cm de grosor. Práctico para la aplicación del tinte, favoreciendo una cómoda, rápida y limpia aplicación. (Véase foto adjunta).

Hanging dyeing bowl on a maximum surface of 1.5 cm in thickness. Practical for the application of the dye, favoring a comfortable, fast and clean application. (See attached photo).

Bol grande plástico reciclado Big recycled plastic bowl

u.m.vta: 1	 48
------------	--

REF.00655/222



Paletinas pequeñas para tinte · Small dye brushes

Granel
In bulk

Bolsa individual
Individual bag

u.m.vta: 144  144

u.m.vta: 1  100 

REF. 00101/01

REF. 00101

Colores standard
Standard colours



REF. 00101/50/01

REF. 00101/50

Negra, con pelo negro
Black, with black hair



REF. 00101/56/01

REF. 00101/56

Transparente
Transparent

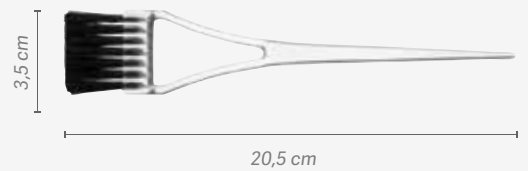

Bolsa individual
Individual bag

u.m.vta: 1  100 

REF. 00101/97

Colores metalizados
Metallic colours

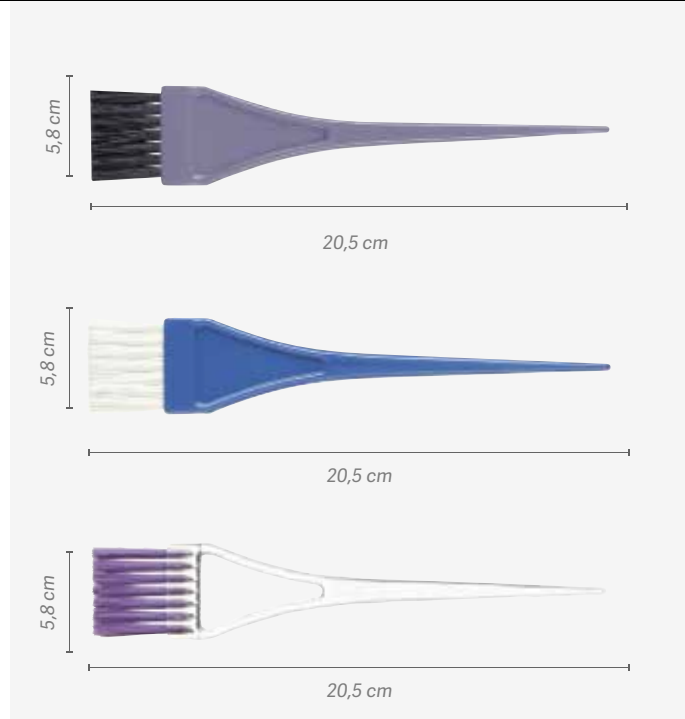
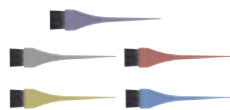

REF. 00101/98

Colores "classic"
"Classic" colours



REF. 00101/56/99

Transparentes con pelo de color
Transparent with coloured bristles



Paletinas grandes para tinte · Large dye brushes

Granel
In bulk

Bolsa individual
Individual bag

u.m.vta: 72  72

u.m.vta: 1  50 

REF. 00102/01

REF. 00102

Colores standard
Standard colours

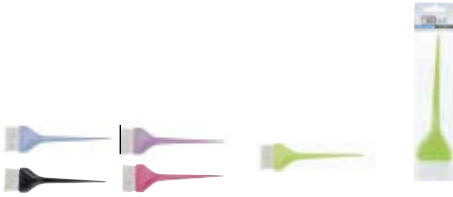

REF. 00102/50/01

REF. 00102/50

Negra, con pelo negro
Black, with black hair



REF. 00102/56/01

REF. 00102/56

Transparente
Transparent

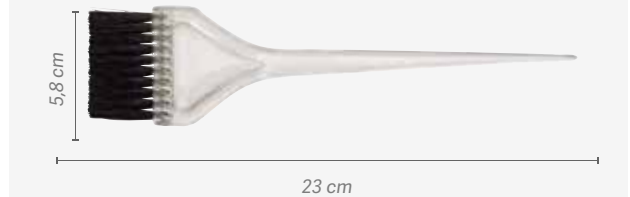

Bolsa individual
Individual bag

u.m.vta: 72  72

REF. 00102/97

Colores metalizados
Metallic colours

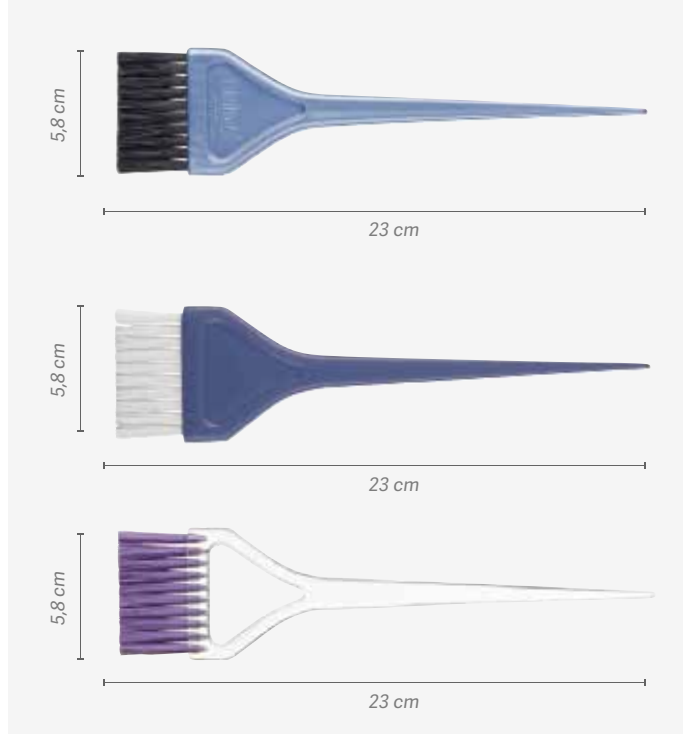

REF. 00102/98

Colores "classic"
"Classic" colours



REF. 00102/56/99

Transparentes con pelo de color
Transparent with coloured bristles





Paletina translúcida "TERRAZA"
"TERRAZA" translucent dye brush

u.m.vta: 72  72

Granel
 In bulk

REF. 03697/01



u.m.vta: 1  50 

Bolsa individual
 Individual bag

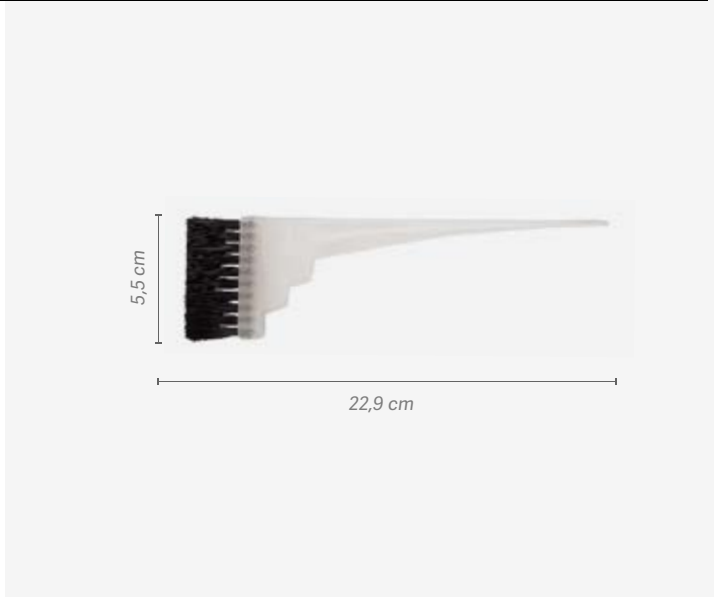
REF. 03697



Paletina grande TASSEL "TERRAZA"
TASSEL "TERRAZA" large dye brush

u.m.vta: 1  50 

REF. 06425



Paletina para tinte con púas pulidas SOFTLY
SOFTLY dye brush with polished bristles



Bolsa individual
 Individual bag

u.m.vta: 1  100 

REF. 04654

Pequeña
 Small



u.m.vta: 1  50 

REF. 04655

Grande
 Large

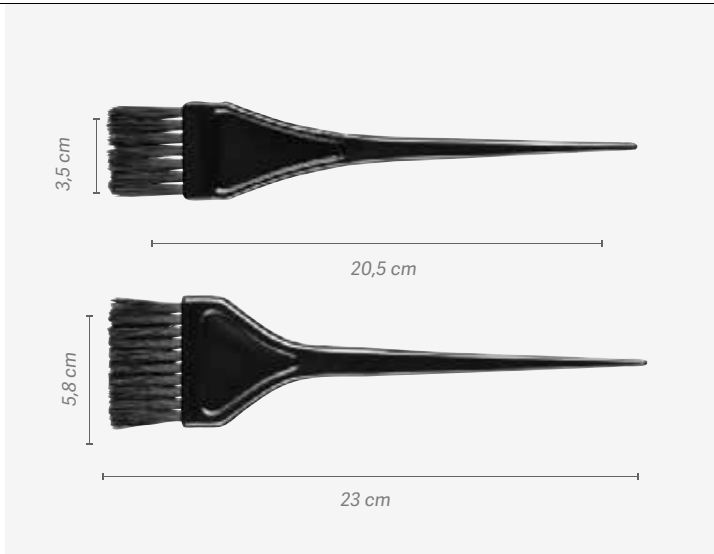

Paletina grande especial para tinte
Special large dye brush

Bolsa individual
 Individual bag

u.m.vta: 1  180 

REF. 01335

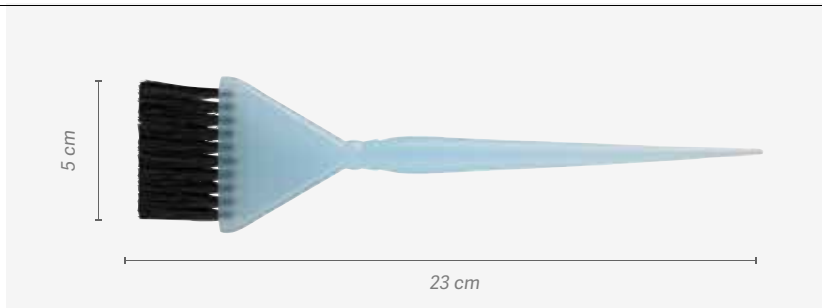

Paletina mediana especial para tinte
Special medium dye brush

u.m.vta: 1  75 

Bolsa individual
 Individual bag

REF. 01280

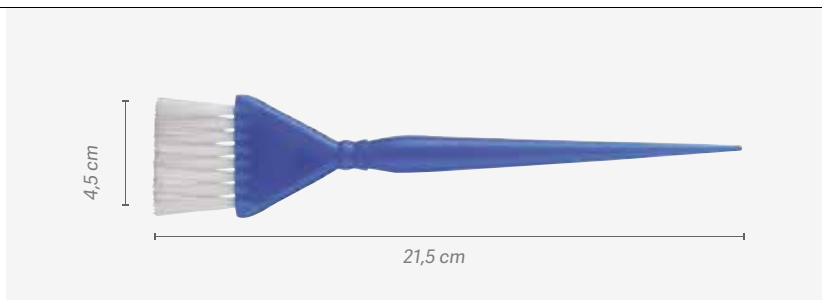

Paletina pequeña para tinte
Small dye brush

Bolsa individual
 Individual bag

u.m.vta: 1  90 

REF. 01334

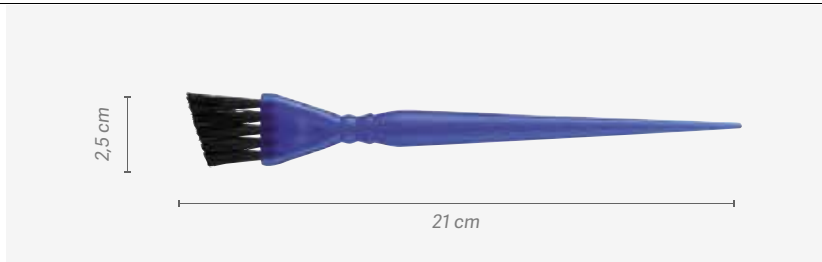

Paletina con púas de plástico
Plastic bristles dye brush



u.m.vta: 100  100

REF. 03033



Paletinas de silicona para tinte Silicone dye brush

Bolsa individual
Individual bag

u.m.vta: 1  60 

REF. 04297



- Recta y grande
- Large and straight



Paletinas de silicona para la aplicación del tinte de una forma más precisa y rápida:

- Aplicación más rápida
- Más próximo al cuero cabelludo
- Mayor ahorro de producto

Silicone dye brushes to apply dye more quickly and accurately:

- Quicker application
- Closer to the scalp
- Allows you to save on products

REF. 04298

- Inclínada y grande
- Large and slanted





REF. 04299

- Puntas medianas
- Medium tips



Paletina tinte despuntada plástico Plastic blunt dye brush



Bolsa individual
Individual bag

u.m.vta: 1  36 

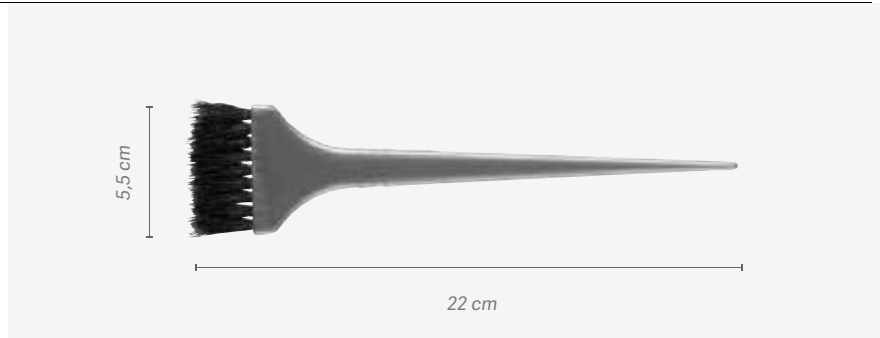
REF. 04739



Paletina material reciclado grande
Large recycled material palette

u.m.vta: 1  50 

REF.00102/222



Paletinas con peine
Dye brushes with comb

u.m.vta: 1  60 

REF. 02529/50



u.m.vta: 12  756

REF. 01128



Bote 24 paletinas
Bin 24 dye brushes

u.m.vta: 2  2

MOD.102

REF. 04682



Protector cuello
Neck protector

u.m.vta: 1 6

REF. 01464

- Protector de cuello para lavacabezas
- Neck protector for wash basin



u.m.vta: 1 60

REF. 03258

- De silicona con ventosas
- Silicone with pads



u.m.vta: 1 8

REF. 01363

- Bolsa 2 ud. fundas lavacabezas negras
- Bag 2 u. black wash basin covers



u.m.vta: 1 20

REF. 02522/50

- Protector cuello plástico negro
- Black plastic neck protector



u.m.vta: 1 10

REF. 02370

- Jofaina soft
- Neck tray soft



u.m.vta: 1 5

REF. 04507/50

REF. 04507/60

REF. 04507/62

- Protector cuello silicona para lavacabezas
- Silicone neck protector for wash basin



Probeta graduada
Measure tub test

u.m.vta: 1  40

- **Probeta graduada**
- *Measure tube test*

REF. 02530/50



u.m.vta: 32  32

- **Modelo TERRAZA**
- *TERRAZA model*

REF.04285



u.m.vta: 36  36

100 ml

REF. 00609

u.m.vta: 24  24

150 ml

REF. 00604

u.m.vta: 16  16

250 ml

REF. 00608



Coctelera graduada de plástico
Measure plastic shaker

u.m.vta: 24  24

160 ml

REF. 01846

u.m.vta: 18  18

210 ml

REF. 01144







u.m.vta: 16  16

350 ml

REF. 00978



Botella medidor / aplicador Measurer bottle / applicator

u.m.vta: 1	 24		u.m.vta: 1	 25		u.m.vta: 1	 24	
------------	--	---	------------	--	---	------------	--	---

60 ml







REF. 01112

120 ml

REF. 01235

120 ml

REF. 02527/50

u.m.vta: 1	 24		u.m.vta: 1	 96		u.m.vta: 1	 24	
------------	--	---	------------	--	---	------------	--	---

250 ml

REF. 01111

250 ml



REF. 01956

260 ml

REF. 02528/50



Conjunto de 3 embudos en 3 tallas mini Set 3 funnels 3 mini sizes



u.m.vta: 1	 70	
------------	--	---

REF. 00997

- Para perfumería, peluquería
- For perfumery, hairdressing



Cucharita dosificadora Measuring spoon

u.m.vta: 1	 350	
------------	---	---

REF. 01164



Rollo de papel de aluminio de colores

Aluminum foil roll colours

u.m.vta: 8  8

REF. 01113



REF. 01113/53



REF. 01113/59



REF. 01113/62

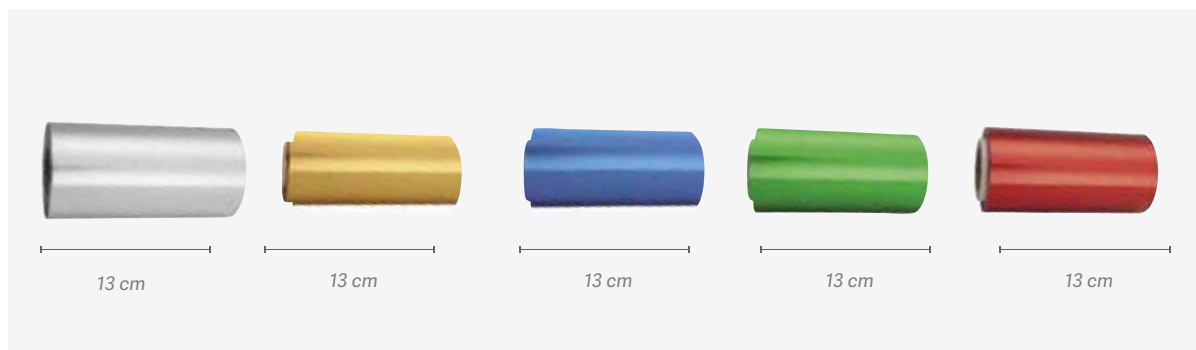

REF. 01113/60

125 m
Aprox

- Peso bruto: 600 g
- Peso neto sin mandril: 537 g
- Grosor: 13 micras +/-

- Gross weight: 600 g
- Net weight without mandrel: 537 g
- Thickness: 13 microns +/-

u.m.vta: 6  6

REF. 02964



REF. 02964/53



REF. 02964/59



REF. 02964/62

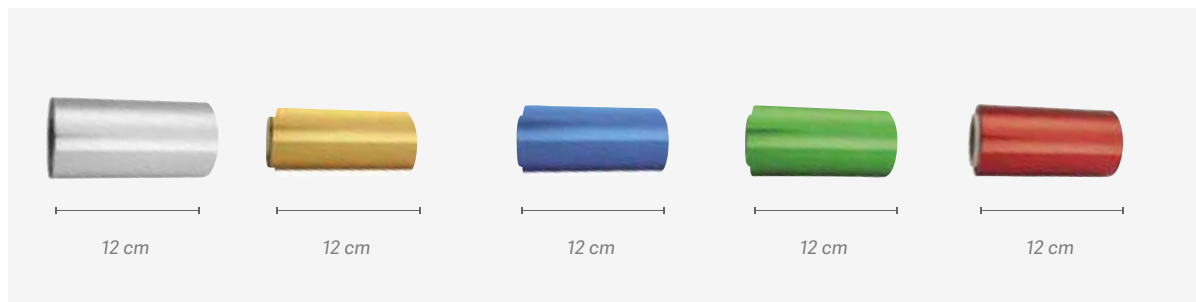

REF. 02964/60

100 m
Aprox

- Peso bruto: 475 g
- Peso neto sin mandril: 425 g
- Grosor: 15 micras +/-
- Con hoja de corte incorporada muy afilada

- Gross weight: 475 g
- Net weight without mandrel: 425 g
- Thickness: 15 microns +/-
- With very sharp blade built-in



Rollo de papel de aluminio

Aluminum foil roll

u.m.vta: 6  6

REF. 01139

- Peso bruto: 1.050g
- Grosor: 13 micras +/-
- Gross weight: 1.050 g
- Thickness: 13 microns +/-



Rollo PVC mandril

PVC film roll

u.m.vta: 6  6

REF. 01198



Rollo de papel de aluminio

Aluminum foil roll

u.m.vta: 1  36

60 m
Aprox



REF. 02531

Con franja transparente
With transparent window



Rollo papel aluminio 100 m plata

Silver aluminum foil roll 100 m

u.m.vta: 1  12 



REF. 07471

- Dimensión rollo 100 m x 15 cm x 15 micras
- Color plata
- Roll measurements: 100 m x 15 cm x 15 microns
- Silver colour



Rollo film PVC precortado 300m x 30cm

Roll of pre-cut PVC film 300m x 30cm

u.m.vta: 1  3 

REF. 07469





- Material: PVC FILM
- Largo: 300 metros; Ancho 30 cm
- Precortado cada 30 cm

- Material: PVC FILM
- Length: 300 metres; Width 30 cm
- Pre-cut every 30 cm

Rollo film PVC precortado 300m x 15cm

Roll of pre-cut PVC film 300m x 15cm



u.m.vta: 1  3 

REF. 07470



- Material: PVC FILM
- Largo: 300 metros; Ancho 15 cm
- Precortado cada 15 cm

- Material: PVC FILM
- Length: 300 metres; Width 15 cm
- Pre-cut every 15 cm

u.m.vta: 1  6 

REF. 06081



- De excelente calidad y gofrado, rollo de papel de aluminio de aproximadamente 18 micras y peso bruto de 400 g
- Gracias a su gofradura, el cabello respira más en la realización de las mechas y tinturas, favoreciendo un mejor resultado del trabajo realizado
- 9 metros de largo por 12 cm de ancho

- Of excellent quality and goffered, aluminum foil roll of approximately 18 microns and gross weight of 400 g
- Thanks to its embossing, the hair breathes more in the realization of the wicks and dyes, favoring a better result of the work done
- 9 meters long by 12 cm wide



Caja dispensadora 300 hojas

Dispenser box 300 sheets

u.m.vta: 1  24 

REF. 06193

- Papel de aluminio gofrado de 27x12cm
- 27x12cm goffered aluminum foil



Dispensador Dispenser

u.m.vta: 1  1

REF.02426



Protectores Protectors

u.m.vta: 1  100

REF.03217

- Bolsa 180 u.
- Protector para gafas
- Bag 180 u.
- Glasses protector

u.m.vta: 1  20

REF.03634

- Bolsa 50 u.
- Protector para el respaldo de la silla
- Bag 50 u.
- Back chair protectors

54 x 5,5 x 23 cm

u.m.vta: 1  50

REF.03633

- Caja 200 u. Protector para el móvil
- Box 200 u. Cell phone protector

u.m.vta: 30  30

REF. 01915

- Bolsa 2 u. Protector de orejas
- Bag 2 u. Ears protectors



Protector orejas 50 unidades
Ear hood 50 units

u.m.vta: 1  50

REF. 07008

- Dimensiones: 2*4.5 cm
 - Peso: 0,40 g
 - Material plástico
- Dimensions 2*4.5 cm
 • Weight 0,40 g
 • Plastic



100 guantes de un solo uso
100 disposable gloves

u.m.vta: 1  1



REF.00680

Material: plástico LPDE polietileno de baja presión
 Características: lisos, incoloro
 Talla: grandes ambidiestros

Material: low pressure LDPE polyethylene plastic
 Characteristics: smooth, colorless
 Size: large ambidextrous



Bolsa 100 guantes desechables
Bag 100 disposable gloves

u.m.vta: 1  100 

REF. 07304





Bolsa 200 guantes plástico
Bag 200 plastic gloves

u.m.vta: 1  50

REF. 00963



100 guantes de un solo uso
100 disposable gloves

u.m.vta: 1  25 

REF. 07257

- Ambidestro permite usar cada guante para cualquier mano
 - Talla única
 - Multiuso
 - 80g
- Ambidextrous allows each glove to be used for any hand
 • One size
 • Multipurpose
 • 80g



100 guantes polietileno transparente

100 transparent polyethylene gloves

u.m.vta: 1  100

REF. 07804

- 100% polietileno virgen hdpe 0,7 +/- 2% g/pc
- Hipoalergénicos, impermeables, talla única
- EPI categoría 1
- Confeccionado y marcado CE, compatible con uso alimentario 2011/10/CE
- 30 cm alto x 25 cm ancho dedos x 15 cm ancho muñeca

- 100% Hdpe virgin polyethylene 0,7 +/- 2% g/pc
- Hypoallergenic, unpermeable, one size
- Category EPI 1
- CE made & marked, compatible with food use 2011/10/CE
- 30 cm high x 25 cm width between fingers x 15 cm width wrist



Bolsa 2 u. guantes profesionales

Bag 2 u. professional gloves

u.m.vta: 1  246,5
Talla / Size

REF.01672

7
Talla / Size

REF.01673

7,5
Talla / Size

REF.01674

8
Talla / Size



REF.01675



- Material: caucho
- Material: rubber

Caja 100 guantes nitrilo negros

Box 100 black nitrile gloves

u.m.vta: 1  10 

S

REF. 06686

M

REF. 06687

L

REF. 06688

SIN polvo
Powder FREENITRILLO / NITRILE
AQL 1,5

Cumple normativa / Regulatory compliance:

EN ISO 21420:2020, EN ISO 374-1: 2016 + A1:2018 /TYPE B, EN ISO 374-5: 2016
CE ACORDE CON EL MODULO C2 DEL REGLAMENTO DEL PARLAMENTO EU Y DEL CONSEJO 2016/425 COMO PRODUCTO EPI DE CATEGORIA III
CUMPLE CON AQL 1,5

EN ISO 21420:2020, EN ISO 374-1: 2016 + A1:2018 /TYPE B, EN ISO 374-5: 2016
CE ACCORDING TO MODULE C2 OF THE REGULATION OF THE EU PARLIAMENT AND OF THE COUNCIL 2016/425 AS A PPE PRODUCT OF CATEGORY III
COMPLIES WITH AQL 1.5

Caja de 100 guantes de vinilo

Box 100 vinyl gloves

u.m.vta: 1  10 

S

REF. 06689

M

REF. 06690

L

REF. 06691

SIN polvo
Powder FREEVINILO / VINYL
AQL 1,5



Cumple normativa / Regulatory compliance:

EN ISO 21420:2020, EN ISO 374-1: 2016 + A1:2018 /TYPE B, EN ISO 374-5: 2016
CE ACORDE CON EL MODULO C2 DEL REGLAMENTO DEL PARLAMENTO EU Y DEL CONSEJO 2016/425 COMO PRODUCTO EPI DE CATEGORIA III
CUMPLE CON AQL 1,5

EN ISO 21420:2020, EN ISO 374-1: 2016 + A1:2018 /TYPE B, EN ISO 374-5: 2016
CE ACCORDING TO MODULE C2 OF THE REGULATION OF THE EU PARLIAMENT AND OF THE COUNCIL 2016/425 AS A PPE PRODUCT OF CATEGORY III
COMPLIES WITH AQL 1.5



Caja de 50 guantes sintéticos
Box 50 synthetic gloves

u.m.vta: 1  20 

L

REF. 07264



- Combina la flexibilidad del látex y la elasticidad del vinilo inodoro
 - Sensación de una segunda piel gracias a sus propiedades elásticas muy similares al látex y ofrece las propiedades hipo alergénicas del vinilo
 - Material: derivado del PVC
 - No estériles
 - Color negro
 - Superficies interna y externa lisas
 - Adecuados para alérgicos al látex
-
- *Combines the flexibility of latex and the elasticity of odorless vinyl*
 - *Second skin sensation thanks to its elastic properties very similar to latex and offers the hypoallergenic properties of vinyl*
 - *Material: derived from PVC*
 - *Not sterile*
 - *Black color*
 - *Smooth internal and external surfaces*
 - *Suitable for those allergic to latex*



SIN polvo
Powder FREE



Caja de 20 guantes de látex negros
Box 20 black latex gloves

u.m.vta: 1  24 

S

REF. 02832

M

REF. 02833

L

REF. 02834



SIN polvo
Powder FREE





LÁTEX / LATEX
AQL 1,5

Cumple normativa / Regulatory compliance:

CUMPLE CON EN 420:2003+A1:2009
 EN ISO 374-1: 2016 + A1:2018 / TYPE C
 EN ISO 374-5: 2016
 CE ACORDE CON EL MODULO C2 DEL
 REGLAMENTO DEL PARLAMENTO EU Y DEL
 CONSEJO 2016/425 COMO PRODUCTO EPI
 DE CATEGORIA III
 CUMPLE CON AQL 1,5 Y M=9,0G

EN ISO 420:2003+A1:2009
 EN ISO 374-1: 2016 + A1:2018 / TYPE C
 EN ISO 374-5: 2016
 CE ACCORDING TO MODULE C2 OF THE
 REGULATION OF THE EU PARLIAMENT AND OF
 THE COUNCIL 2016/425 AS A PPE PRODUCT
 OF CATEGORY III
 COMPLIES WITH AQL 1.5

Caja de 100 guantes de látex blancos con poco polvo
Box 100 white latex gloves with minimal powder

u.m.vta: 1  10 

S

REF. 01671

M

REF. 01669

L

REF. 01670

LÁTEX / LATEX

AQL 1,5





Cumple normativa / Regulatory compliance:

CUMPLE CON EN 420:2003+A1:2009
 EN ISO 374-1: 2016 / TYPE B
 EN ISO 374-5: 2016
 CE ACORDE CON EL MODULO C2 DEL
 REGLAMENTO DEL PARLAMENTO EU Y DEL
 CONSEJO 2016/425 COMO PRODUCTO EPI
 DE CATEGORIA III
 CUMPLE CON AQL 1,5

EN ISO 420:2003+A1:2009
 EN ISO 374-1: 2016 / TYPE CB
 EN ISO 374-5: 2016
 CE ACCORDING TO MODULE C2 OF THE
 REGULATION OF THE EU PARLIAMENT AND OF
 THE COUNCIL 2016/425 AS A PPE PRODUCT
 OF CATEGORY III
 COMPLIES WITH AQL 1.5

Caja de 100 guantes de vinilo
Box 100 vinyl gloves

u.m.vta: 1  10 

S

REF. 02586

M

REF.02587

VINILO / VINYL

AQL 1,5



SIN polvo
Powder FREE



Peinadores caucho Eurostil
Eurostil rubber gown

u.m.vta: 1  24

REF.01350





Peinadores de goma BOB-TUO
BOB-TUO rubber gown

u.m.vta: 1  12

REF.01082



Peinador profesional de silicona
Professional silicone gown

u.m.vta: 1  24 

REF. 03735



Peinador con cierre magnético
Magnetic closure gown

u.m.vta: 1  48

REF.02496





Peinador profesional reforzado
Reinforced professional gown

u.m.vta: 1  20

REF.00666/50



Peinador con cierre magnético
Magnetic closure gown

u.m.vta: 1  12 

REF. 02518/50





REF. 02519/50

REF. 02519/54



Peinador silicona EUROSTIL
EUROSTIL silicone gown

u.m.vta: 1  10 

REF.07006



Peinador profesional
Professional gown

u.m.vta: 1  12



REF.02595/50



REF.02595/58



REF.02595/70



REF.02595/59

- Material: nylon
- Cierre velcro

- Material: nylon
- Closure velcro

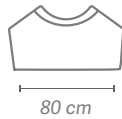

u.m.vta: 1  12



REF.02598/68



REF.02598/64

- Material: nylon
- Cierre velcro

- Material: nylon
- Closure velcro

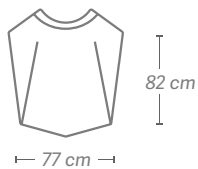

Bolsa 50 delantales desechables

Bag 50 disposable aprons

u.m.vta: 1  20

REF. 07266

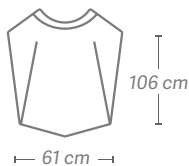

- Material: PE
- Grosor: 18 micras aprox.
- Peso cada delantal 10g
- Delantal ideal para proteger la ropa
- Uso único para una higiene impecable

- Material: PE
- Thickness 18 microns approx.
- Weight per apron 10g
- Disposable apron ideal to protect your clothes
- Disposable for impeccable hygiene

Bolsa 30 capas blancas

Bag 30 white capes

u.m.vta: 1  50

REF. 01078

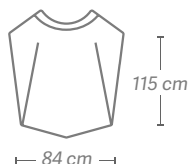

- Material: Polietileno baja densidad LDPE
- Cierre lazo
- Espesor plástico 20 micras
- Peso 340 g.

- Material: Low density polyethylene LDPE
- Closure tie
- Thickness 20 microns approx.
- Weight 340 g

Bolsa 30 capas negras de un solo uso

Bag 30 disposable black capes

u.m.vta: 1  50

REF. 07243

- Un solo uso
- Single use

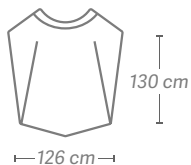

Bolsa de 50 capas de un solo uso
Bag 50 disposable capes

u.m.vta: 1  12

- 
REF. 07806/50
- 
REF. 07806/58
- 
REF. 07806/59

- Material P.E
- Cierre lazo
- Grosor: 12,5 micras aprox.

- Material P.E
- Closure tie
- Thickness 12,5 microns approx.

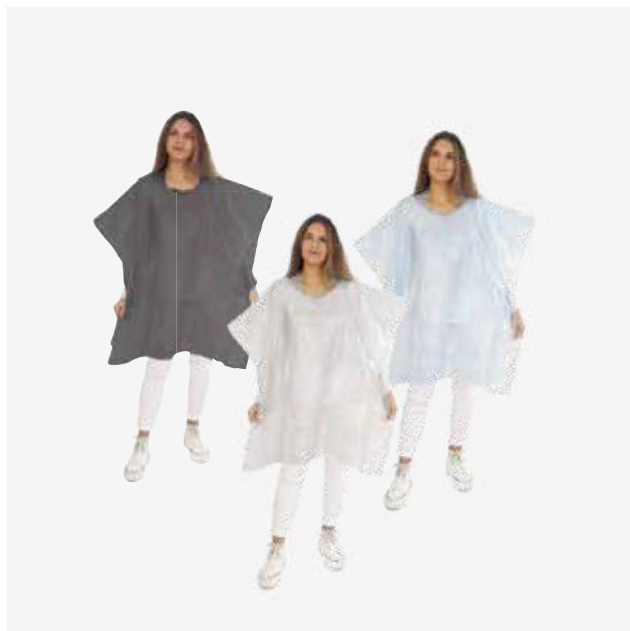
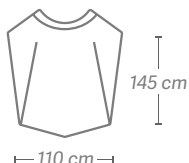

Bolsa de 30 capas CLASSIC
Bag 30 CLASSIC capes

u.m.vta: 30  30

- 
REF.02791/58
- 
REF.02791/50
- 
REF.02791/54
- 
REF.02791/59
- 
REF.02791/68
- 
REF.02791/70
- 
REF.02791/53

- Material: plástico
- Cierre lazo
- Grosor: 14 micras aprox.

- Material: plastic
- Closure tie
- Thickness 14 microns approx.

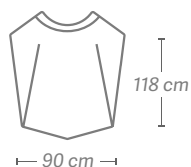

Bolsa 50 capas SIMPLE

Bag 50 SIMPLE capes

u.m.vta: 24  24

REF. 01207

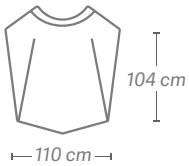

- Material: plástico
- Cierre lazo
- Azul
- Material: plastic
- Closure tie
- Blue



Bolsa 30 capas TASSEL

Bag 30 TASSEL capes

u.m.vta: 1  30

REF. 06427

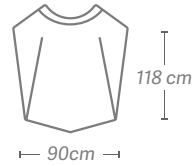

- Material: plástico
- Cierre lazo
- Blanca
- Material: plastic
- Closure tie
- White



Bolsa de 50 capas de un solo uso

Bag 50 disposable capes

u.m.vta: 24  24

REF.02456/58



REF. 02456/59



REF. 02456/60



REF. 02456/64



REF. 02456/68



REF. 02456/70

- Material P.E
- Cierre lazo
- Grosor: 12,5 micras aprox.

- Material P.E
- Closure tie
- Thickness 12,5 microns approx.

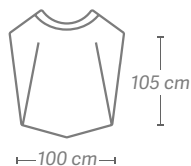

Rollo de 50 capas de un solo uso
Roll 50 disposable capes

u.m.vta: 12  12



REF. 02792/58



REF.02792/50





REF. 02792/59

- Material P.E
- Cierre lazo
- Grosor: 20 micras aprox.

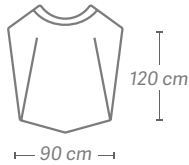
- Material P.E
- Closure tie
- Thickness 20 microns approx.



Bolsa de 30 capas WHITE
Bag 30 WHITE capes

u.m.vta: 1  40 

REF. 06113/58

- Material: polietileno
- Cierre lazo
- Grosor: 11 micras aprox.
- Para colgar

- Material: polyethylene
- Closure tie
- Thickness 11 microns approx.
- Ready to hang

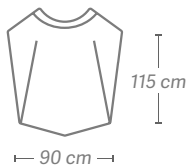

Capa poliéster negra con mangas
Black polyester cape with sleeve

u.m.vta: 1  12

REF. 07122



- Material: 100% poliéster
- Cierre gancho

- Material: 100% polyester
- Hook closure



Capas

Capes

u.m.vta: 1  12 

Boho
Boho
[REF.07570](#)



NEW

Cachemire azul
Blue cashmere
[REF.07571](#)



Étnico
Ethnic
[REF.07572](#)

Globos
Balloons
[REF.07573](#)

Leopardo
Leopard
[REF.07574](#)



Piñas
Pineapples
[REF.07575](#)

- Material: 100% poliéster
- Cierre corchetes
- Repelente al agua

- Material: 100% polyester
- Hook fasteners
- Water repellent



Capas
Capes

u.m.vta: 1  12 

NEW

Leopardo
Leopard
REF.07746



07746

Zebra
Zebra
REF.07747



07747

Lunares
Moles
REF.07748



07748



07749

Geométrica
Geometric
REF.07749

Sombras
Shades
REF.07750



07750

Capa MISTERY

MISTERY cape

u.m.vta: 1	 12
------------	--



REF. 02506/50



- Material: plástico
- Cierre velcro
- Repelente al agua

- Material: plastic
- Closure velcro
- Water repellent

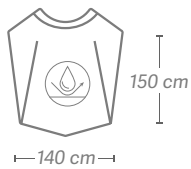

Capa FACES 2019

FACES 2019 cape

u.m.vta: 1	 12
------------	--

REF. 02501/73



- Material: poliéster
- Cierre velcro

- Material: polyester
- Closure velcro

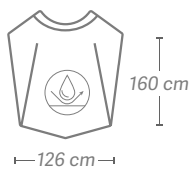

Capa LOOK
LOOK cape

u.m.vta: 1  12

- 
REF. 02504/75
- 
REF. 02504/50
- 
REF. 02504/68





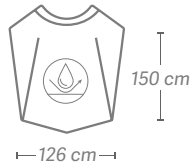

- Material: 100% poliéster
- Cierre corchetes
- Repelente al agua
- Libre de estática

- Material: 100% polyester
- Stud fasteners
- Water repellent
- Static-free



Capa NIGHT
NIGHT cape

u.m.vta: 1  12

- 
REF. 02503/50
- 
REF. 02503/58
- 
REF.02503/75
- 
REF. 02503/72
- 
REF. 02503/68
- 
REF. 02503/62
- 
REF. 02503/60

- Material: nylon
- Cierre botón

- Material: nylon
- Closure button

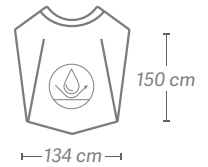

Capa SCISSORS

SCISSORS cape

u.m.vta: 1  12

REF. 01842/68



REF. 01842/59



REF. 01842/50



REF. 01842/73

- Material: 100% PVC
- Cierre velcro
- Repelente al agua

- Material: 100% PVC
- Cierre velcro
- Water repellent

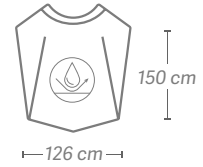

Capa MODEL

MODEL cape

u.m.vta: 1  60

REF. 04303/50

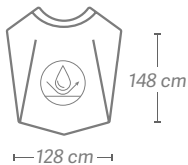

- Material: 100% poliéster
- Cierre velcro
- Repelente al agua

- Material: 100% polyester
- Closure velcro
- Water repellent



Capa BOB

BOB cape

u.m.vta: 1  :12

REF. 02632/59

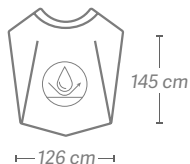

- Material: poliéster
- Cierre botones
- Repelente al agua

- Material: polyester
- Closure button
- Water repellent



Capa FACES 2000

FACES 2000 cape

u.m.vta: 1  12

REF. 01961/50

REF. 01961/59

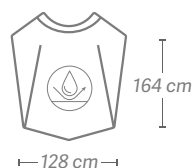

- Material: nylon
- Cierre velcro
- Repelente al agua

- Material: nylon
- Closure velcro
- Water repellent



Capa ANIMAL PRINT

ANIMAL PRINT cape

u.m.vta: 1  12



REF. 02502/58

- Material: nylon
- Cierre velcro

- Material: nylon
- Cierre velcro



REF. 02502/61

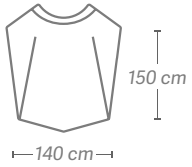

REF. 03522



REF. 03523

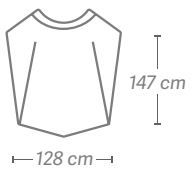

Capa ZEBRA

ZEBRA cape

u.m.vta: 1  12

REF. 03524



- Material: nylon
- Cierre velcro

- Material: nylon
- Cierre velcro

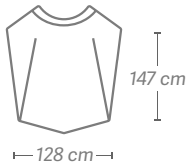

Capa EUROSTIL

EUROSTIL cape

u.m.vta: 1  12

REF. 04257/50

- Material: nylon
- Cierre botón
- Repelente al agua

- Material: nylon
- Cierre button
- Water repellent

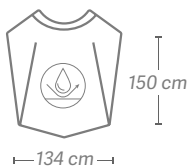

Capa BEAUTY

BEAUTY cape

u.m.vta: 1  12

REF. 04311

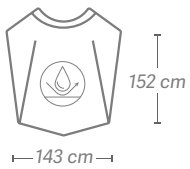

- Material: 100% poliéster
- Cierre velcro
- Repelente al agua

- Material: 100% polyester
- Closure velcro
- Water repellent



Capa de tinte PLACTON

PLACTON dye cape

u.m.vta: 1  12 



REF. 01988/73



REF. 01988/50



REF. 01988/59

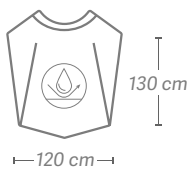

- Material: PVC
- Cierre velcro

- Material: PVC
- Closure velcro



Capa DAY
DAY cape

u.m.vta: 1  12



REF. 01077/58



REF. 01077/50



- Material: 65% poliéster
35% algodón
- Cierre velcro

- Material: 65% polyester
35% cotton
- Closure velcro

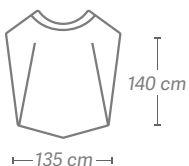

Capa ELEGANT
ELEGANT cape

u.m.vta: 1  50



REF. 01175/58



REF. 01175/60



REF. 01175/59



REF. 01175/50



REF. 01175/72

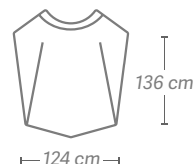



- Material: 100% poliéster
- Cierre velcro

- Material: 100% polyester
- Closure velcro



Capa BROSS
BROSS cape

u.m.vta: 1  10 

REF. 01228

- Material: plástico
- Cierre velcro
- Material: plastic
- Closure velcro

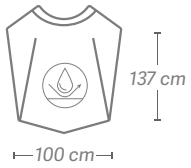

Capa LIGHTS
LIGHTS cape

u.m.vta: 1  5

-  REF. 04877/54
-  REF.04877/63
-  REF. 04877/68

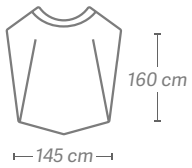

Capa STYLE

STYLE cape

u.m.vta: 1	 5
------------	---



REF. 04876/68



REF. 04876/58

- Material: nylon
- Cierre botón

- Material: nylon
- Closure button

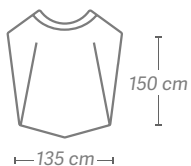

Capa WAISTLINE

WAISTLINE cape

u.m.vta: 1	 12
------------	--



REF. 01076/50

- Material: 65% poliéster, 35% algodón
- Cierre velcro
- Corte y tinte

- Material: 65% polyester, 35% cotton
- Closure velcro
- Cutting and dye

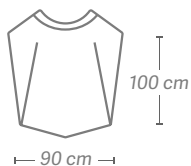

Bata negra

Black hairdressing gown

u.m.vta: 1	 12
------------	--

REF. 04301

- Material: 100% poliéster
- Cierre botón
- Material: 100% polyester
- Closure button



Hombro: 47 cm
Manga: 25 cm
Busto: 117 cm
Largo: 72 cm

Shoulder: 47 cm
Sleeve: 25 cm
Bust: 117 cm
Long: 72 cm



Kimono

Kimono

u.m.vta: 1	 12
------------	--

REF. 04300

- Material: 100% poliéster
- Cierre botón
- Material: 100% polyester
- Closure button





Hombro: 70 cm
Busto: 122 cm
Largo: 106 cm

Shoulder: 70 cm
Bust: 122 cm
Long: 106 cm



Delantal transparente
Transparent apron

u.m.vta: 1  12 

REF. 01929

- Material: PVC transparente
- Cierre lazo
- Ribete negro
- Repelente al agua

- Material: transparent PVC
- Closure tie
- Black trim
- Water repellent

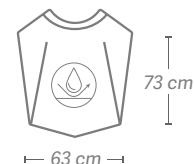

Delantal LONG
LONG apron

u.m.vta: 1  5

REF. 04880/50

- Material: 100% nylon
- Cierre lazo
- Repelente al agua
- Negro

- Material: 100% nylon
- Closure tie
- Water repellent
- Black

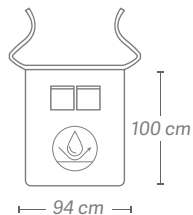

Delantal con bolsillo
Apron with pocket

u.m.vta: 1  12

REF. 04302

- Material: 100% poliéster
- Cierre lazo
- Repelente al agua

- Material: 100% polyester
- Closure tie
- Water repellent

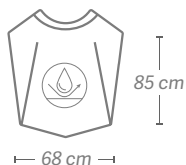

Delantal trabajo
Work apron

u.m.vta: 1  12

REF. 02510/50

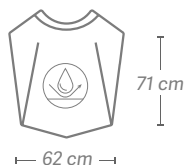

- Material: 24% poliuretano, 76% poliéster
- Cierre velcro
- Repelente al agua

- Material: 24% polyurethane, 76% polyester
- Closure velcro
- Water repellent



Capa infantil

Kids cape

u.m.vta: 1  12 

Coches

Cars

REF.07576



NEW

07576



07577



Dinosaurios

Dinosaur

REF.07577

07578



Koalas

Koala

REF.07578

07579



Marinera

Sailor

REF.07579

- Material: 100% poliéster
- Cierre corchetes
- Repelente al agua

- Material: 100% polyester
- Hook fasteners
- Water repellent



Capa infantil perros Kids cape with dogs

u.m.vta: 1	 12
------------	--



REF.02508/70



REF.02508/75



REF.02508/61



- Material: 100% poliéster
- Cierre velcro

- Material: 100% polyester
- Closure velcro

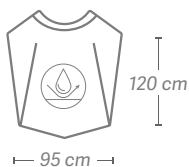

**Diseños muy divertidos en diferentes
estampados y colores**
**Fun designs in different patterns and
colours**

u.m.vta: 1	 12
------------	--



REF. 04313/68



REF. 04313/64

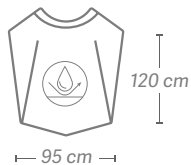

- Material: 100% poliéster
- Cierre velcro
- Repelente al agua

- Material: 100% polyester
- Closure velcro
- Water repellent

Vestuario profesional **Professional clothing**

*No disponible para Portugal
*Not available for Portugal

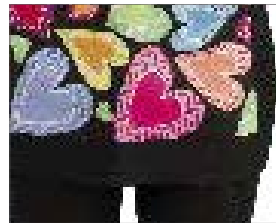
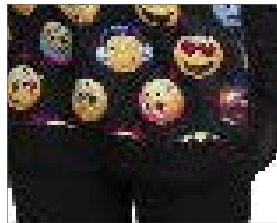



Casaca corazones
Hearts jacket

u.m.vta: 1 :40

S

98 -102 cm
102 - 106 cm
72 - 74 cm

REF.06297/50/1

M

106 -110 cm
108 - 112 cm
73 - 75 cm

REF.06297/50/2

L

114 -118 cm
116 - 120 cm
75 - 77 cm

REF.06297/50/3

XL

120 -124 cm
124 - 128 cm
77 - 79 cm

REF.06297/50/4

XXL

126 -130 cm
136 - 140 cm
78 - 80 cm

REF.06297/50/5

MOD. 51605128

Casaca manga mini con pinza de pecho y cuello mao. Contiene 1 bolsillo delantero, 1 bolsillo estampado y otro liso. Abrochada con botones de colores, prenda entallada con pinzas y con aberturas laterales. 100% poliéster.

Mini sleeve jacket with chest clip and mao collar. 1 front, 1 patterned pocket and a plain one. Buttoned with coloured buttons, fitted with tweezers and side slits. 100% polyester.

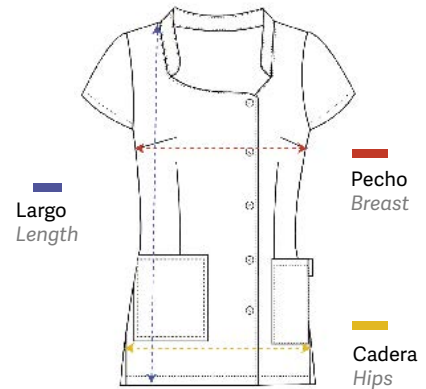

S

98 -102 cm
102 - 106 cm
72 - 74 cm

REF.06297/58/1

M

106 -110 cm
108 - 112 cm
73 - 75 cm

REF.06297/58/2

L

114 -118 cm
116 - 120 cm
75 - 77 cm

REF.06297/58/3

XL

120 -124 cm
124 - 128 cm
77 - 79 cm

REF.06297/58/4

XXL

126 -130 cm
136 - 140 cm
78 - 80 cm

REF.06297/58/5

MOD. 51605128

Casaca manga mini con pinza de pecho y cuello mao. Contiene 1 bolsillo delantero, 1 bolsillo estampado y otro liso. Abrochada con botones de colores, prenda entallada con pinzas y con aberturas laterales. 100% poliéster.

Mini sleeve jacket, with chest clip and mao collar. 1 front, 1 patterned pocket and a plain one. Buttoned with coloured buttons, fitted with tweezers and side slits. 100% polyester.

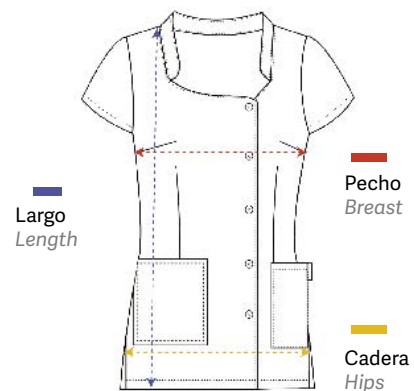

Casaca chica colores

Colourful girl jacket

u.m.vta: 1 40

M	L	XL	XXL
94-98 cm	102-106 cm	108-112 cm	118-122 cm
100-108cm	110-114 cm	120-124 cm	130-134 cm
71-73 cm	73-75 cm	74-76 cm	75-77 cm
REF.06296/50/2	REF.06296/50/3	REF.06296/50/4	REF.06296/50/5

MOD. 51505003

Casaca con pinza de pecho y espalda y escote cuadrado delantero. Estampado en diagonal con cremallera YKK, sisada y un bolsillo. Prenda entallada con pinzas y aberturas laterales. 100% poliéster.

Coat with chest and back clip and square front neckline. Diagonal stamped with YKK zip, sleeveless and a pocket. Garment fitted with clips and side openings. 100% polyester.



Casaca pintalabios cremallera

Zipper lipstick jacket

u.m.vta: 1 40

S	M	L	XL	XXL
88-92 cm	94-98 cm	102-106 cm	108-112 cm	118-122 cm
100-104 cm	100-108cm	110-114 cm	120-124 cm	130-134 cm
69-71 cm	71-73 cm	73-75 cm	74-76 cm	75-77 cm
REF.06299/50/1	REF.06299/50/2	REF.06299/50/3	REF.06299/50/4	REF.06299/50/5

MOD. 51308060

Casaca con pinza de pecho, espalda y escote cuadrado. 1 delantero estampado, cremallera YKK lateral, sisada y un bolsillo de vivo. Prenda entallada con pinzas y aberturas laterales.

Coat with chest and back clip and square neckline. Front diagonally stamped with YKK zip, sleeveless and a pocket. Garment fitted with clips and side openings.

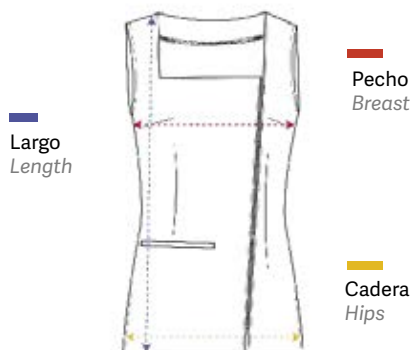



Casaca círculos de colores
Colours circles jacket

u.m.vta: 1 40

S	M	L	XL
88-92 cm	94-98 cm	102-106 cm	108-112 cm
100-104 cm	100-108cm	110-114 cm	120-124 cm
69-71 cm	71-73 cm	73-75 cm	74-76 cm
REF. 06304/50/1	REF. 06304/50/2	REF. 06304/50/3	REF. 06304/50/4

MOD. 51505005

Chaqueta básica sin mangas con tira estampada. Cierre con cremallera YKK al costado. Composición 100% poliéster. Dos bolsillos, uno en la cintura y otro en el pecho. Recomendada para comercios y centros de estética.

Basic sleeveless jacket with printed strip. YKK zip closure on the side. Composition 100% polyester. Two pockets, one at the waist and one on the chest. Recommended for shops and beauty centers.

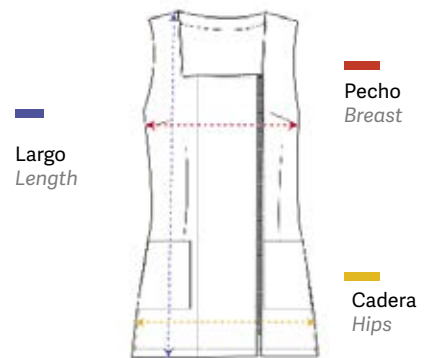

Casaca negra
Black jacket

u.m.vta: 1 40

S	M	L	XL	XXL
88-92 cm	94-98 cm	102-106 cm	108-112 cm	118-122 cm
100-104 cm	100-108cm	110-114 cm	120-124 cm	130-134 cm
69-71 cm	71-73 cm	73-75 cm	74-76 cm	75-77 cm
REF. 06556/50/1	REF. 06556/50/2	REF. 06556 /50/3	REF. 06556 /50/4	REF. 06556/50/5

MOD. 51605126

Chaqueta básica sin mangas con tira estampada. Cierre con cremallera YKK al costado. Composición 100% poliéster. Dos bolsillos, uno en la cintura y otro en el pecho. Recomendada para comercios y centros de estética.

Basic sleeveless jacket with printed strip. YKK zip closure on the side. Composition 100% polyester. Two pockets, one at the waist and one on the chest. Recommended for shops and beauty centers.

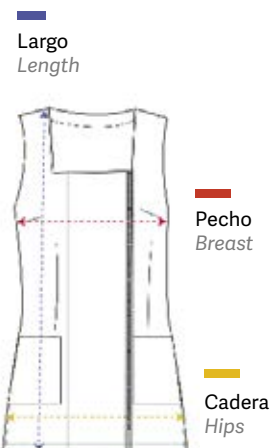

Casaca manga corta poliéster cremallera

Short sleeve polyester zipper jacket



u.m.vta: 1 40

XS	S	M	L	XL	2XL
86 cm	92 cm	98 cm	106 cm	114 cm	122 cm
92 cm	98 cm	104 cm	111 cm	119 cm	127 cm
71 cm	72 cm	73 cm	74 cm	76 cm	77 cm
82 cm	88 cm	93 cm	101 cm	109 cm	116 cm
REF.07146/1	REF.07146/2	REF.07146/3	REF.07146/4	REF.07146/5	REF.07146/6

MOD. 51308455N

Las medidas son aproximadas y pertenecen a la prenda acabada del contorno total. A la medida de la persona debe añadir entre 4 y 6 cm para la holgura.

The measurements are approximate and belong to the finished garment of the total contour. Tailored to the person should add between 4 and 6 cm for the slack.

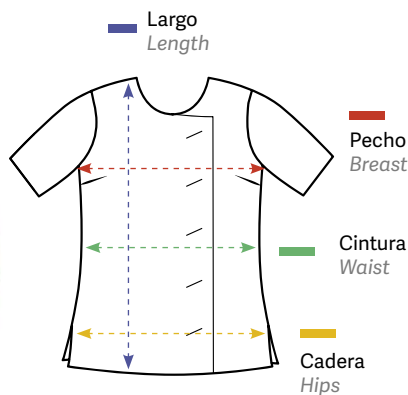

Casaca sin manga cara máscaras

Sleeveless jacket with face masks

u.m.vta: 1 40

XS	S	M	L	XL	2XL
90 cm	96 cm	102 cm	110 cm	118 cm	126 cm
98 cm	104 cm	110 cm	117 cm	125 cm	133 cm
71 cm	72 cm	73 cm	74 cm	76 cm	77 cm
83 cm	89 cm	95 cm	102 cm	110 cm	118 cm
REF.07145/1	REF.07145/2	REF.07145/3	REF.07145/4	REF.07145/5	REF.07145/6

MOD. 51805322

Las medidas son aproximadas y pertenecen a la prenda acabada del contorno total. A la medida de la persona debe añadir entre 4 y 6 cm para la holgura.

The measurements are approximate and belong to the finished garment of the total contour. Tailored to the person should add between 4 and 6 cm for the slack.

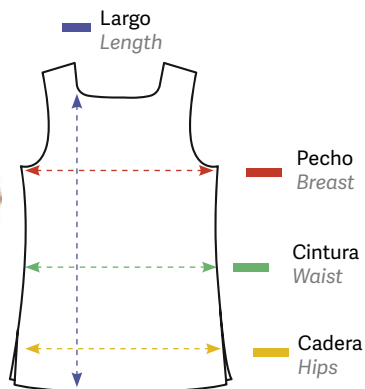

Estola chicas / corazones
Girls / hearts stole



u.m.vta: 1 :40

MOD. 21502006
 REF.06305/50

MOD. 21602109
 REF.06306/50

MOD. 21304421
 REF.06307/50

MOD. 21502001
 REF.06308/50

Estola ajustada con escote redondo y sisas pulidas con vivo de color. Delantero liso con bolsillo central divisorio estampado, bajos redondos y ajuste en la cintura con cintas que se cruzan por la espalda y se anudan en la cintura. 100% poliéster.

Tight stole with round neckline and polished armholes with vivid colour. Smooth front with stamped central divider pocket, round bottoms and waist adjustment with ribbons that cross at the back and are knotted at the waist. 100% polyester.

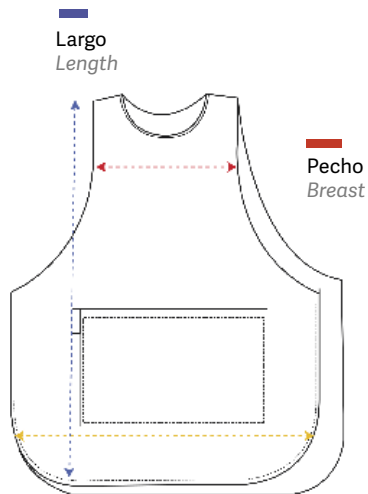

35 cm
 50 cm
 77 cm

Estolas estampadas

Printed stoles

u.m.vta: 1	 40
------------	--

MOD. 21902326

Estampado cara máscaras
Printed face masks

REF.07140**MOD. 21802219**

Multicorazones
Multi-hearted

REF.07144**MOD. 21902325**

Comic
Comic

REF.07141

Estola, prenda talla única, ajustada según necesidades. Medida estola A.
Stole, one size garment, adjusted according to needs. Stole measure A.

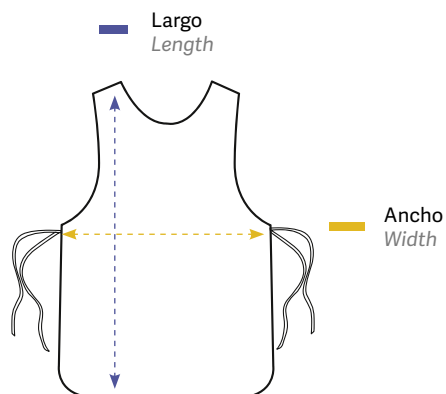

77 cm 
49 cm 

Estolas estampadas
Printed stoles

u.m.vta: 1 40

MOD. 21802218

Mechones
Strands of hair

REF.07143

MOD. 21802233

Pelo colores
Hair colours

REF.07142

MOD. 21802217

Laca uñas
Nail lacquer

REF.07148

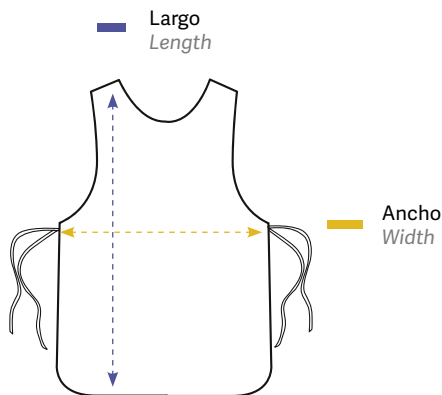

77 cm —
49 cm —

Estola 100% poliéster stretch 100% polyester stretch stole

u.m.vta: 1 40

Estola 100% poliéster stretch ajustada por la espalda con un lazo y con bolsillos delanteros grandes y cómodos. Ribeteada en rosa fucsia.

MOD. 21602124

100% polyester stretch stole adjusted at the back with a ribbon and with large and comfortable front pockets. Fuchsia pink trim.



35/36 cm
50/51 cm
77/78 cm

REF.06554/58



u.m.vta: 1 40

MOD. 21602124

100% poliéster
100% polyester



35/36 cm
50/51 cm
77/78 cm

REF.06554/50

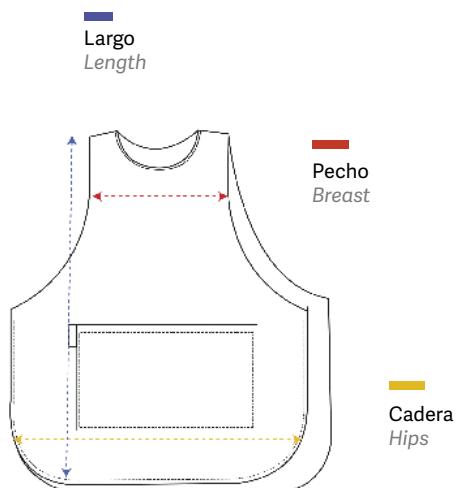

Delantal 100% poliéster stretch
100% polyester stretch apron

u.m.vta: 1 40

MOD. 31306075



Delantal 100% poliéster stretch ajustada por la espalda con un lazo y con bolsillos
 100% polyester stretch apron adjusted at the back with a ribbon and with pockets

67/68 cm
 79/180 cm

REF.06555



Cadera
Hips

Largo
Length



Estola cuello mao
Mao neck stole

u.m.vta: 1 40

MOD.21602130



Estola con cuello mao con corchetes metálicos a presión, mini manga y delantero con costadillos y bolsillos. Es ajustable con cintas que se cruzan por la espalda y se anudan en la cintura.

Mao stole with metal snap fasteners, mini sleeve and front with selvedges and pockets. Waist adjustment with ribbons that cross at the back and are knotted at the waist.

36/37 cm
 59/60 cm
 75/76 cm

REF.06309/50

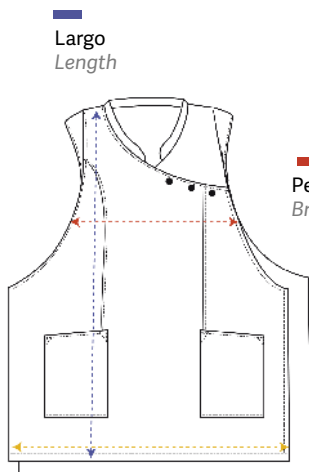

Largo
Length

Pecho
Breast

Cadere
Hips

100% poliéster
100% polyester



Estola 100% poliéster stretch
100% polyester stretch stole

u.m.vta: 1  40

lacla

MOD. 21304601
REF.06553/50

MOD. 21304601
REF.06553/58

MOD. 21304601
REF.06553/63

MOD. 21304601
REF.06553/68



Estola 100% poliéster stretch ajustada por la espalda con un lazo y con bolsillos delanteros grandes y cómodos
 100% polyester stretch stole adjusted at the back with a ribbon and with large and comfortable front pockets



Estola emoticonos
Emoticons stole

u.m.vta: 1 40

MOD. 21602143

36 cm
 51 cm
 78 cm



Estola ajustada con escote redondo. Delantero liso con bolsillo central divisorio estampado, bajos redondos y ajuste en la cintura con cintas que se cruzan por la espalda y se anudan en la cintura. 100% poliéster

REF.06303/50

Adjustable stole with round neckline. Smooth front with printed central dividing pocket, round bottoms and waist adjustment with ribbons that cross at the back and are knotted at the waist. 100% polyester



KIMONO antiestático
Antiestatic KIMONO

u.m.vta: 1 40

MOD. 21300013

123 cm
 123 cm
 106 cm



Kimono cruzado con cinturón y manga 3/4 con mini bolsillo en la manga. Fácil de planchar. Antidecoloración. 100% poliéster marroquí

REF.06302/50

Kimono crossed with belt, 3/4 sleeve with mini pocket on the sleeve. Easy to iron. Anti-discoloration. 100% marroquine polyester

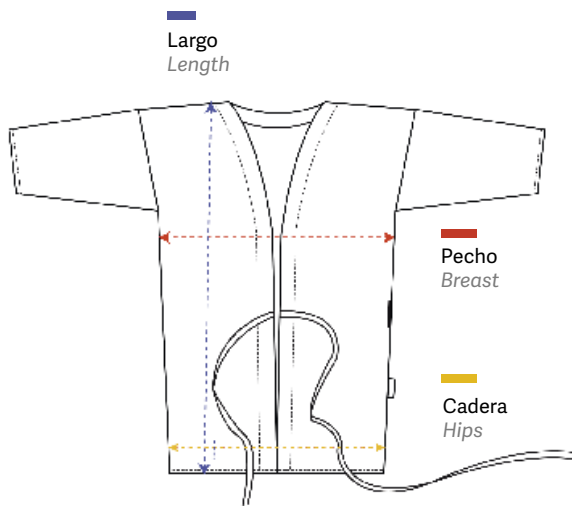

Pantalón mujer

Women pants

u.m.vta: 1 40

MOD. 41300011N

S

92-96 cm

92-96 cm

99-101 cm

REF.06312/50/1

M

98-102 cm

96-100 cm

101-103 cm

REF.06312/50/2

L

106-110 cm

106-110 cm

102-104 cm

REF.06312/50/3

XL

112-116 cm

114-118 cm

105-107 cm

REF.06312/50/4



Pantalón cintura media, goma trasera ajustado con 3 cordones.
• 100% poliéster

Mid-waist pants, rear rubber trim with 3 laces.
• 100% polyester



Pantalón mujer

Women pants

u.m.vta: 1 40

MOD. 41300011B

S

92-96 cm

92-96 cm

99-101 cm

REF.06312/58/1

M

98-102 cm

96-100 cm

101-103 cm

REF.06312/58/2

L

106-110 cm

106-110 cm

102-104 cm

REF.06312/58/3

XL

112-116 cm

114-118 cm

105-107 cm

REF.06312/58/4

• 67% poliéster
• 33% algodón

• 67% polyester
• 33% cotton

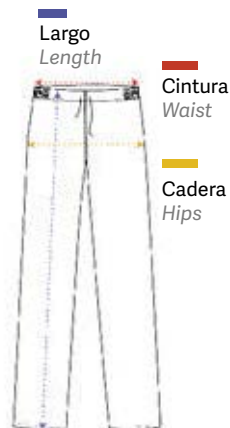



Pantalón mujer
Women pants

u.m.vta: 1 40

MOD. 41300901

36	38	40	42	44
74-78 cm	78-82 cm	82-86 cm	88-92 cm	92-96 cm
90-94 cm	94-98 cm	96-100 cm	98-102 cm	100-104 cm
100-102 cm	100-102 cm	101-103 cm	103-105 cm	105-107 cm
REF. 06311/50/1	REF. 06311/50/2	REF. 06311/50/3	REF. 06311/50/4	REF. 06311/50/5

Pantalón bielástico, bajo cintura, 2 bolsillos laterales. Ajustado al cuerpo.

- 95% poliéster
- 5% elast-biel

Bielastic pants, low waist, 2 side pockets. Fitted to the body.

- 95% polyester
- 5% elast-biel

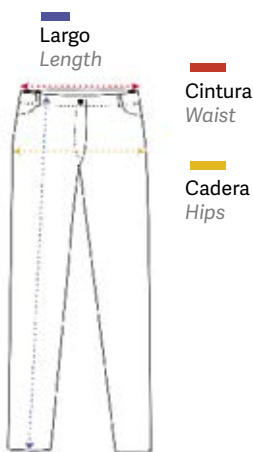

Pantalón unisex
Unisex pants

u.m.vta: 1 40

MOD. 41300904

S	M	L	XL
92-96 cm	98-102 cm	106-110 cm	112-116 cm
92-96 cm	96-100 cm	106-110 cm	114-118 cm
99-101 cm	101-103 cm	102-104 cm	105-107 cm
REF.06356/1	REF.06356/2	REF.06356/3	REF.06356/4

Pantalón 100% poliéster fino con 3 bolsillos. Ajustable a cintura con cordón. Fácil de planchar. Antideco y antiestático.

100% fine polyester pants with 3 pockets. Adjustable waist with drawstring. Easy to iron. Antideco and antistatic.

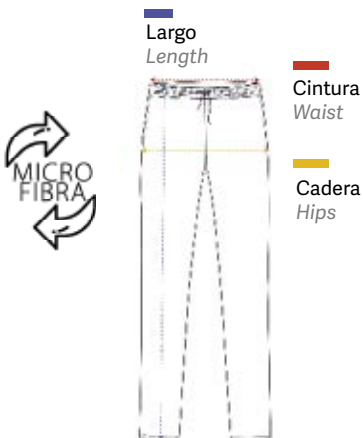



03

Cosmética capilar Hair cosmetics



*Champús, mascarillas, tintes,
decolorantes, oxigenadas...*

*Shampoos, hair masks, hair dyes,
bleaching, oxidant creams...*

Tintes Bright Colour de Tassel

Bright Colour dyes by Tassel



u.m.vta: 3  36 

100 ml

100% cobertura y durabilidad
Da brillo y protección
95 colores intensos
100% coverage and durability
Provides shine and protection
95 intense colours

Queratina
Ceras vegetales
Aceite de argán
Keratin
Vegetable waxes
Argan oil



Tinte en crema de oxidación enriquecido con aceite de argán, queratina y ceras vegetales que ayudan a fijar el color proporcionando a su vez brillo y protección al cabello. Crema de textura suave. Por su composición trata el cabello cuidándolo, protegiéndolo y formando una barrera protectora para no dañar la estructura capilar. Durabilidad en el color y máxima cobertura. Amplia gama de colores que cubren las necesidades de mercado.

- Elaborados con aceite de argán, queratina y ceras vegetales que ayudan a fijar el color, proporcionando a su vez brillo y protección al cabello
- Colores surtidos mínimo de 3 unidades por color
- Cajas de 36 unidades

Oxidation cream dye enriched with argan oil, keratin and vegetable waxes that help set the colour while providing shine and protecting the hair. Soft textured cream. Due to its composition, it protects the hair forming a protective barrier so as not to damage the hair structure. Colour durability and maximum coverage with a wide range of colours to meet market needs.

- *Made with argan oil, keratin and vegetable waxes that help the colour to set, providing the hair with shine and protection*
- *Assorted colours minimum of 3 units each colour*
- *Boxes of 36 units*

5.14 *New* nordic **BRIGHT COLOUR**

Ref. 06460



10N ▼

Rubio super claro
Super light blond

Ref. 06461

Ref. 06469



10.3N ▼

Rubio super claro dorado
Super light blond golden

Ref. 06464

Ref. 06467



10.31N ▼

Rubio super claro dorado ceniza
Super light blond golden ash

Ref. 06462

Ref. 06468



10.32N ▼

Rubio super claro beige
Super light blond beige

Ref. 06463

Ref. 06465



9.13N ▼

Rubio muy claro ceniza dorado
Very light blond golden ash



9.21N ▼

Rubio muy claro beige
Very light beige blond



9.23N ▼

Rubio muy claro beige dorado
Very light golden beige blonde



8.21N ▼

Rubio claro beige ceniza
Light beige ash blonde



8.23N ▼

Rubio claro beige dorado
Light golden beige blonde

1.4

Super aclarantes · Super lightening

Ref. 03994



11.21 ▼

Rubio extra claro perla ceniza
Extra light blonde ash pearl

Ref. 03995



11.00 ▼

Rubio extra claro natural
Extra light natural blond

Ref. 04605



12 ▼

Rubio súper aclarante natural
Super blonde natural lightening

Ref. 04606



12.1 ▼

Rubio súper aclarante ceniza
Super blonde lightening ash

Ref. 04610



12.96 ▼

Rubio ceniza violeta
Ash blonde Violet

Ref. 04620



PLATA ▼

Plata superaclarante
Extra light blonde ash pearl

5

Tonos pastel · Pastel tones

Ref. 07146



PT 0.8 ▼

Rosa pastel
Pastel pink

Ref. 07150



PT 0.7 ▼

Lila pastel
Pastel lilac

Ref. 07151



PT 0.4 ▼

Melocotón
Peach rose

Ref. 07152











PT 0.1 ▼

Gris metálico
Metallic grey





Bases naturales · Natural base colours

1+1.5

Ref. 03954	Ref. 03955	Ref. 03956	Ref. 03957	Ref. 03958
				
10 ▼	9 ▼	8 ▼	7 ▼	6 ▼
Rubio super claro <i>Super light blond</i>	Rubio muy claro <i>Very light blond</i>	Rubio claro <i>Light blond</i>	Rubio medio <i>Medium blond</i>	Rubio oscuro <i>Dark blond</i>
Ref. 03959	Ref. 03960	Ref. 03961	Ref. 03962	Ref. 03963
				
5 ▼	4 ▼	3 ▼	2 ▼	1 ▼
Castaño claro <i>Light chesnut</i>	Castaño medio <i>Medium chesnut</i>	Castaño oscuro <i>Dark chesnut</i>	Moreno <i>Brown</i>	Negro <i>Black</i>



Bases frías · Cool base colours

1+1.5

Ref. 03964	Ref. 03965	Ref. 03966	Ref. 03967
			
9.01 ▼	8.01 ▼	7.01 ▼	6.01 ▼
Rubio muy claro frío <i>Very light cool blonde</i>	Rubio claro frío <i>Cool light blonde</i>	Rubio medio frío <i>Cool medium blonde</i>	Rubio oscuro frío <i>Cool dark blond</i>



Violines · Violets

1+1.5

Ref. 03968	Ref. 03969	Ref. 04139
		
7.88 ▼	4.20 ▼	1.20 ▼
Púrpura ardiente <i>Fiery purple</i>	Castaño medio violeta <i>Medium chesnut violet</i>	Negro mora <i>Violet black</i>

Caobas · Dark auburn

1+1.5

Ref. 03967	Ref. 03968
	
6.54 ▼	5.5 ▼
Rubio oscuro caoba cobrizo <i>Dark blonde coppery mahogany</i>	Castaño claro caoba <i>Light auburn</i>

Dorados · Goldens

1-1.5

Ref. 03972



8.34 ▼

Rubio claro dorado cobre
Golden copper light blond

Ref. 03973



9.3 ▼

Rubio muy claro dorado
Very light golden blonde

Ref. 03874



8.3 ▼

Rubio claro dorado
Golden light blonde

Ref. 03975



7.3 ▼

Rubio medio dorado
Medium golden blonde

Ref. 03976



6.3 ▼

Rubio oscuro dorado
Dark golden blond

Ref. 03977



5.3 ▼

Castaño claro dorado
Light golden chesnut

Ref. 04603



5.35 ▼

Castaño claro dorado caoba
Light golden mahogany chesnut

Ref. 04609



7.31 ▼

Rubio medio dorado frío
Cool medium golden blonde

Ref. 04340



8.31 ▼

Rubio claro dorado ceniza
Light golden ash blonde

Ref. 04604



7.35 ▼

Rubio medio dorado caoba
Medium golden mahogany blonde

Cenizas · Ashes

1-1.5

Ref. 03968



8.1 ▼

Rubio claro ceniza
Light ash blonde

Ref. 03969



7.1 ▼

Rubio medio ceniza
Medium ash blonde

Ref. 03970



6.1 ▼

Rubio oscuro ceniza
Dark ash blonde

Ref. 03971



5.1 ▼

Castaño claro ceniza
Light ash chesnut

Ref. 04338



1.1 ▼

Negro azulado
Blue black

Ref. 04343



10.1 ▼

Rubio platino ceniza
Ash platinum blonde

Ref. 04870



PLATA ▼

Plata intenso ceniza
Ash intense silver

Beige · Beige

1-1.5

Ref. 03978



9.32 ▼

Rubio muy claro beige
Very light beige blonde

Ref. 03979



8.32 ▼

Rubio claro beige
Light beige blonde

Ref. 03980



7.32 ▼

Rubio medio beige
Medium beige blond

Marrones · Browns

1-3,5

Ref. 04818



8.77 ▼

Rubio claro chocolate
Light chocolate blonde

Ref. 07951



7.77 ▼

Rubio medio chocolate
Medium chocolate blonde

Ref. 04808



6.77 ▼

Rubio oscuro marrón medio
Medium brown dark blonde

Ref. 01882



5.77 ▼

Marrón chocolate
Chocolate brown

Ref. 04807



4.77 ▼

Castaño medio chocolate
Medium chocolate chesnut

Ref. 04817



8.7 ▼

Rubio claro marrón
Light brown blonde

Ref. 04815



7.7 ▼

Rubio medio marrón
Medium brown blonde

Ref. 04813



6.7 ▼

Rubio oscuro marrón
Dark brown blonde

Ref. 04812



5.7 ▼

Castaño claro marrón
Light brown chesnut

Ref. 04816



7.71 ▼

Rubio medio marrón frío
Cool medium brown blonde

Ref. 04814



6.71 ▼

Rubio oscuro marrón frío
Cool dark brown blonde

Ref. 07953



7.73 ▼

Rubio medio avellana
Medium hazelnut blonde

Ref. 07954



6.73 ▼

Marrón avellana
Hazelnut brown

COLOR
PROFESIONAL
PROFESSIONAL COLOUR

ACEITE
DE ARGÁN
ARGAN OIL



Matizadores · Toners

4-5,5

Ref. 06454



Amarillo
Yellow

Ref. 06482



Rojo
Red

Ref. 06485



Violeta
Violet

Ref. 06483

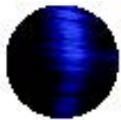

Azul
Blue

Ref. 06481



00 ▼

Base blanca mezcla
White mixture base

Rojos · Reds

1+1,5



Ref. 04348



5.6 ▼

Castaño claro rojo
Ligth red chesnut

Ref. 04341



6.6 ▼

Rubio oscuro rojo
Dark red blonde

Ref. 03985



6.64 ▼

Rubio oscuro rojo
cobre
*Dark copper
red blonde*

Ref. 03986



7.63 ▼

Picota
Cherry Red

Ref. 06470



7.62 ▼

Rubio medio
rojo cereza
*Medium cherry
blonde*

Ref. 0480



8.66 ▼

Rubio claro
rojo fuego
Ligth fiery blonde

Cobres · Coopers

1+1,5



Ref. 07099



8.44 ▼

Rubio claro
rojo fuego
*Light blonde
fire*

Ref. 03889



7.44 ▼

Rubio medio
cobre intenso
*Intense medium
copper blonde*

Ref. 03998



7.43 ▼

Rubio medio
cobre dorado
*Medium golden
copper blonde*

Ref. 03991



7.4 ▼

Rubio medio cobre
*Medium copper
blonde*

Ref. 01992



6.44 ▼

Rubio oscuro
cobre intenso
*Dark intense
copper blonde*

Ref. 03993



6.4 ▼

Rubio oscuro cobre
Dark cooper blonde



**CERAS
VEGETALES
VEGETABLE
WAXES**

Carta de tintes de colores con mechas
Hair dyes colours chart with strands

u.m.vta: 1  20

REF.04581/4





Fresh Colour free ammonia

Fresh Colour free ammonia

Sin Amoniaco

Ammonia free

u.m.vta: 3  36 

FRESH COLOUR FREE AMMONIA es la nueva tintura capilar sin amoniaco de 100 ml de Tassel Professional Hair Cosmetics, con una gama de 26 tonos. Enriquecida con OLEO PLUS, activos naturales con múltiples beneficios para el cabello.

- Efecto nutritivo del cabello
- Coloración gradual y uniforme
- Protege estructura capilar
- Protege el color de los rayos UV

FRESH COLOR FREE AMMONIA is the new ammonia-free hair dye 100 ml from Tassel Professional Hair Cosmetics, with a range of 26 shades. Enriched with OLEO PLUS, natural active ingredients with multiple benefits for the hair.

- Nourishing effect of the hair
- Gradual and uniform coloring
- Protects capillary structure
- Protects the color from UV rays

NEW



Negro
Black

Nº 1
REF.07662

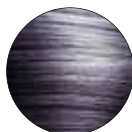

Castaño Oscuro
Dark brown

Nº 3
REF.07663



Castaño medio
Medium brown

Nº 4
REF.07664



Castaño claro
Light brown

Nº 5
REF.07665



Rubio oscuro
Dark blonde

Nº 6
REF.07666

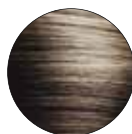

Rubio Medio
Medium blonde

Nº 7
REF.07667



Rubio claro
Light blonde

Nº 8
REF.07668



Rubio extra claro
Extra light blonde

Nº 9
REF.07669



Rubio extra claro intenso
Extra blonde clear intense

Nº 10
REF.07670



Rubio oscuro ceniza
Dark blonde ash

Nº 6.1
REF.07671



Rubio claro ceniza
Light blonde ash

Nº 8.1
REF.07672



Rubio medio dorado
Medium golden blonde

Nº 7.3
REF.07675



Rubio extra claro dorado
Extra light golden blonde

Nº 9.3
REF.07676



Rubio extra claro
Extra light blonde

Nº 9.32
REF.07678



Rubio oscuro chocolate
Dark chocolate blonde

Nº 6.70
REF.07680



Rubio oscuro marrón
Dark blond brown

Nº 6.77
REF.07683

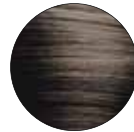

Rubio medio marrón irisado
Medium Iridescent Brown Blonde

Nº 7.72
REF.07689



Rubio oscuro cobre intenso
Intense dark copper blonde

Nº 6.44
REF.07694

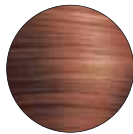

Rubio claro cobre intenso
Intense light copper blonde

Nº 8.44
REF.07695

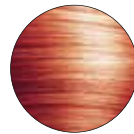

Rubio oscuro rojo intenso
Intense red dark Blonde

Nº 6.6
REF.07697



Rubio medio violeta
Medium violet blonde

Nº 7.88
REF.07699

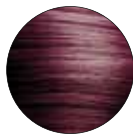

Rubio súper aclarante intenso
Intense super lightening blonde

Nº 12.0S
REF.07700



Rubio súper aclarante ceniza
Super lightening ash blonde

Nº 12.1S
REF.07701



Rubio súper aclarante irisado
Super lightening iridescent blonde

Nº 12.2S
REF.07702



Rubio súper aclarante dorado
Super lightening golden blonde

Nº 12.3S
REF.07703



Rubio extra claro beige irisado
Extra light iridescent beige blonde

Nº 9.31
REF.07788



Mascarilla nutritiva y reparadora de color

Nourishing and repairing colour mask

u.m.vta: 1  12

Neutro
Neutral

REF.07584

Rubio Perla
Pearl blonde

REF.07585

Gris
Grey

REF.07586

Rubio Hielo
Ice blonde

REF.07587

Chocolate
Chocolat

REF.07588

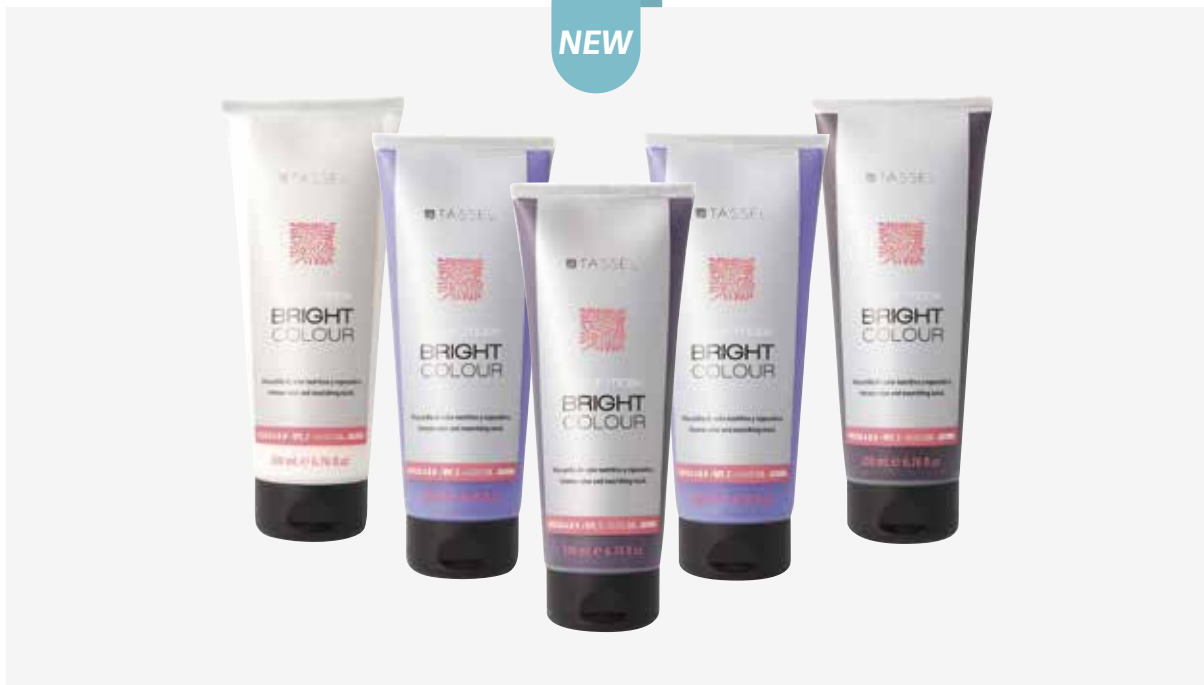

Proporciona colores intensos, vivos y duraderos que desaparecen con los lavados. Rico en ácidos grasos omega 6 y omega 9, fitoesteroles, vitamina E; aceite de oliva y jojoba.

APLICACIÓN:

1. Aplicar sobre cabello lavado y secado con toalla, aplicar mecha por mecha con la ayuda de pincel o con las manos repartir como una mascarilla normal
2. Dejar actuar un mínimo de 5 minutos. Para + intensidad de color, dejar + tiempo de exposición. Sin límite de tiempo
3. Aclarar con abundante agua templada

Consejos:

- No se debe aplicar champú una vez aclarado el producto
- No es necesario dejar tiempo de margen entre aplicaciones

Provides intense, vivid and long-lasting colours that fade with washing. Rich in omega 6 and omega 9 fatty acids, phytosterols, vitamin E; olive and jojoba oil.

APPLICATION:

1. Apply to washed and towel-dried hair strand by strand with a brush or your hands like you would a normal mask
2. Leave in for at least 5 minutes. For more colour intensity, allow more exposure time. No time limit
3. Rinse with plenty of lukewarm water

Tips:

- Do not shampoo after rinsing the product
- No need to leave time between applications

Rosa
Pink

REF.07589

Cobre
Copper

REF.07590

Rojo
Red

REF.07591

Rojo violeta
Red violet

REF.07592

Violeta
Violet

REF.07593



u.m.vta: 1  100

REF.07613





Oxy BRIGHT Cream

Gracias a su textura cremosa y a sus componentes de extractos vegetales y aceites naturales es más fácil de emulsionar y de extender sobre el cabello, siendo a su vez mucho más respetuosa con la fibra capilar, dejando el cabello suave y tratado.

Its creamy texture and its ingredients (vegetable extracts and natural oils) make it easier to emulsify and apply to the hair, being in turn much more respectful with the hair fiber, leaving the hair soft and treated.

Crema oxidante 10 vol. Oxidant cream 10 vol.

u.m.vta: 1  12 

150 ml

REF. 04336

u.m.vta: 1  12  u.m.vta: 1  2

1 L









5 L

REF. 04337

REF.04438



Crema oxidante 20 vol.
Oxidant cream 20 vol.



u.m.vta: 1  72 	u.m.vta: 1  114 	u.m.vta: 1  12 	u.m.vta: 1  12 	u.m.vta: 1  2
75 ml	75 ml	150 ml	1 L	5 L
REF. 07464	REF. 07160	REF. 04209	REF. 04067	REF.04439



Oxidante en crema. Su fórmula estabilizada consigue una mezcla cremosa y suave con los tintes y la decoloración, obteniendo como resultado unos colores perfectos, homogéneos y de fácil aplicación. Ideal para el tinte Bright Colour de Tassel. Perfecto para realizar una aplicación, monodosis.



Cream oxidant. Its stabilized formula achieves a creamy and smooth mix with dyes and bleaching, resulting in perfect, homogeneous and easy-to-apply colors. Ideal for Tassel Bright Colour hair dye. Perfect for making an application, monodose.

Crema oxidante 30 vol.
Oxidant cream 30 vol.

u.m.vta: 1  12 

150 ml

REF. 04210

u.m.vta: 1  12 

u.m.vta: 1  2

1 L

5 L

REF. 04068

REF.04440





Crema oxidante 40 vol.
Oxidant cream 40 vol.

u.m.vta: 1  12 

150 ml

REF. 04211

Perfume manzana
 Apple fragrance

u.m.vta: 1  12 

u.m.vta: 1  2

1 L



5 L

REF. 04069

REF.04440



Oxidante en crema azul
Hair oxidant blue cream

u.m.vta: 1  6 

10 vol

REF. 07792

20 vol

REF. 07793

30 vol

REF. 07794

40 vol

REF. 07795

1 L



La innovadora fórmula de OXY BRIGHT BLUE de textura ligera y fluida, está especialmente indicada para las tinciones rubias (a partir de la altura 8) y decoloraciones. Elimina el efecto amarillo y naranja manteniendo el color natural sin reflejos no deseados.

An innovative formula of OXY BRIGHT BLUE, both light and fluid, especially indicated for blondes (from 8 onwards) and bleaching. Eliminates the yellow or orange effect while maintaining the natural colour without unwanted reflections.

Caja de tintura de 6 colores fantasía

Dyeing box with 6 fantasy colours

u.m.vta: 1  1

100 ml

REF.04611

No necesita oxidante
Does not need oxidant

- Suave e hidratante
- Soft and moisturizing



Caja de tintura de 6 colores fantasía. Se aplican directamente sobre el cabello. Descubre todas las combinaciones que puedes hacer tan solo mezclando cualquiera de nuestros colores con el blanco, obteniendo así una amplia gama de tonos pastel. Además, puedes combinarlos entre sí. Para añadir un toque de fantasía, también puedes mezclarlos con el tinte Bright Colour.

Dyeing box 6 fantasy colours. It is applied directly on the hair. Discover all the combinations you can do just by mixing any of our colours with white. You will get a wide range of pastel colours, you can combine them with each other. To add a touch of fantasy, you can also mix them with the Bright Colour dye.

u.m.vta: 1  6

B-0

REF. 04442



B-3

REF. 04447



B-5

REF. 04444



B-6

REF. 04446



B-7

REF. 04445



B-8

REF. 04443

*Solo apto para mezclas y disoluciones · Only suitable for mixtures and solutions

Dye Protect

Dye Protect

u.m.vta: 1  24 

200 ml

REF.07479

Colour cleaner

Colour cleaner

u.m.vta: 1  24 

200 ml

REF.07480



Fluido protector para las manchas de la coloración. Fluido suave e hidratante que protege la piel de las manchas de la coloración evitando las posibles irritaciones. Para evitar picores en la aplicación de la coloración puedes ponerle unas gotas en la mezcla de la tintura antes de su aplicación.

Protective fluid for colour stains. Soft and hydrating fluid that protects the skin from stains of coloration avoiding possible irritations. To avoid itching when applying the colour, you can put a few drops in the dye mixture before applying it.



Loción limpiadora de las manchas de la coloración. Elimina las manchas producidas por la coloración a la vez que cuida la piel gracias a las propiedades del aloe vera.

Cleaning lotion for colour stains. Eliminates stains caused by colouring while taking care of the skin thanks to the properties of aloe vera.



Sachet Dye Protect Dye Protect sachet

u.m.vta: 100  100

REF.07650

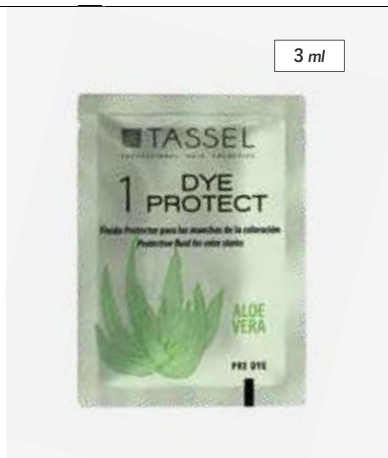

Sobre Colour cleaner Colour cleaner sachet

u.m.vta: 100  100

REF.07651

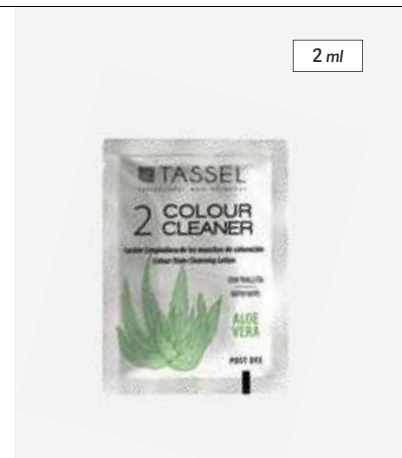

Kit tintura Dyeing kit

u.m.vta: 100  100

3 ml



REF.03998

- Sobre de aceite antimanchas
- + capa un solo uso
- + guantes

- Sample pouch of anti-stain oil
- + single-use layer
- + gloves





Polvo decolorante WILD BRIGHT
WILD BRIGHT bleaching powder

u.m.vta: 50  50 

25 g

REF. 04289

u.m.vta: 1  12 

500 g

REF.07548

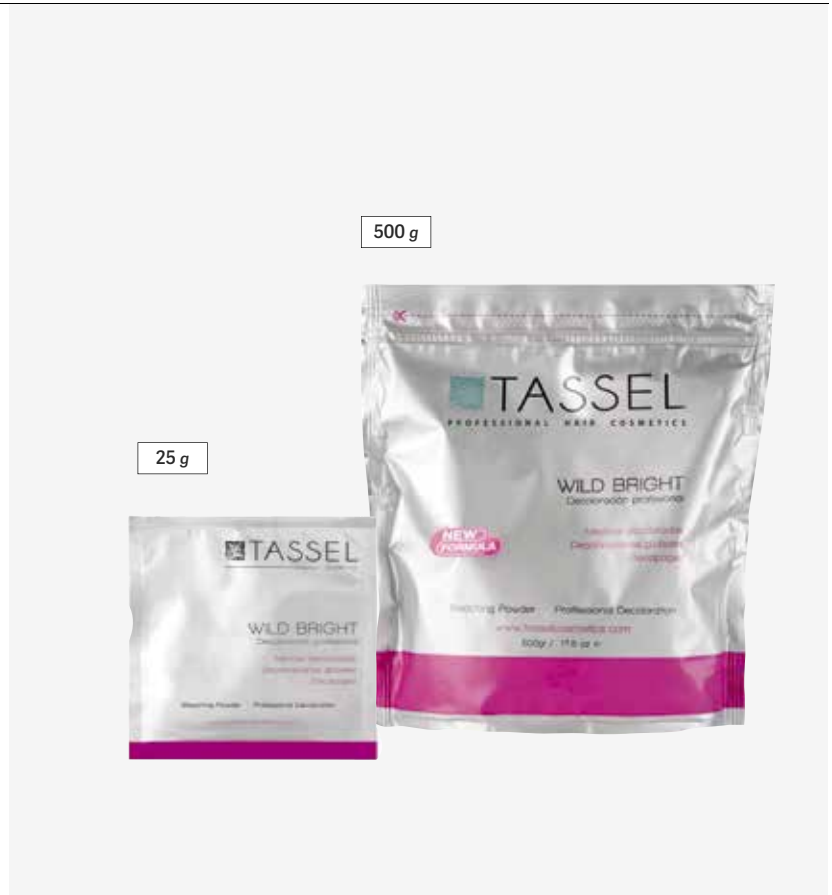



Con
autocierre
With
self-closing

Gran capacidad de arrastre del color siendo a su vez cuidadoso con el cabello. En dos prácticos formatos pequeño y grande, elige el que mejor se adapte a tus necesidades.



This product has a high colour removal capacity while remaining mild on the hair. It is available in two practical formats, small and large; you can choose the one that is best suited to your needs.

Polvo decolorante WILD WHITE
WILD WHITE bleaching powder

u.m.vta: 50  50 

25 g

REF.03611

u.m.vta: 1  12 

500 g

REF.07546



SCAN
ME!

Con
autocierre
With
self-closing

Sin
amoníaco
Ammonia
free





Aceite de Argán y queratina

Wild White tiene el mismo poder blanqueante que el decolorante Wild Bright, la única diferencia es que NO contiene amoníaco y protege la fibra capilar gracias al aceite de argán y la queratina. Puede utilizarse también para decoloraciones corporales y faciales utilizando oxidante de 10 vol.

Argan oil and keratin

Wild White has the same whitening power as the Wild Bright bleaching powder, the only difference being that it does NOT contain ammonia and it protects hair fibres thanks to the argan oil and keratin. It can also be used for bodily and facial discolorations using 10 vol. oxidant.

Decoloración Deco-plex bolsa 500g.
Deco-plex bleaching bag 500g.

u.m.vta: 50	 50		u.m.vta: 1	 12	
-------------	--	---	------------	--	---

25 g

REF. 07428

500 g

REF.07201



*Con
autocierre
With
self-closing*



Más protección en tus decoloraciones con la nueva DECO-PLEX, con Algas rojas & Aminoácidos que cuidan la estructura del cabello. Puede aclarar hasta 8-9 niveles

More protection for your bleaching with the new DECO-PLEX, formulated with red algae & amino acids that care for the hair structure. It can clarify up to 8-9 levels

Dry shampoo - champú seco en polvo
Dry shampoo - dry shampoo powder

u.m.vta: 1	 12	
------------	--	---

300 ml

REF.07130

*No necesita
agua
No water
needed*

 **SCAN ME!**

Más información
More information



Dry Shampoo es un champú en polvo que se aplica en spray. Aporta un volumen más pronunciado. Ayuda a que el cabello se mantenga limpio durante más tiempo. Ideal para cabellos grasos, absorbe el exceso de sebo, matificando el tallo del cabello aportando un aspecto más limpio y sano. También se recomienda para cabellos recién lavados, para texturizar, dar volumen y facilitar el peinado. Para todo tipo de cabello.

Dry Shampoo is a powder shampoo applied in spray form. It delivers a more pronounced volume. Helps hair stay clean for longer. Ideal for oily hair. It absorbs excess sebum, mattifying the hair shaft and providing a cleaner and healthier look. It is also recommended for freshly washed hair, to texturise, give volume and make combing easier. For all kinds of hair.

Botanical



ANTIAGE

u.m.vta: 1 12

500 ml

REF.07603

Champú
Shampoo

300 ml

REF.07604

Mascarilla
Mask

Calabaza y Acido Hialuronico Rejuvenecimiento Capilar

Previene el envejecimiento del cabello. Gracias al Ácido Hialurónico y Calabaza, que aporta al cabello un máximo de hidratación y reparación.

Pumpkin and Hyaluronic Acid Hair Rejuvenation

Prevents hair aging. Thanks to Hyaluronic Acid and Pumpkin, which provides the hair with maximum hydration and repair.

ANTIFRIZZ

u.m.vta: 1 12

500 ml

REF.07605

Champú
Shampoo

300 ml

REF.07606

Mascarilla
Mask

Aguacate y Aceite de Jojoba Elimina encrespamiento

Para cabellos rebeldes. La jojoba y el aguacate previenen la sequedad, electricidad estática y además reparan la fibra capilar

Avocado and Jojoba Oil Eliminates Frizz

For rebellious hair. Jojoba and avocado prevent dryness, static electricity and also repair the hair fiber.

NEW





ANTIAGE

300 ml



ANTI-FRIZZ

300 ml

SENSITIVEu.m.vta: 1  12 

500 ml

REF.07607 Champú
Shampoo



300 ml

REF.07608 Mascarilla
Mask**Sandia, Hinojo, Lúpulo, Melisa, Camomila, Muérdago, Achilea**
Calma irritaciones y suaviza el cuero cabelludo.

Para cuero cabelludo sensible o irritado. Sus extractos naturales calman y suavizan. Los cabellos mejoran su brillo natural y flexibilidad.

Watermelon, Fennel, Hops, Lemon Balm, Chamomile, Mistletoe, Achilea.
Soothes irritations and softens the scalp.

For sensitive or irritated scalp. Its natural extracts soothe and soften. The hair improves its natural shine and flexibility.

REPAIRu.m.vta: 1  12 

500 ml

REF.07609 Champú
Shampoo

300 ml

REF.07610 Mascarilla
Mask**Aceite de Coco, Cola de Caballo, Milenrama, Tomillo**
Repara, nutre e hidrata la cutícula en profundidad.

Reparador de cabellos secos o dañados. Sus principios activos naturales hidratan, reparan y reconstruyen la fibra capilar.

Coconut Oil, Horsetail, Yarrow, Thyme.**repairs, nourishes and hydrates the cuticle in depth.**

Repairing dry or damaged hair. Its natural active ingredients hydrate, repair and rebuild the hair fiber.

CONTROLu.m.vta: 1  12 

500 ml

REF.07611 Champú
Shampoo**Con Pomelo y Bardana.**
regula, controla y equilibra el cuero cabelludo.

Para cabellos grasos o con caspa. Enriquecido con extractos naturales que ayudan a regular las glándulas sebáceas y la descamación del cuero cabelludo.

Acción purificante: elimina bacterias y limpia el cuero cabelludo favoreciendo la eliminación de la caspa.

With Grapefruit and Burdock.**Regulates, controls and balances the scalp.**

Sulfate-free liquid soap for oily hair or hair with dandruff. Enriched with natural extracts that help regulate the sebaceous glands and flaking of the scalp.

Purifying action: eliminates bacteria and cleanses the scalp, favoring the elimination of dandruff.



500 ml

NEW**SENSITIVE**

300 ml



500 ml

REPAIR

300 ml



500 ml

CONTROL

Champú Hyaluronic

Hyaluronic shampoo

u.m.vta: 1  12 

1 L

REF.07379



SCAN
ME!

Más información
More information



Beneficios

- Limpieza suave
- Hidratación Profunda
- Reestructura el cabello

¿Qué es?

Enriquecido con ácido hialurónico. Efecto Anti-Aging. Limpieza suave e hidratación profunda del cabello. Reestructura el cabello dañado y quebradizo devolviéndole la elasticidad. Hidrata y suaviza el cabello.

Benefits



- Gentle cleaning
- Deep moisturising
- Restructures the hair

What is it?

It is enriched with hyaluronic acid. Anti-Ageing effect. Gentle cleansing and deep moisturising of the hair. Restructures damaged and brittle hair by restoring its elasticity. Moisturises and softens the hair.

Mascarilla Hyaluronic

Hyaluronic mask

u.m.vta: 1  12 

1 L

REF.07380



Beneficios

- Hidrata
- Suaviza
- Repara
- Previene la rotura del cabello

¿Qué es? Enriquecido con Ácido Hialurónico. Efecto Anti-Aging. Hidrata y suaviza el cabello. Aporta una hidratación intensa gracias al ácido hialurónico. Repara y previene la rotura y las puntas abiertas. Suaviza y flexibiliza el cabello.

Benefits

- Moisturises
- Softens
- Repairs
- Prevents hair breakage

What is it?

It is enriched with hyaluronic acid. Anti-Ageing effect. Moisturises and softens the hair. Hyaluronic acid provides intense moisture. Repairs and prevents breakage and split ends. Softens and structures the hair.

Caja 12 tratamientos Hyaluronic Splash (24 sobres x 15 ml)
Box of 12 Hyaluronic Splash treatments (24 sachets x 15 ml)

u.m.vta: 1  3 

REF.07438

12 tratamientos
15ml Fase1
+ 15ml Fase 2

12 treatments
15ml Phase1
+ 15ml Phase 2



ANTI-AGE CAPILAR. Mejora la calidad del cabello aportando una máxima hidratación, una sensación de relleno y elasticidad en el mismo. Evita el encrespamiento. Masajeando el producto sobre el cuero cabelludo, ayudas a estimular el folículo piloso enriqueciendo el mismo. Complementa con la línea de champú y mascarilla Hyaluronic.

Enriquecido con ácido hialurónico que, gracias a sus propiedades, mejora el cabello dándole una sensación de hidratación profunda, relleno y elasticidad y evitando el encrespado, aportando brillo y textura sedosa. Uniendo el aceite de argán con las proteínas de Seda y la queratina, forman un excelente Anti Age Capilar.

EXPLOSIÓN REPARADORA, ANTI AGE CAPILAR en sachet duplo:

- **ÁCIDO HIALURÓNICO:** mejora el cabello dándole una sensación de hidratación profunda, relleno y elasticidad evitando el encrespado, y aportando brillo y una textura sedosa.
- **KERATINA:** Aumenta la sedosidad del cabello lo que produce una hidratación profunda, intensifica el brillo y ayuda a sellar las puntas abiertas. Mantiene el color. Mejora la salud capilar.
- **PROTEÍNAS DE SEDA:** Hidratan en profundidad, revitalizan el cabello teñido y aportan brillo.
- **ACEITE DE ARGÁN:** Repara, reestructura el cabello dañado por agresiones externas, suaviza, nutre e hidrata.

CAPILLARY ANTI-AGEING. Improves the quality of the hair providing maximum hydration, a feeling of filling and elasticity in it. Avoid frizz. By massaging the product on the scalp, you help stimulate the hair follicle, enriching it. Complements with the Hyaluronic Shampoo and Mask Line.

Enriched with hyaluronic acid which, thanks to its properties, improves the hair giving it a feeling of deep hydration, filling and elasticity and avoiding frizz, providing shine and silky texture. Uniting the argan oil with the silk proteins and the keratin, they form an excellent Capillary Anti Age.

A REPAIRING EXPLOSION, ANTI-AGEING TREATMENT FOR HAIR in a sachet duplo:

- **HYALURONIC ACID:** improves the hair giving it a feeling of deep hydration, fullness and elasticity, avoiding frizz and giving it shine and a silky texture.
- **KERATINE:** increases the silkiness of the hair resulting in deep hydration, intensifies the shine and helps to seal split ends. Protects the colour. Improves hair health.
- **SILK PROTEINS:** They deeply hydrate, revitalize colored hair and add shine.
- **ARGAN OIL:** repairs, restructures hair damaged by external aggressions, softens, nourishes and moisturises.

Línea reestructurante de ARGÁN

ARGAN restructuring line

u.m.vta: 1	10	u.m.vta: 1	6	u.m.vta: 1	12
------------	----	------------	---	------------	----

500 ml

250 ml

50 ml

REF.07165

REF.07167

REF.07166

TASSEL crea la nueva línea argán, concebida para el tratamiento en profundidad de los cabellos. Reestructura la fibra capilar y devuelve al cabello un aspecto brillante y regenerado.

TASSEL creates the new argan line, conceived for the in-depth treatment of the hair. Restructures the hair fiber and gives the hair a shiny and regenerated appearance.

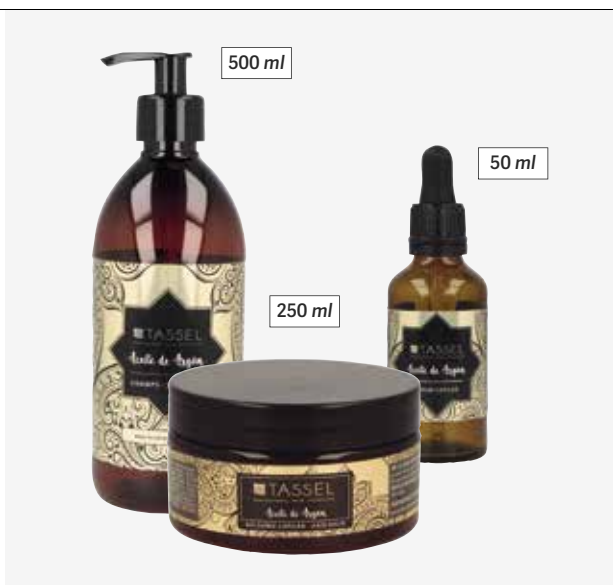

Champú

Shampoo

Ayuda en la regeneración del cabello y cuero cabelludo con un efecto positivo en el crecimiento del cabello. Hidrata y suaviza el encrespamiento. Aporta al cabello más cuerpo y brillo. Combate la fragilidad y la rotura.

Helps in hair and scalp regeneration with a positive effect on hair growth. Moisturizes and softens frizz. Gives hair more body and shine. Combat brittleness and breakage.

Bálsamo

Balm

Nutrición intensa desde la raíz hasta las puntas pasando incluso por el cuero cabelludo. Acondicionamiento profundo e hidratante. Reparación y restauración de la fibra capilar. Ideal para los cabellos secos y dañados.

Intense nutrition from the roots to the ends, even through the scalp. Deep conditioning and hydrating. Repair and restoration of the hair fiber. Ideal for dry and damaged hair.

Sérum

Serum

Repara y acondiciona el cabello. Elimina el encrespamiento al instante. Sérum fortalecedor, funciona de adentro hacia afuera para reparar el cabello dañado y roto.

Repairs and conditions hair. Eliminate frizz instantly. Strengthening serum, works from the inside out to repair damaged and broken hair.

Expositor capilar argán

Argan hair display

u.m.vta: 1

1

REF.07472

Expositor gratuito
Free display

Tratamiento aceite de argán

- Regeneración de la fibra capilar
- Repara y restaura la fibra capilar
- Hidrata, nutre y suaviza
- Elimina el encrespamiento

Argan oil treatment

- Regeneration of the hair fibre
- Repairs and restores hair fibre
- Moisturises, nourishes and softens
- Eliminates frizz





REF. 07165
(4 ud)

REF. 07167
(4 ud)

REF. 07166
(4 ud)

Champú para la prevención de la caída

Hair loss prevention shampoo

u.m.vta: 1  6u.m.vta: 1  12

400 ml

1 L

REF.03553

REF.03566



- Champú formulado específicamente para combatir la caída del cabello, ya que combina proteínas y bionutrientes de origen vegetal, que actúan como descongestivos y revitalizantes, evitando así la irritación
- Limpia en profundidad, eliminando las grasas que se forman en el cuero cabelludo dejando que el nuevo cabello se desarrolle sin impedimentos
- El cabello queda suave, brillante y sedoso

- *This shampoo has been specifically designed to combat hair loss, as it combines vegetable proteins and bio-nutrients with a decongestive and revitalising effect that help prevent irritation*
- *Cleanses in depth, eliminating any fat that builds up on the scalp, allowing new hair to develop freely*
- *Makes hair soft, shiny and silky*



Ampollas anticaída

Hair loss vials

u.m.vta: 1  6u.m.vta: 1  6

10 ml

10 ml

REF.03550

REF.03551

PACK prevención caída

- 12 ampollas (10 ml) prevención caída
- + champú prevención 400 ml

Hair loss prevention PACK

- 12 hair loss prevention vials (10 ml)
- + hair loss prevention shampoo 400 ml

- 12 ampollas (10 ml) prevención caída

- 12 hair loss prevention vials (10 ml)



Los mejores nutrientes para el cuero cabelludo son las proteínas de origen vegetal. Potencian la absorción de estos y favorecen la oxigenación del folículo piloso, disminuyendo así la caída del cabello. Los nutrientes vegetales también actúan como descongestivos y revitalizantes, evitando así la irritación. La queratina repara y fortalece el cabello, dándole volumen y brillo.

The best nutrients for the scalp are proteins of vegetable origin. They promote the absorption of nutrients and help oxygenate hair follicles, thus reducing hair loss. Vegetable nutrients also have a decongestive and revitalising effect that helps prevent irritation. Keratin repairs and strengthens hair, providing it with volume and shine.



NEUTRAL SHAMPOO

Nata



NEUTRAL SHAMPOO

Plátano



NEUTRAL SHAMPOO

Chocolate



NEUTRAL SHAMPOO

Lavanda



NEUTRAL SHAMPOO

Melón



NEUTRAL SHAMPOO

Fresa



NEUTRAL SHAMPOO

Coco

Línea
AROMA SENSATION
 AROMA SENSATION
line

Con el objetivo de cubrir las necesidades de mercado, TASSEL, con su carácter de innovación constante, lanza, amplía y renueva su línea de champús, cremas suavizantes y mascarillas. CHAMPÚ NEUTRO con agradable olor a NATA, CHOCOLATE, PLÁTANO, LAVANDA MELÓN, FRESA y COCO. Todos ellos formulados para conseguir un profundo lavado del cabello y cuero cabelludo. Su alta concentración de materia activa permite un perfecto lavado aportando al cabello más brillo y un aspecto más saludable. De uso diario. Ph 5,5.

In order to meet the needs of the market, TASSEL, with its character of constant innovation, launches, expands and renews its line of shampoos, smoothing creams and masks. NEUTRAL SHAMPOO with a pleasant scent of CREAM, CHOCOLATE, BANANA, LAVENDER MELON, STRAWBERRY and COCONUT. All formulated for a deep clean of the hair and scalp. Its high concentration of active ingredients allows a perfect washing. The hair becomes shinier and healthier. For daily use. Ph 5.5. The hair becomes shinier and healthier. For daily use. Ph 5.5.



Aroma Sensations Nata

Aroma Sensations Cream

u.m.vta: 1		6		u.m.vta: 1		2
------------	--	---	--	------------	--	---

1 L

Shampoo

REF.07629

5 L

Shampoo

REF.07628

u.m.vta: 1		5		u.m.vta: 1		2
------------	--	---	--	------------	--	---

Hair Mask

1 L

REF.07631

Smoothing Cream

5 L

REF.07630



Aroma Sensations Plátano
Aroma Sensations Banana

u.m.vta: 1		6		u.m.vta: 1		2
------------	---	---	---	------------	---	---

Shampoo

1 L

REF.07637

Shampoo

5 L

REF.07636

u.m.vta: 1		5		u.m.vta: 1		2
------------	---	---	---	------------	---	---

Hair Mask

1 L

REF.07639

Smoothing Cream

5 L

REF.07638



Aroma Sensations Chocolate
Aroma Sensations Chocolate

u.m.vta: 1		6		u.m.vta: 1		2
------------	---	---	---	------------	---	---

Shampoo

1 L

REF.07633

Shampoo

5 L

REF.07632

u.m.vta: 1		5		u.m.vta: 1		2
------------	---	---	---	------------	---	---

Hair Mask

1 L

REF.07635

Smoothing Cream

5 L

REF.07634



Aroma Sensations Lavanda
Aroma Sensations Lavander

u.m.vta: 1  6  u.m.vta: 1  2

Shampoo

1 L

REF.07641

Shampoo

5 L

REF.07640

u.m.vta: 1  5  u.m.vta: 1  2

Hair Mask

1 L

REF.07643

Smoothing Cream

5 L

REF.07642



Aroma Sensations Melón
Aroma Sensations Melon

u.m.vta: 1  6  u.m.vta: 1  2

Shampoo

1 L

REF.07199

Shampoo

5 L

REF.06337

u.m.vta: 1  5  u.m.vta: 1  2

Hair Mask

1 L

REF.06450

Smoothing Cream

5 L

REF.07798



Aroma Sensations Fresa
Aroma Sensations Strawberry

u.m.vta: 1  6 

u.m.vta: 1  2

Shampoo



Shampoo

1 L

5 L

REF.07200

REF.06338

u.m.vta: 1  5 

u.m.vta: 1  2

Hair Mask

Smoothing Cream

1 L



5 L

REF.06448

REF.07797



Aroma Sensations Coco
Aroma Sensations Coconut

u.m.vta: 1  6 

u.m.vta: 1  2

Shampoo

Shampoo

1 L

5 L

REF.07198

REF.06339

u.m.vta: 1  5 

u.m.vta: 1  2

Hair Mask

Smoothing Cream

1 L

5 L

REF.06449

REF.07796



Champú NEUTRO
NEUTRAL shampoo

u.m.vta: 1  12 u.m.vta: 1  2

1 L

REF.03556

5 L

REF.04325

Uso
frecuente
Frequent
use

Champú para todo tipo de cabello y especialmente indicado para el uso diario o frecuente. Lava el cabello de una forma suave y manteniendo el PH. Protege el cuero cabelludo, dándole equilibrio y salud al cabello.

This shampoo is suitable for all hair types and is recommended for daily or frequent use. It cleans the hair softly and maintaining its PH. It also protects the scalp, providing hair with balance and health.



Champú CLOROFILA
CHLOROPHYLL shampoo

u.m.vta: 1  2

5 L

REF.04324

Formulado para lavar suavemente, con frecuencia y en profundidad todo tipo de cabellos. Aporta al cabello más brillo, un aspecto más saludable y un agradable olor a menta.

It has been formulated to cleanse all hair types frequently and in depth. Provides additional shine, a healthier look and a pleasant mint smell.



Crema suavizante **HERBAL** HERBAL smoothing cream

u.m.vta: 1	 12	u.m.vta: 1	 2
------------	--	------------	---

1 L	5 L
-----	-----

REF.03555 REF.04326

Acondicionador de extractos vegetales que reparan, fortalecen y previenen la descamación de la fibra capilar. Estos extractos aportan al cabello suavidad, brillo y luminosidad, favoreciendo el peinado.

Conditioner with vegetable extracts that repairs, strengthens and prevents flaking in hair fibres. These extracts provide softness, shine and light to hair and make combing easier.



Champú **PROTECT COLOUR** PROTECT COLOUR shampoo

u.m.vta: 1	 500	u.m.vta: 1	 12
------------	---	------------	--

10 ml	1 L
-------	-----

REF.06806 REF.04620

Champú específico para cabellos teñidos o coloreados. Reaviva y retiene el color del cabello durante más tiempo, aportando un aspecto suave, brillante y luminoso. PH ácido.

Specific shampoo for dyed or coloured hair. Revives and maintains the colour of the hair for longer and provides with a soft, bright and light appearance. Acidic PH.



Champú NUTRICIÓN
NOURISHING shampoo

u.m.vta: 1  500

u.m.vta: 1  12



10 ml

1 L

REF.06804

REF.03552

Mascarilla Nutri-Repair 1 l.
Nutri-Repair mask 1 l.

u.m.vta: 1  5 

1 L

REF.07486

NEW



Champú con proteínas y bionutrientes de fácil absorción y rápida incorporación a la estructura capilar. Contiene queratina que nutre, repara y regenera la cutícula del cabello y disminuye la tendencia a formar puntas abiertas, protegiéndolo de las agresiones externas. El resultado es un cabello más fortalecido, con más volumen y más brillo.



Shampoo with proteins and bio-nutrients that are quick and easy to absorb and incorporate in the hair structure. It contains keratin, which nourishes, repairs and regenerates hair cuticles and curbs the tendency to form split ends, protecting it from external aggressions. The end result is a stronger hair with increased volume and shine.

La mascarilla Nutri-Repair nutre, repara y regenera intensamente la fibra capilar. Acondiciona el cabello aportándole brillo y suavidad, evitando así la electricidad estática. Indicada especialmente para cabellos normales y secos. Nueva fórmula & nuevo formato de 1 litro.

The Nutri-Repair mask intensely nourishes, repairs and regenerates the hair fiber. Conditions the hair giving it shine and softness, thus avoiding static electricity. Especially indicated for normal and dry hair. New formula & new 1 liter format.

Champú fortificante con biotina y queratina

Fortifying shampoo with biotine and keratine

u.m.vta: 1	 500	u.m.vta: 1	 12
10 ml		1 L	

REF.06805

REF.03663



Mascarilla fortificante

Fortifying hair mask

u.m.vta: 1	 6
500 ml	



REF.03674

Champú y mascarilla especialmente formulado con biotina (vitamina h) y queratina. La biotina evita la secreción sebácea y la caída del cabello, reactivando el crecimiento, dándole fuerza y grosor. La queratina nutre, repara y regenera la cutícula del cabello y disminuye la tendencia a formar puntas partidas. El resultado es un cabello más fortalecido, con más volumen y más brillo. PH 5.5.

A specially formulated shampoo and hair mask with biotin (vitamin h) and keratin. Biotin prevents oil secretion and hair loss and reactivates hair growth, providing hair with strength and thickness. Keratin nourishes, repairs and regenerates hair cuticles and curbs the tendency to form split ends. The result is that the hair is stronger, shinier and has more volume. PH 5.5.

Champú azul para cabellos rubios o blancos



Blue shampoo for blond or white hair

u.m.vta: 1	 600	u.m.vta: 1	 12
10 ml		500 ml	

REF.06659

REF.06563



u.m.vta: 1	 6	
1 L		



REF.07429

- Doble pigmentación violeta + azul
- Elimina naranjas y amarillos no deseados de rubios y/o cabellos platino o blancos
- Double pigmentation violet + blue
- Eliminates unwanted oranges and yellows from blondes and/or platinum or white hair

Champú azul específico para eliminar los reflejos amarillentos o anaranjados de los cabellos rubios, consiguiendo un rubio más metalizado y natural. A su vez, es ideal para tratar los cabellos blancos y canosos, ayuda a reducir los tonos amarillentos, potenciando así el color blanco del cabello y se recupera la suavidad y brillo natural del mismo.

Specific blue shampoo to eliminate yellowish or orange highlights of blond hair, getting more matt and natural blonde. At the same time, it is ideal for treating white and gray hair, it helps reduce yellowish tones, thus enhancing the white color of the hair and recovering its softness and natural shine.

Mascarilla capilar reparadora Bright Colour Bright Colour hair mask repair

u.m.vta: 1  12 

400 ml

REF.06313

Champú INTENSE BRIGHT COLOUR INTENSE BRIGHT COLOUR shampoo

u.m.vta: 1  2

5 L

REF.06336



Enriquecida con aceite de argán, queratina y colágeno que reestructuran y nutren el cabello seco y deshidratado ofreciendo brillo y suavidad. Repara los daños causados por agresiones térmicas y lo protege contra la rotura.



Enriched with argan oil, keratin and collagen that restructure and nourish dry and dehydrated hair offering shine and softness. It repairs the damages caused by thermal attacks and protects it against breakage.

CHAMPU INTENSE BRIGHT COLOUR es el complemento de la línea de productos técnicos de TASSEL, enriquecido con aceite de argán y queratina. Especialmente indicado para cabellos secos, teñidos, decolorados. Con propiedades hidratantes, reestructurantes y reparadoras de la fibra capilar. El complemento ideal a nuestra NUEVA MASCARILLA CAPILAR BRIGHT MASK enriquecida con aceite de argán y queratina, y formulada para que actúe como reparadora del cabello dañado.

The INTENSE BRIGHT COLOUR SHAMPOO supplements TASSEL's technical product range. Enriched with argan oil and keratin. Specially indicated for dry, dyed and bleached hair. With moisturising, restructuring and repairing properties of the hair fibre. The ideal complement to our repairing NEW BRIGHT HAIR MASK with argan oil and keratin.

Caja con 12 tratamientos Wow Effect

Box with 12 Wow Effect treatments

u.m.vta: 1  3 

12 tratamientos 15ml fase1
+ 15ml fase 2
12 treatments 15ml phase1
+ 15ml phase 2



Más
información
More
information

SCAN
ME!



REF.07244

**Explosión reparadora
para el cabello en 5 min**
A 5 min nourishing
explosion for the hair



Con queratina, aceite de argán y seda capilar

Tratamiento enriquecido con:

- **Queratina**, que aumenta la sedosidad del cabello que produce una hidratación profunda, intensifica el brillo y ayuda a sellar las puntas abiertas. Mantiene el color y mejora la salud capilar.
- **Proteínas de seda**, que hidratan en profundidad, revitalizan el cabello teñido y aportan brillo.
- **Aceite de argán**, repara, reestructura el cabello dañado por agresiones externas, suaviza, nutre e hidrata.

Sobre 1 **Efecto Flash** + sobre 2 **Efecto Impact**. Mezcla los 2 sobres y genera la **EXPLOSIÓN REPARADORA**. Recupera la salud de tu cabello en una sola aplicación.

MODO DE EMPLEO: Mezclar el contenido de ambos sobres en un bol no metálico hasta obtener una emulsión homogénea. Aplicar masajeando el cabello de raíz a puntas. Dejar actuar entre 5 y 10 minutos dependiendo del estado del cabello y aclarar con agua.

HIDRATA Y REESTRUCTURA LA FIBRA CAPILAR. Ideal para cabellos, teñido, decolorados, secos y quebradizos. Reestructura y repara la fibra capilar con efecto inmediato. Mantiene el color.

With keratin, argan oil and silk hair

Treatment enriched with:

- **Keratin**, which increases the silkiness of the hair resulting in deep hydration, intensifies shine and helps to seal split ends. Maintains colour and improves hair health.
- **Silk proteins**, which deeply hydrate, revitalize colored hair and add shine.
- **Argan oil**, which repairs, restructures hair damaged by external aggressions, softens, nourishes and moisturises.

Sachet 1 **Flash Effect** + Sachet 2 **Impact Effect**. Mix the 2 sachets and generate the **REMEDIAL EXPLOSION**. Recover the health of your hair in one application.

DIRECTIONS: Mix the contents of both sachets in a non-metallic bowl until you get a homogeneous emulsion. Apply by massaging into hair from root to tip. Leave on for 5 to 10 minutes depending on the state of the hair and rinse with water.

MOISTURIZES AND RESTRUCTURES THE CAPILLARY FIBER. Ideal for dyed, bleached, dry and brittle hair. Restructures and repairs the hair fiber with immediate effect. Keeps the colour.

Mascarilla nutrición con queratina
Keratine nourish mask

u.m.vta: 1  12

100 ml

REF.03435

u.m.vta: 1  6

500 ml

REF.06948

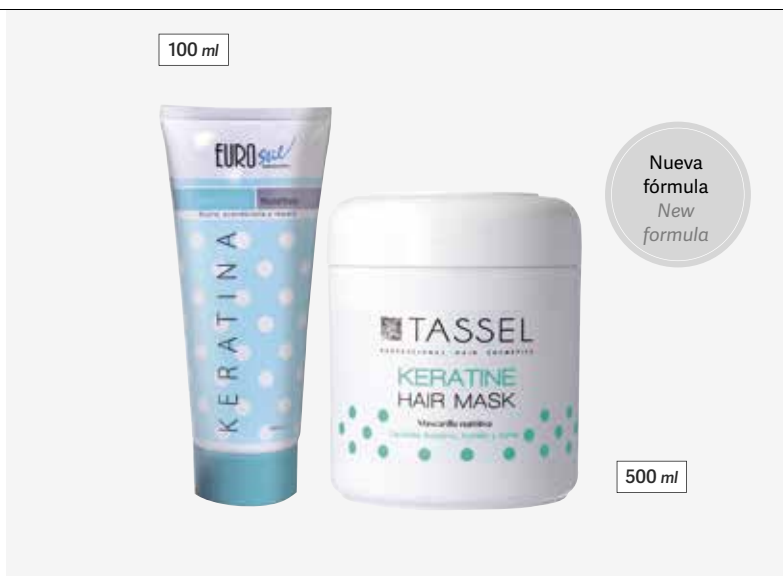

Formulada con queratina, que nutre, acondiciona y aumenta la elasticidad del cabello, reparándolo desde la raíz a las puntas, protegiéndolo de agresiones externas y disminuyendo la tendencia a formar puntas abiertas.

This formula contains keratin which nourishes, conditions and increases the elasticity of your hair, with a repairing effect from the root to the tips, protecting it from external aggressions and curbing the tendency to form split ends.

Kit playero queratina
Beach kit with keratin

u.m.vta: 1  6

REF.03519





Kit playero compuesto de protector solar capilar, mascarilla nutritiva, cepillo de madera de fuelle, peine plástico de púa ancha, pinza para recoger el cabello, pinzas de depilar las cejas y espejito doble con peine pequeño.

Beach kit that contains sunscreen for hair, a nourishing hair mask, a wooden cushioned hair brush, a broad-toothed plastic comb, a hair clamp, eyebrow tweezers and a double mirror with a small brush.

BI-PHASE TASSEL

BI-PHASE TASSEL

u.m.vta: 1  20 

500 ml

REF.07369

¿Qué es?

Enriquecido con lino que aporta al cabello hidratación, flexibilidad y suavidad, así como proteínas de trigo, que poseen efectos similares a la queratina. Hace que el cabello sea más elástico, con más volumen y actúa como un acondicionador natural. Específicamente para cabellos secos y dañados.

What is it?

It is enriched with flax that provides hydration, flexibility and softness to the hair, as well as wheat proteins, which have similar effects to keratin. It makes the hair more elastic, with more volume and acts as a natural conditioner. Specially designed for dry and damaged hair.

Beneficios

- Hidratación
- Flexibilidad
- Suavidad
- Aporta volumen y acondiciona

Benefits

- Moisture
- Flexibility
- Softness
- Provides volume and conditions



SCAN ME!

Más información
More information



Lovely Curls Tassel

Tassel Lovely Cursl

u.m.vta: 1  24 

250 ml

REF.07381

¿Qué es?

Crema acondicionadora que define los rizos. Contiene panthenol y proteínas de Trigo. Elimina el encrespamiento y aporta control de rizo. Máxima hidratación, volumen y movimiento a tu melena.

What is it?

A conditioning cream that defines the curls. It contains panthenol and wheat protein. Eliminates frizz and helps control curls. Maximum moisture, volume and movement to your hair.

Beneficios

- Control del rizo
- Máxima Hidratación
- Volumen
- Movimiento natural a tu melena

Benefits

- Curl control
- Maximum moisturising action
- Provides volume
- Natural movement to your hair





SCAN ME!

Más información
More information



Protector térmico
Thermal protector



u.m.vta: 1  12 

REF.03343 Antiencrepamiento
Anti-frizz

Fórmula específica para la protección y el cuidado del cabello frente a las agresiones producidas por los aparatos de secado que generan aire caliente, tales como los secadores, las planchas y las tenacillas. Su acondicionador evita el encrepamiento, dejando el cabello más manejable y brillante evitando así el efecto antiestático.

Specific formula to protect and care for hair from the damage caused by hair dryers that generate heat, hair straighteners and tongs. This conditioner prevents frizz, making the hair shinier and easier to comb, combating the effects of static electricity.

Activador de rizos
Curling activator



u.m.vta: 1  12 

REF.03344

Su fórmula innovadora crea una película que refuerza y revitaliza los rizos, dándoles más definición, más elasticidad e hidratándolos sin apelmazar. Su efecto acondicionador aporta volumen y grosor, dejando el cabello con un aspecto sedoso, brillante y vaporoso.

Its innovative formula creates a film that reinforces and revitalises curls, making them more defined, more elastic and hydrating the hair without weighing it down. Its conditioning effect provides it with volume and thickness, providing the hair with a silky, shiny and fluffy look.

Queratina líquida
Liquid keratin

u.m.vta: 1  12 

REF.03554



La queratina líquida nutre, repara y regenera la cutícula del cabello al instante. Contiene colágeno y proteínas de seda, que nos aportan un efecto acondicionador, consiguiendo un pelo más sano, más fuerte y mejorando en volumen, suavidad y brillo.

Liquid keratin nourishes, repairs and regenerates hair cuticles instantly. It contains collagen and silk proteins that provide a conditioning effect, helping achieve healthier, stronger hair and improving its volume, softness and shine.



Sérúm All for Hair

All for Hair serum

u.m.vta: 120	 120	u.m.vta: 1	 12	
3 ml		250 ml		
REF.03930		REF.03830		



Sérúm protector del cabello, con queratina, filtro UV, aceite de argán y proteínas de seda. Sin aclarado.

10 beneficios en una sola aplicación:

1. Repara el cabello dañado
2. Aporta brillo
3. Protector térmico
4. Suaviza y desenreda
5. Protección UV
6. Evita el encrespamiento
7. Previene puntas abiertas
8. Aporta volumen
9. Facilita el peinado
10. Hidrata en profundidad





Hair protecting serum with keratin, a UV filter effect, argan oil and silk protein. Does not require rinsing.

10 benefits in a single application:

1. Repairs damaged hair
2. Provides shine
3. Protects from heat
4. Softens and untangles
5. UV protection
6. Prevents frizz
7. Prevents open ends
8. Provides volume
9. Assists in brushing
10. Hydrates in depth

Polvos voluminizadores

Hair volum powder



u.m.vta: 1	 15		u.m.vta: 1	 20	
10 g			20 g		
REF. 06316			REF. 06175		



Polvo matificador ultraligero para texturizar. Suave y con efecto mate. Sujeta el peinado y aporta volumen incluso en cabellos finos. Cuanta más cantidad del producto se aplique, obtienes un mayor control y una increíble fijación del cabello. Para un efecto mate más intenso, aplica sobre el cabello húmedo, dándole forma y dejándolo secar. También puedes aplicar el producto sobre el cabello seco para conseguir un control adicional del encrespado y una mayor suavidad. Enriquecido con queratina favoreciendo así la misma en nuestro cabello.

Ultra-light matting powder for texturing. Soft and with matt effect. Hold the hair and add volume even in fine hair. The more amount you apply the more control you get with an incredible fixation. For a more intense matte effect, apply on damp hair, shaping it and letting it dry. You can also apply on dry hair to get additional control of frizz and more softness. Enriched with keratin that favors the resistance of capillary keratin.

Retoca raíces
Hair fibers

u.m.vta: 1  12 

Negro Black	Castaño oscuro Dark brown	Castaño claro Light brown
REF.07277/50	REF.07277/67	REF.07277/65

Rubio oscuro Dark blonde	Rubio claro Light blonde	Rojo Red
REF.07277/66	REF.07277/76	REF.07277/60





Más información
More information





Coloración temporal en Spray.
Color instantáneo. Cubre raíces y canas al instante fundiéndose perfectamente con tu color. Secado rápido y visible en todos los cabellos. Se va con 1 o 2 lavados.

- Cubre raíces y canas
- Coloración temporal
- Secado rápido

MODO DE USO

PREPARACION: Colocar una toalla encima de los hombros.

- Agitar bien y mantener el envase vertical. Vaporizar a unos 15 cm del cabello en seco. No vaporizar en exceso, una pequeña cantidad es suficiente. Dejar secar 1 minuto y peinar. Vaporizar una segunda vez para un color mas intenso.
- Después de rociar las raíces utiliza un peine para distribuir el producto de tus raíces a unos 4 o 5 centímetros sobre el largo, así obtendrás un resultado más natural.

Temporary spray coloring.

Instant color. Instantly covers roots and gray hair, blending perfectly with your color. Quick and visible drying on all hair. It goes with 1 or 2 washes.

- Covers roots and gray hair
- Temporary coloring
- Fast dry



HOW TO USE

PREPARATION: Place a towel over the shoulders.

- Shake well and keep the container upright. Spray about 15 cm from dry hair. Do not over vaporize, a small amount is sufficient. Let dry for 1 minute and comb. Spray a second time for a more intense color.
- After spraying the roots, use a comb to distribute the product from your roots about 4 or 5 centimeters along the length, so you will obtain a more natural result.

Fibras capilares

Hair fibers

u.m.vta: 1  6 

Negro
Black

REF.06436/50



Gris claro
Light grey

REF.06436/72

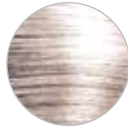

Rubio oscuro
Dark blonde

REF.06436/66



Castaña oscuro
Dark brown

REF.06436/67

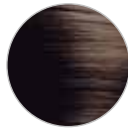

Castaña medio
Medium brown

REF.06436/76



Castaña claro
Light brown

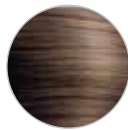

REF.06436/65



- Con dosificador
- Para hombre y mujer. Ideal para la pérdida de densidad capilar. Disimula las zonas de poco pelo de forma rápida y natural
- Se adhiere al cabello dándole mayor volumen y grosor
- Se aplica fácilmente agitando el tarro encima de la zona de aplicación
- Disponible en 6 colores: negro, castaño oscuro, castaño medio, castaño claro, rubio oscuro y gris claro que se adaptan a la tonalidad del color natural del pelo

Laca fibras capilares

Hair fibers spray

u.m.vta: 1  30 

100 ml

REF.06649

Para máxima fijación y sujeción de las fibras

For maximum fixation and fastening of the fibers



Más información
More information



SCAN
ME!



- With dispenser
- For men and women. Ideal for the loss of hair density. It quickly and naturally conceals areas with little hair
- It adheres to the hair giving it more volume and thickness
- It is easily applied by shaking the jar over the application area
- Available in 6 colours: black, dark brown, medium brown, light brown, dark blonde and light grey that adapt to the tone of the natural colour of the hair



Atomizador de fibras capilares Hair fibers atomizer

u.m.vta: 1  12 

REF.07208



- Fácil de usar
- Permite una distribución más uniforme de las fibras capilares en áreas específicas.
- Permite que las fibras se adhieran a tu cabello natural mucho más fácilmente. Se necesita menos cantidad de producto para lograr el look deseado.
- Fácil de almacenar

- Easy to use
- Allows a more even distribution of hair fibers into specific areas.
- It allows the fibers to attach to your natural hair much easier. Less amount of product is needed to achieve desired look.
- Easy to store

CÓMO UTILIZAR:

Vierta las fibras del cabello en la botella de vidrio y coloque el atomizador para pulverizarlas. Presione la bomba hacia arriba y abajo para este propósito.

HOW TO USE:

Pour the hair fibers into the glass bottle and install the atomizer to spray them. Press the pump up and down for this purpose.

Expositor fibras capilares Hair fibers exhibitor

u.m.vta: 1  1

REF.07801

Expositor vacío de regalo

Empty gift display

Incluye 6 tonos fibras capilares + laca fijación



- Ref. 06436/50 Negro 22g. - Ref. 06436/72 Gris claro 22g. - Ref. 06436/66 Rubio oscuro 22g. - Ref. 06436/67 Castaño oscuro 22g. - Ref. 06436/76 Castaño medio 22g. - Ref. 06436/65 Castaño claro 22g.
- Ref. 06649 Laca fijación fibras capilares 100 ml.

Includes 6 shades of hair fibers + fixing lacquer

- Ref. 06436/50 Black 22g - Ref. 06436/72 Light grey 22g
- Ref. 06436/66 Dark blonde 22g - Ref. 06436/67 Dark chestnut 22g - Ref. 06436/76 Medium chestnut 22g - Ref. 06436/65 Light chestnut 22g - Ref. 06649
- Hair fibers spray 100 ml



Lacas Tassel Cosmetics, ideales para recogidos
Tassel Cosmetics hairsprays, ideal for updos

u.m.vta: 1  12 

Normal
Normal

300 ml

REF.06268

750 ml

REF.06265



Fuerte
Strong

300 ml

REF.06269

750 ml

REF.06266



Industrias Oriol 1942, S.L lanza al mercado la nueva línea de acabados "LACAS CAPILARES TASSEL", enriquecidas con aceite de argán, activo rico en ácidos grasos insaturados, vitamina E, así como con beta carotenoides, aportando una capacidad de hidratación elevada y preservando el cabello dándole un brillo y belleza natural.

Su actualizada formulación, muy sustantiva del cabello, permite vaporizados más racionales y forma una película más flexible y elástica capaz de proteger al cabello de los agentes externos como el viento o la humedad, permitiendo mantener cualquier tipo de peinado con el brillo, volumen y sedosidad deseados gracias a su componente aceite de argán.



Su efecto **LONG LASTING** la convierte en ideal para alisar, rizar, dar volumen, recogidos, crear infinidad de peinados y mantener durante todo el día de forma natural y sin apelmazar el peinado. Su composición permite una fácil eliminación con un ligero cepillado. No deja residuos.

Industrias Oriol 1942, SL launches the new line of finishes "CAPILLARY HAIRSPRAYS TASSEL", enriched with argan oil, active rich in established oily acids, vitamin E, as well as with beta carotenoids, providing a high hydration capacity and preserving the hair giving a shine and natural beauty.

Its updated formulation, very substantive of the hair, allows a more rational vaporising and forms a more flexible and elastic film capable of protecting the hair from external agents such as wind or humidity. These products hold any hairstyle with the desired brightness, volume and silkiness thanks to its argan oil component.

Its **LONG-LASTING EFFECT** makes it ideal for straightening and curling or creating volume, updos or an endless number of hairstyles and it maintains the hairstyle naturally throughout the day without weighing it down. The product is easy to eliminate with a light brushing, leaving no residue.

Lacas Tassel Cosmetics, ideales para recogidos
Tassel Cosmetics hairsprays, ideal for updos

u.m.vta: 1  12 

- Extra fuerte
- Extra strong

300 ml

REF.06270

750 ml

REF.06267



ECO
ECO

300 ml

REF.06271



LACA ECO TASSEL proporciona al cabello una excelente fijación aportando un brillo natural a la vez que lo protege de agentes externos como el viento, la humedad, etc. Con las mismas características que las lacas anteriores pero sin gases contaminantes ni perjudiciales para el medio ambiente.

ECO TASSEL hairspray gives the hair an excellent hold, providing a natural shine while protecting it from external agents such as wind, humidity, etc. With the same characteristics as the previous hairsprays but without polluting or harmful gases to the environment.





04

Clips y pinzas Clips & clamps

*Clips, pinzas, horquillas, diademas,
grapas, coleteros...*

*Clips, hairpins, clamps, hair elastics,
hair bands, slides...*

Historia del clip y sus antecedentes History of the clip and its background

El origen de las agujas para sujetar el pelo se remonta al Imperio Asirio y al Antiguo Egipto, 25 siglos a de C. Los restos encontrados muestran que había agujas de madera, marfil, bronce y otros metales, y que algunos estaban decorados con piedras preciosas, convirtiéndose así en objetos de lujo.

En la vieja China el paso de las jóvenes a la vida adulta se escenificaba mediante una ceremonia en la que se les entregaba una aguja para el pelo.

La horquilla clip tal como se conoce actualmente fue inventada por Luis Marcus, un fabricante de cosméticos en San Francisco, después de la Primera Guerra Mundial. El uso del clip se extendió al ponerse de moda el peinado conocido como "bob", corte recto del cabello hasta la altura de la barbilla (de aquí su nombre en inglés "Bobby pin").

The origin of the clips to hold hair dates back to the Assyrian Empire and Ancient Egypt, 25 centuries BC. The remains found show that there were clips made of wood, ivory, bronze and other metals, and that some were decorated with precious stones, thus becoming luxury objects.

In old China, the passage of young women to adulthood was staged through a ceremony in which they were given a hair needle.

The clip hairpin as it is known today was invented by Luis Marcus, a cosmetics manufacturer in San Francisco, after the First World War. The use of the clip spread when the hairstyle known as "bob", a straight cut of hair up to the chin height (hence its name in English "Bobby pin") became fashionable.



Objetivo y forma Objective and form

El clip es un pequeño trozo de acero doblado utilizado para recoger el cabello y mantener el peinado en su lugar.

The clip is a small piece of bent steel used to gather the hair and hold the hairstyle in place.



La boca es la parte abierta del clip, por donde debe entrar el pelo.

The mouth is the open part of the clip, where the hair must enter.

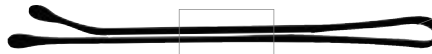

Las dos patas del clip son las que presionan y sujetan el mechón y fijan el clip en su sitio.

The two legs of the clip are what press and hold the lock and hold the clip in place.



El ojo del clip tiene dos funciones: Atrapar la máxima cantidad de pelo posible, y facilitar la presión de las patas.

The eye of the clip has two functions: to catch the maximum amount of hair possible, and to facilitate the pressure of the legs.

Proceso de fabricación Manufacturing process

Los clips que fabricamos y distribuimos están fabricados en alambre de acero, con un alto contenido en carbono. Esta aleación los hace más duros, flexibles y resistentes, permitiendo su uso en múltiples ocasiones sin perder la fuerza de la presión de las patas.

El proceso de fabricación de nuestros clips sigue diversos pasos:

- 1.- Trefilado
- 2.- Laminado
- 3.- Doblado del clip
- 4.- Bola y pintura
- 5.- Encartado o encajado

This alloy makes them harder, flexible and resistant, allowing their use on multiple occasions without losing the force of the pressure of the legs.

The manufacturing process of our clips follows several steps:

- 1.- Wire drawing
- 2.- Laminate
- 3.- Bending the clip
- 4.- Ball and paint
- 5.- Embedded or embedded



Clips DOBLE ONDA
DOUBLE WAVE clips

u.m.vta: 30 360

u.m.vta: 1 16

Cartón 24 clips
Card 24 short clips

Caja 300 clips
Box 300 clips

REF. 04934

REF. 04935

REF. 04934/50

REF. 04935/50



Clips corto de **DOBLE ONDA** para un mejor agarre del cabello y para recogidos de larga duración
Short **DOUBLE WAVE** clips with a better hair grip for long-lasting hairstyles

Clips MATE antideslizante
Non-slip MATTE clips

u.m.vta: 12 120

Cartón 24 clips con bolita
Card 24 clips with ball

REF. 04484/50

REF. 04484/58

REF. 04484/69

REF. 04484/72

u.m.vta: 1 16

Caja 300 clips con bolita
Box 300 clips with ball



REF. 04522/50

REF. 04522/69



Clips Eurostil ondulados

Wave clips

u.m.vta: 12	 120	
-------------	---	---



Cartón 24 clips con bolita
Card 24 clips with ball



REF. 01609



REF. 01609/50

u.m.vta: 1	 16	
------------	--	---

Caja 300 clips con bolita
Box 300 clips with ball



REF. 01610





REF. 01610/50



Clips ondulados

Wave clips

u.m.vta: 12	 96	
-------------	--	---



Cartón 24 clips con bolita
Card 24 clips with ball



REF. 01611



REF. 01611/50

u.m.vta: 1	 16	
------------	--	---

Caja 150 clips con bola
Box 150 clips with ball



REF. 01612



REF. 01612/50

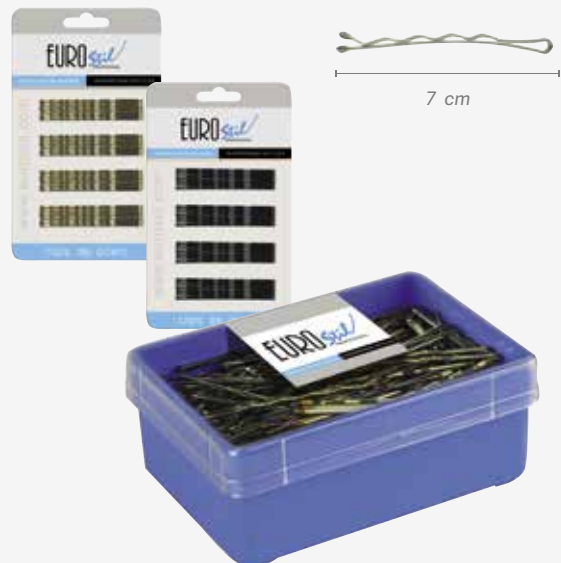

Clips MATE ondulados
Wave MATTE clips

u.m.vta: 1  24

Cartón 12 clips con bolita
Card 12 clips with ball

REF. 07133

u.m.vta: 1  16 



Caja 200 clips con bolita
Box 200 clips with ball

 
REF. 07134 REF. 07134/50



REF. 07133/50

Cajas de clips
Box clips



u.m.vta: 1  16 

700 miniclips sin bolita
700 miniclips without ball

REF. 04088



REF. 04088/50



u.m.vta: 1  16 

300 clips con bolita
300 clips with ball

REF. 01604



REF. 01604/50



u.m.vta: 1  16 

200 clips con bolita
200 clips with ball

REF. 01606



REF. 01606/50

u.m.vta: 1  16 

150 clips con bolita
150 clips with ball

REF. 01608



REF. 01608/50



Cartón clips YO-YO
Card YO-YO clips

u.m.vta: 30 30

12 clips con bolita
12 clips with ball



REF. 01602 REF. 01602/50



Cartón clips ONDINA
Card ONDINA clips

u.m.vta: 60 60

12 clips con bolita
12 clips with ball



REF. 01603 REF. 01603/50



Cartón clips Ondina
Card Ondina clips

u.m.vta: 24 24

24 miniclips
24 miniclips



REF. 02879

12 clips
12 clips



REF. 01601

12 clips
12 clips



REF. 01607



REF. 02879/50



REF. 01601/50



REF. 01607/50

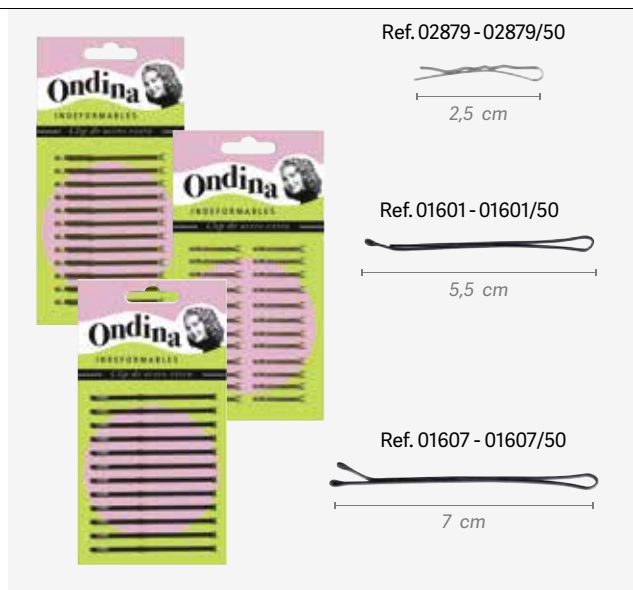

Cartón clips EUROSTIL
Card EUROSTIL clips

u.m.vta: 60 60

12 clips con bolita
12 clips with ball



REF. 01605 REF. 01605/50





Caja de clips

Clips box

u.m.vta: 1  40

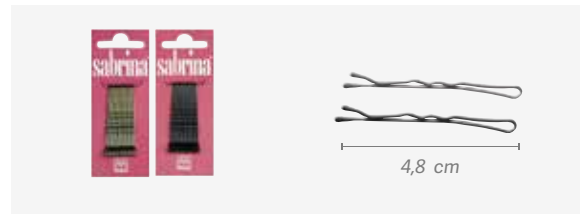
 **REF. 01856**  **REF. 01856/50**
72 docenas clips con bola
72 dz. clips with ball



 **REF. 01863**  **REF. 01863/50**
Con bola, 200 g
With ball, 200 g



 **REF. 01855**  **REF.01855/50**
72 docenas clips con bola
72 dz. clips with ball



 **REF. 01862**  **REF. 01862/50**
Con bola, 200 g
With ball, 200 g 04089





Caja 200 g de horquillas

Hairpins box 200 g

u.m.vta: 1  70

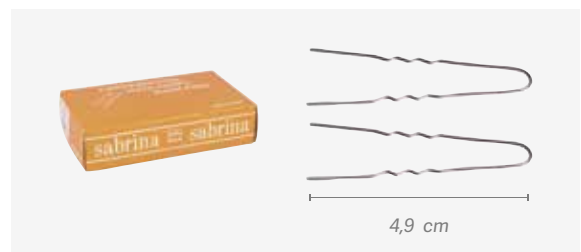
 **REF. 01857**  **REF. 01857/50**
600 horquillas
600 hairpins



 **REF. 01858**  **REF. 01858/50**
150 horquillas
150 hairpins

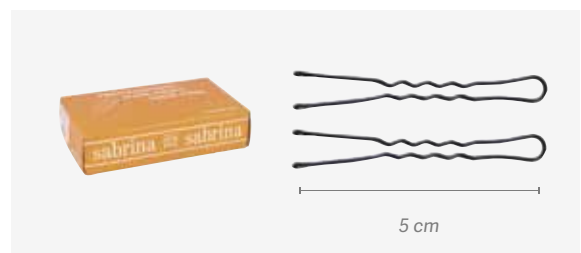

Caja 200 g de horquillas
Hairpins box 200 g

u.m.vta: 1  70





REF. 01861

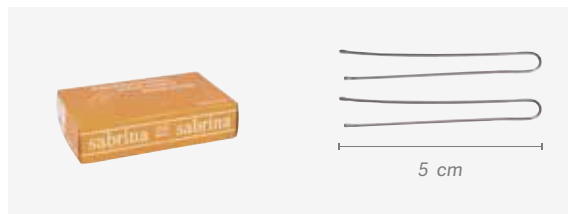

REF. 01861/50

340 horquillas
 340 hairpins



u.m.vta: 1  150



REF. 01860



REF. 01860/50

150 horquillas
 150 hairpins

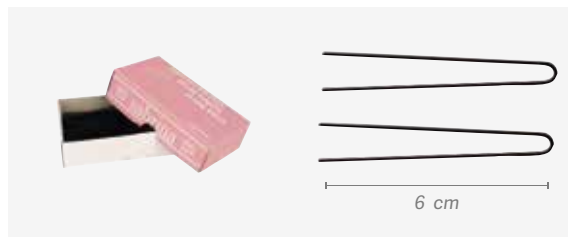

REF. 01859



REF. 01859/50

160 horquillas
 160 hairpins



REF. 04327



REF. 04327/50

95 - 100 horquillas
 95 - 100 hairpins



REF. 04323



REF. 04323/50

95 - 100 horquillas
 95 - 100 hairpins



Horquillas invisibles

Invisinle hairpins



u.m.vta: 30  30

REF. 04089



REF. 04089/50

Bolsa 20 horquillas onduladas
pequeñas invisibles
Bag 20 invisible small wavy
hairpins

u.m.vta: 1  16 

REF. 04087



REF. 04087/50

Caja 500 horquillas onduladas
pequeñas invisibles
Box 500 invisible small wavy
hairpins



u.m.vta: 30  30

REF. 00030



REF. 00030/50

Bolsa 20 horquillas
invisibles
20 invisible hairpins

u.m.vta: 1  16 

REF. 01616



REF. 01616/50

Caja 400 horquillas
invisibles
400 invisible hairpins



u.m.vta: 1  20

REF. 07131



REF. 07131/50

Bolsa 20 horquillas invisibles
Bag 20 invisible hairpins

u.m.vta: 1  16 

REF. 07132



REF. 07132/50

Caja 400 horquillas
invisibles
Box 400 invisible
hairpins



u.m.vta: 10  600



REF. 00701



REF. 00701/50

Bolsa 20 horquillas moño
Bag 20 flat bun hairpins

u.m.vta: 1  16 



REF. 01617



REF. 01617/50

Caja 400 horquillas moño
Box 400 flat bun hairpins



u.m.vta: 12  240





REF. 04532



REF. 04532/50

Bolsa 20 horquillas moño
lisas
Bag 20 flat bun hairpins

u.m.vta: 1  16 



REF.04539



REF. 04539/50

Caja 150 horquillas
moño lisas
Box 150 flat bun
hairpins



u.m.vta: 12  240





REF. 04533



REF. 04533/50

Bolsa 20 horquillas
onduladas invisibles
Bag 20 invisible wavy
hairpins

u.m.vta: 1  16 



REF. 04540



REF. 04540/50

Caja 50 horquillas
onduladas invisibles
Box 150 invisible wavy
hairpins



Bolsas horquillas



Hairpins bags

u.m.vta: 12  240

REF. 04534

REF. 04534/50

Bolsa 10 horquillas moño curvas
Bag 10 bun curve hairpins

u.m.vta: 1  16 

REF. 04541

REF. 04541/50



Caja 150 horquillas moño curvas
Box 150 bun curve hairpins

u.m.vta: 12  240

REF. 04535

REF. 04535/50

Bolsa 10 horquillas invisibles curvas
Bag 10 invisible curve hairpins

u.m.vta: 1  16 

REF. 04542

REF. 04542/50



Caja 150 horquillas invisibles curvas
Box 150 invisible curve hairpins

u.m.vta: 12  240

REF. 04531

REF. 04531/50

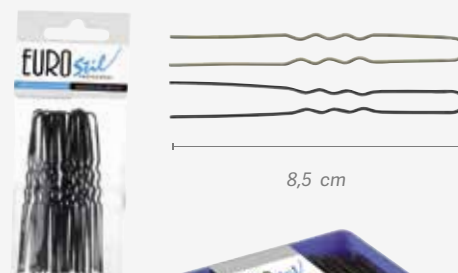
Bolsa 20 horquillas onduladas invisibles
Bag 20 invisible wavy hairpins

u.m.vta: 1  16 

REF. 04538

REF. 04538/50

Caja 150 horquillas onduladas invisibles
Box 150 invisible wavy hairpins



u.m.vta: 12  240



REF. 04530





REF. 04530/50

Bolsa 20 horquillas lisas moño
Bag 20 flat bun hairpins



8,5 cm



u.m.vta: 1  16 



REF. 04537



REF. 04537/50

Caja 150 horquillas lisas moño
Box 150 flat bun hairpins

u.m.vta: 12  240



REF. 04529





REF. 04529/50

Bolsa 6 horquillas moño curvas
Bag 6 bun curve hairpins



9,5 cm



u.m.vta: 1  16 



REF. 04536



REF. 04536/50

Caja 75 horquillas moño curvas
Box 75 bun curve hairpins





Horquillas perla Hairpins pearl

u.m.vta: 12  240

 **REF. 03209**  **REF.03209/50**

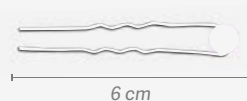
6 horquillas adorno
perla blanca grande
6 ornament hairpins
big white pearl

u.m.vta: 12  240



 **REF. 03212**  **REF. 03212/50**

12 horquillas adorno
perla pequeña blanca
12 ornament hairpins small
white pearl

u.m.vta: 12  120

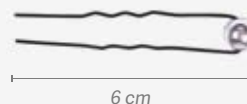

 **REF. 03210**  **REF. 03210/50**

6 horquillas adorno
perla plata grande
6 ornament hairpins
big silver pearl

u.m.vta: 12  120

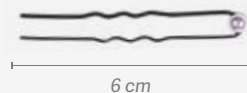

 **REF. 03213**  **REF. 03213/50**

Bolsa 12 horquillas
adorno perla pequeña
plata
Bag 12 ornament hairpins
small silver pearl

u.m.vta: 12  120

 **REF. 03211**  **REF. 03211/50**

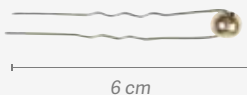
6 horquillas adorno
perla dorada grande
6 ornament hairpins
big golden pearl

u.m.vta: 12  120

 **REF. 03214/50**

12 horquillas adorno perla
pequeña dorada
12 ornament hairpins small
golden pearl

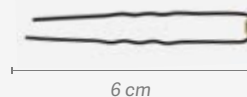

Muñequera imantada Magnetic bracelet

u.m.vta: 1  12

REF. 03631



Para trabajar con más comodidad, teniendo al alcance de tu mano todos los clips y horquillas gracias a nuestro brazalete imantado.

To work more comfortably, keep all your hairclips and hairpins at hand's reach thanks to our magnetic bracelet.



Cajas pinzas metal Metal clips boxes

u.m.vta: 1  16 

120 pinzas pequeñas
Cabeza ancha
120 smal clips
Wide head

Ref. 92

REF. 01657



u.m.vta: 1  16 

120 pinzas pequeñas
Cabeza estrecha
120 small clips
Narrow head

Ref. 91

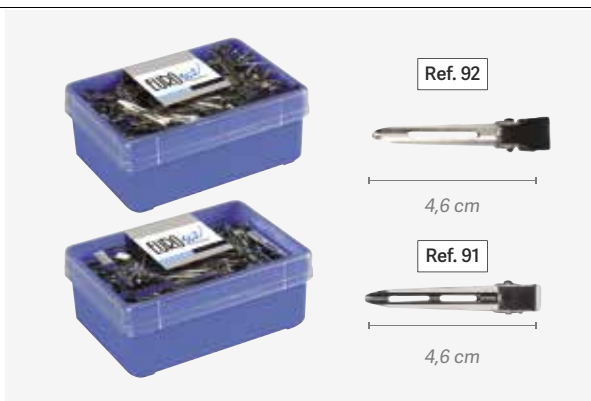
REF. 01656





u.m.vta: 1  12 

120 pinzas doble pata
120 two legs clip

Ref. 94

REF. 01658



u.m.vta: 1  12 

120 pinzas medianas
120 medium clips

Ref. 90

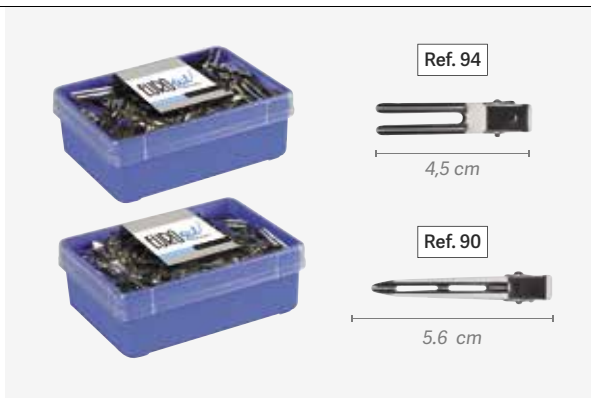
REF. 01655





u.m.vta: 1  12 

120 pinzas grandes
120 large clips

Ref. 95

REF. 01659

u.m.vta: 1  12 

60 pinzas curvadas
60 bend clips

Ref. 93

REF. 01830

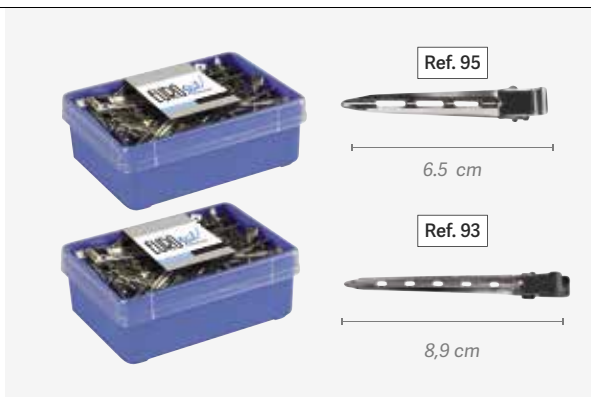

Docena pinzas metálicas
Dozen metal clips

u.m.vta: 12  96

S

REF. 00057



4,5 cm

u.m.vta: 12  96

M

REF. 00058



5 cm

u.m.vta: 12  96

L

REF. 00059



6,2 cm

Docena pinzas inox
Dozen inox clips

u.m.vta: 12  96

S P-20

REF. 01641



5,3 cm



u.m.vta: 12  96

M P-30

REF. 01642



6,7 cm

u.m.vta: 1  100 

L P-50

REF. 01647

Curvada
Bend



8,8 cm

Cartón pinzas
Clips card setting

u.m.vta: 12  96

Docena pinzas curvada aluminio
Dozen aluminium curved clips

REF. 00054



8,8 cm

u.m.vta: 12  36

6 pinzas separación metal. Colores
6 setting metal clips Colours

REF. 00803



11,7 cm

u.m.vta: 12  36

6 pinzas separación metal. Cromadas
6 setting metal clips. Chrome

REF. 00804



11,7 cm

Cartón 10 pinzas metal
Card 10 metal clips

u.m.vta: 12  96

S

REF. 00094



u.m.vta: 12  96

10 pinzas metal pequeñas
Cabeza estrecha
10 small metal clips
Narrow head

S

REF. 00091



u.m.vta: 12  96

10 pinzas metal pequeñas
Cabeza ancha
10 small metal clips
Wide head

S

REF. 00092



Cartón pinzas metal
Card metal clips

u.m.vta: 12  96

M

REF. 00090



u.m.vta: 12  96

L

REF. 00095



u.m.vta: 12  36

6 pinzas curvadas
6 curved clips

REF. 00093



u.m.vta: 1  100 

6 pinzas plástico
curvadas. Colores
6 curved plastic clips
Colours

REF. 00055



u.m.vta: 12  48

6 pinzas plástico
corazón
6 plastic heart clip

REF. 00086



u.m.vta: 1  50 

6 pinzas plástico
profesional
6 professional plastic
clips

REF. 00075





Caja de 60 pinzas de plástico pequeñas Box 60 small plastic clips

u.m.vta: 1  20 

REF. 00046





Caja de 60 pinzas de plástico medianas Box 60 medium plastic clips

u.m.vta: 1  20 

REF. 00056





Caja de 60 pinzas de plástico grandes Box 60 large plastic clips

u.m.vta: 1  18 

REF. 00066





Conjunto juego para moldeado Perm set

u.m.vta: 1  6 

REF. 00687



Clip auxiliar Assistant clip

u.m.vta: 1  12 

Blíster 2 pinzas especial separaciones
Blister 2 special separations clips

REF. 04369





Sostiene el cabello fácilmente sin enredarlo y sin estropear el peinado. De diseño sencillo y a la vez elegante. Una parte del clip sujeta un mechón y la otra provista de cerdas sostiene otro mechón. Es como tener una asistente de salón en casa.

Holds hair easily without tangling it or messing up hairstyles. It has an understated yet elegant design. One part of the clip holds one strand of hair and the other one, which is fitted with bristles, holds another strand. It's like having a salon assistant in your own home.

Para teñir o realizar unas mechas siga las siguientes instrucciones:
1. Haga una separación central en el cabello y a continuación aplique el color
2. Separe el primer mechón de cabello, sujételo mediante el clip auxiliar y a continuación aplique el color sobre este mechón
3. Separe el mechón siguiente, colóquelo sobre el clip y sujételo de forma segura mediante las púas
4. Repita la operación hasta completar la aplicación del tratamiento

To dye or create highlights, please follow the instructions below:
1. Comb the hair to either side and apply the colour
2. Separate the first strand of hair, hold it with the auxiliary clip, and apply the colour to the strand of hair
3. Separate the next strand, place it on the clip and hold it securely between the bristles
4. Repeat this process until the treatment has been applied completely



Caja pinzas antideslizantes Box non-slip clips

u.m.vta: 1  12 

REF. 04368

- 4 pinzas antideslizantes
- Con goma
- 4 non-slip clips
- With rubber



u.m.vta: 1  20 



REF. 04376

- 6 pinzas antideslizantes
- Con goma
- 6 non-slip clips
- With rubber



Caja 6 pinzas antioxidantes**Box 6 antioxidant clips**u.m.vta: 1  20 Con dientes
With teeth

REF. 03259



**Bolsa de 6 pinzas metal-plástico****Bag 6 assorted metal plastic clips**u.m.vta: 1  20 Surtido de colores
Assorted colours

S



L

REF. 02525/99

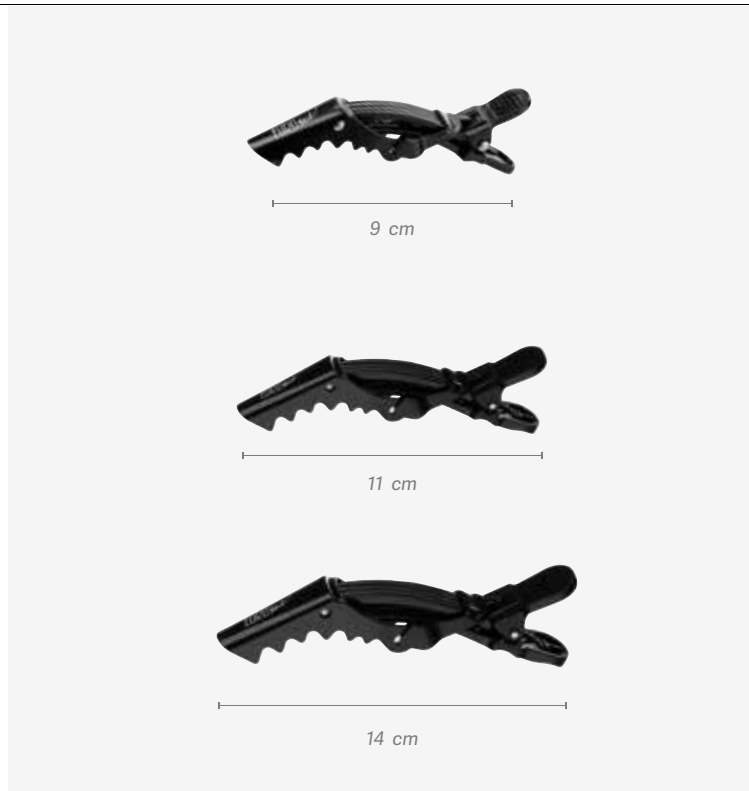

REF. 02524/99

**Bolsas de 4 pinzas DRAGÓN****Bag 4 DRAGON clips**u.m.vta: 1  90 

REF. 04374



u.m.vta: 1  24 

REF. 03059

u.m.vta: 1  40 

REF. 04375

Bolsa de 6 pinzas plástico negras
Bag 6 black plastic clips



u.m.vta: 20  20 

Con goma
 With rubber

REF. 02526



Caja de 6 pinzas antideslizantes
Box 6 non-slip clips



u.m.vta: 1  20 

Con goma
 With rubber

REF. 04741



Cartón 4 pinzas con goma negra
Card 4 clips with black rubber

u.m.vta: 1  12 

REF. 06388

REF. 06389

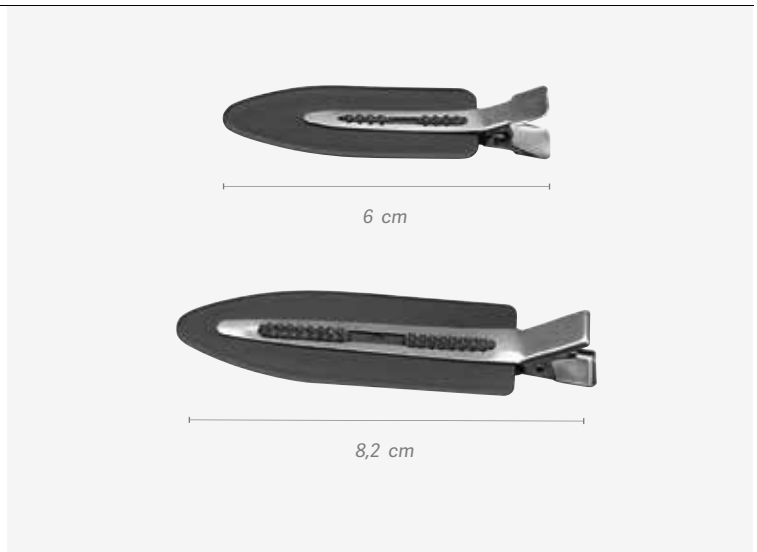

Pinzas negras con goma para no dejar marca en el pelo. Muy útiles para apartar el cabello en sesiones de maquillaje ya que no dejan marca.

Black clips with rubber to prevent marks on the hair. Very useful to separate the hair in makeup sessions as they leave no marks.

Cartón ranitas

Card clips

u.m.vta: 1	 10	
------------	--	---

12 ranitas negras
12 black clips

REF. 07455/50



u.m.vta: 1	 10	
------------	--	---

12 ranitas colores de verano
12 summer colours clips

REF. 07455

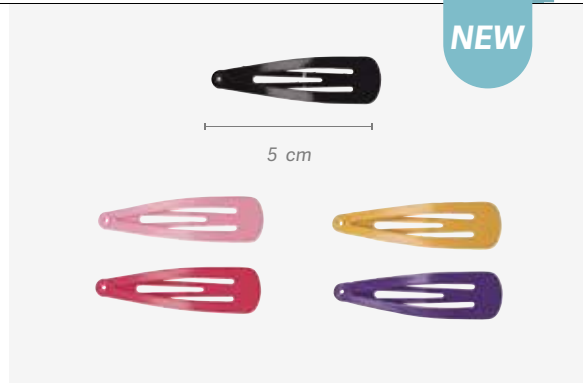

NEW

Cartón ranitas

Card clips

u.m.vta: 1	 60
------------	--

24 ranitas negras
24 black clips

REF. 03482



u.m.vta: 1	 60
------------	--

24 ranitas colores flúor
24 fluorescent colours clips

REF. 03481



NEW

u.m.vta: 1	 60
------------	--

12 ranitas negras
12 black clips

REF. 03480



u.m.vta: 1	 60
------------	--

12 ranitas colores flúor
12 fluorescent colours clips

REF. 03479



NEW

Bolsa de 6 grapas de aluminio
Bag 6 aluminium clamps

u.m.vta: 12  36

S



REF. 00080

L

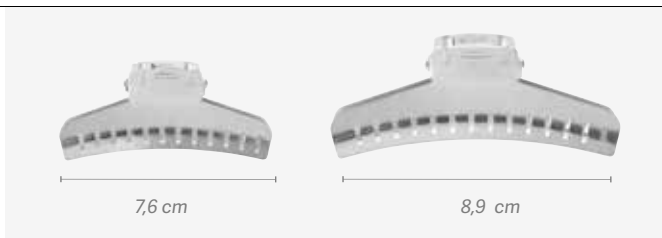
REF. 00070



Bolsa 12 grapas plástico, grande
Bag 12 plastic clamps, large

u.m.vta: 12  120 

L

  
 REF. 00084

L

 REF. 00084/50

   
 REF. 00084/76



Bolsa de 6 grapas con separador grande y de plástico
Bag 6 plastic clamps, large

u.m.vta: 12  48

REF. 00081

REF. 00081/50

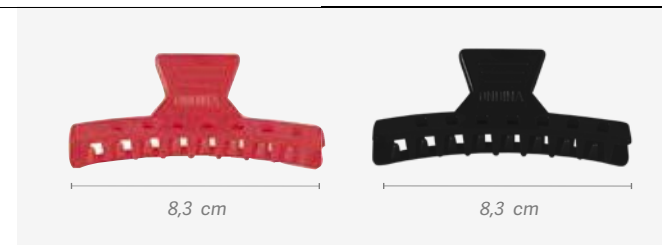

Bolsa de 6 grapas de plástico grande, surtido en colores
Bag 6 large plastic clamps, assorted colours

Translúcido
 Translucent

u.m.vta: 30  30

REF. 00078





REF. 00078/51

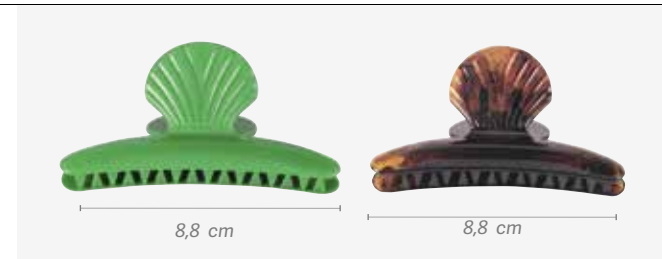

REF. 00078/53



Bolsa de 12 grapas separadoras
Bag 12 separators clamps

u.m.vta: 1  20 

REF. 04738



Grapa de corazones, mini
Mini heart clamp

u.m.vta: 12  600



XS

REF. 00072



XS

REF. 00072/52



u.m.vta: 12  120



REF. 00100/50



REF. 00100



REF. 00100/52

Colores marmoleados
 Marbled colors



u.m.vta: 6  120



REF. 00071/50



REF. 00071/51

Translúcido
 Translucent



Grapa de corazones
Super large

u.m.vta: 6  72



XL

REF. 00073/50





XL

REF. 00073/51

Translúcido
 Translucent



Bolsa de 12 grapas de plástico negras
Bag 12 separators black plastic clamps

u.m.vta: 1  12 

REF. 07807/50



Bolsa de 12 pinzas
Bag 12 clamps bag

* colores translúcidos

u.m.vta: 1  20

 S

REF. 04422

 S

REF. 04421

Translúcido
 Translucent

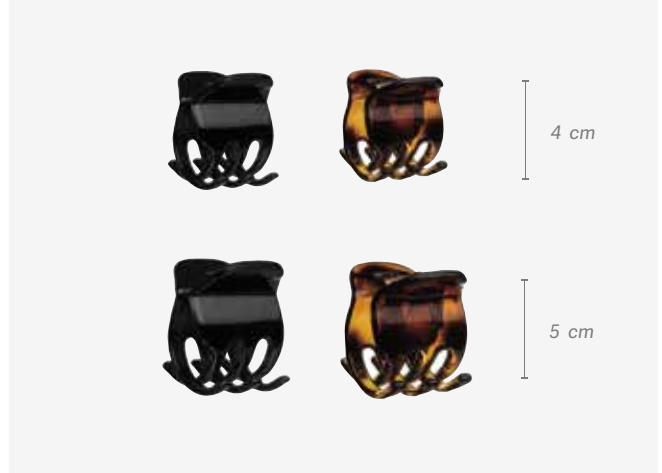

 L

REF. 04424

 L

REF. 04423

Translúcido
 Translucent

Grapa de corazón super-mini
Super-mini heart clamp

u.m.vta: 12  600



REF. 00143/50



REF. 00143/51

Translúcido
 Translucent

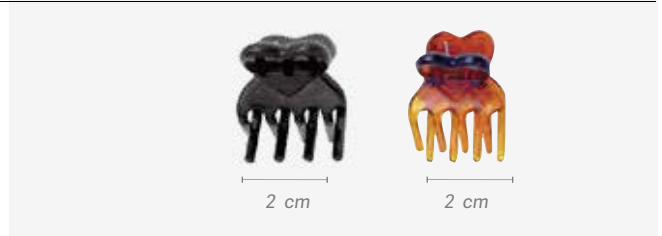

Diadema poliamida, colores surtidos
Head band polyamide, assorted colours

u.m.vta: 12  12

S

REF. 01914

M

REF. 01086

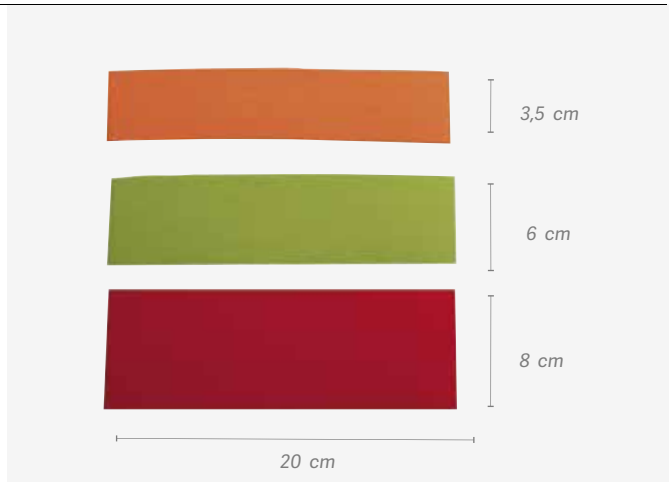

L

REF. 01087



Cartón 8 gomas gruesas

Card 8 thick elastic hair

u.m.vta: 1  10 

Colores tierra
Earth tones

REF. 07450

Negro
Black

REF. 07450/50



Marrón
Brown

REF. 07450/69



Cartón 15 gomas finas

Card 15 thin elastic hair

u.m.vta: 1  10 

Colores tierra
Earth tones

REF. 07451

Negro
Black

REF. 07451/50



Marrón
Brown

REF. 07451/69



Cartón 9 coleteros mini

Card 9 mini elastic hair

u.m.vta: 1  10 

Negro
Black

REF. 07452/50

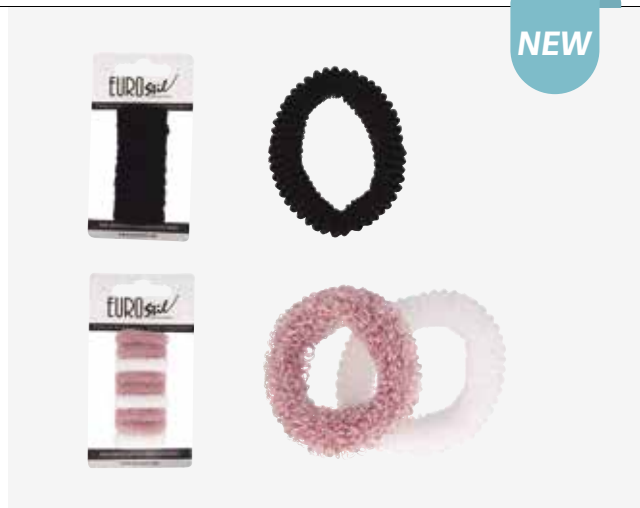

Rosas y blancos
Pinks and whites

REF. 07452



Cartón 20 coleteros mini

Card 20 mini elastic hair

u.m.vta: 1  10 

Negro
Black

Rosas y blancos
Pinks and whites

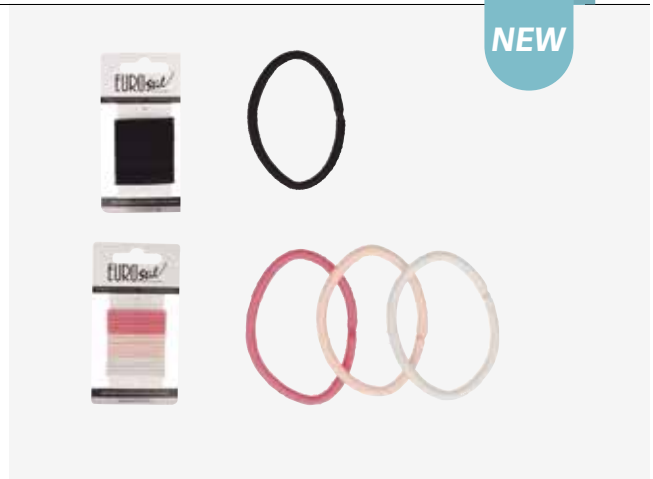

REF. 07453/50

REF. 07453



Cartón 5 coleteros ropa

Card 5 clothes elastic hair

u.m.vta: 1  10 

Negro
Black

Arcoiris
Rainbow

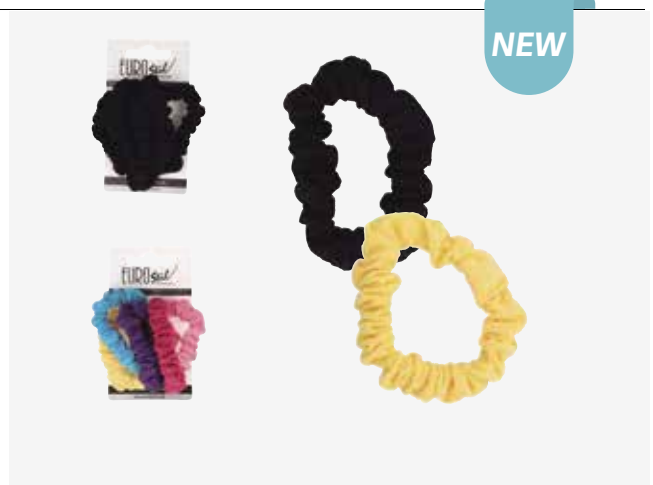

REF. 07454/50

REF. 07454



Cartón 8 gomras trenzadas

Card 8 braided elastic hair

u.m.vta: 1  10 

Negro
Black



Colores nude
Nude colors

REF. 07460/50

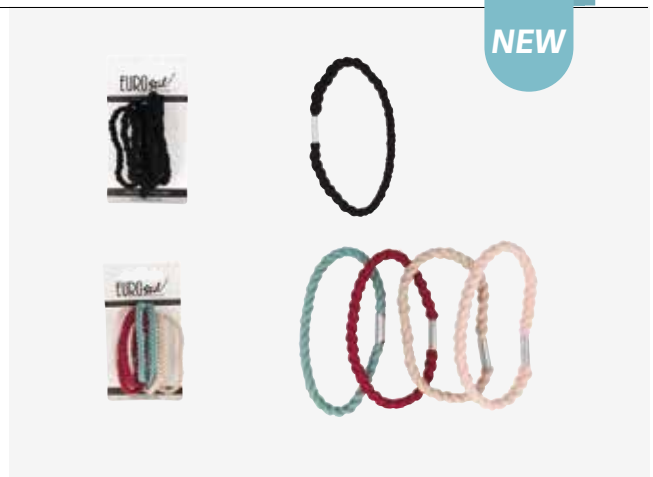
REF. 07460



Cartón 25 gomasp Card 25 elastic hair

u.m.vta: 1  10 

Colores fríos
Cold tones

Negro
Black

Marrón
Brown



REF. 07457

REF. 07457/50

REF. 07457/69



Cartón 10 gomasp Card 10 elastic hair

u.m.vta: 1  10 

Colores dorados
Gold tones

Negro
Black

Marrón
Brown



REF. 07462

REF. 07462/50

REF. 07462/69



Pack 2 gomasp espiral forradas 2-pack spiral lined rubber bands

u.m.vta: 1  10 

Azul y rojo
Blue and red

Negro
Black

Marrón
Brown

REF. 07459



REF. 07459/50

REF. 07459/69



Cartón 12 gomas con gancho

Card 12 elastic hair with hook

u.m.vta: 1  40 



REF. 00640



REF. 00637



REF. 00858

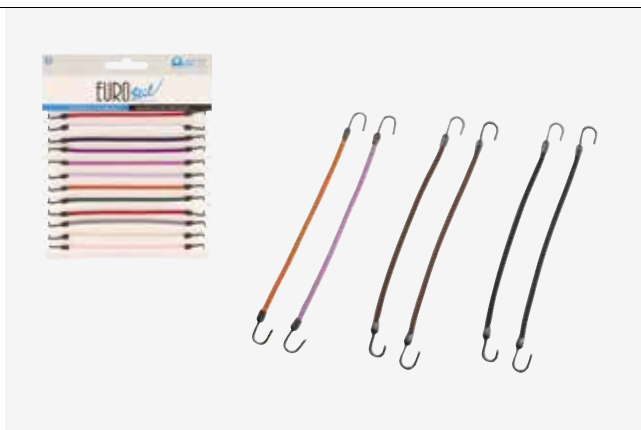

Cartón 24 gomas, colita

Card 24 elastic hair, small

u.m.vta: 1  60



REF. 00634





REF. 00635



Cartón 24 coleteros pequeños

Card 24 small elastic hair

u.m.vta: 1  100 

Poliamida
Polyamide



REF. 00811/50





REF. 00811/69



Cartón 24 coleteros grandes

Card 24 large elastic hair

u.m.vta: 1  60 

Poliamida
Polyamide



REF. 00812



REF. 00812/50



REF. 00812/69

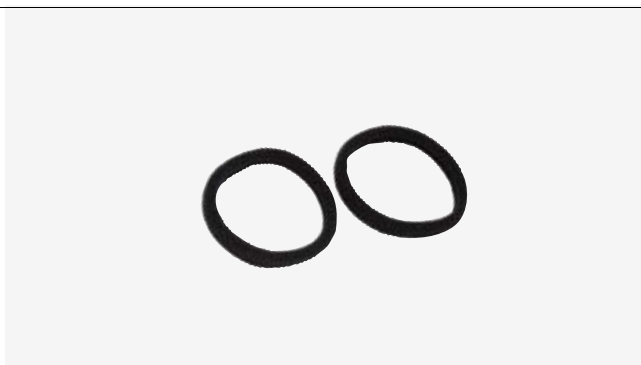

Bolsa 10 coleteros mini
Bag 10 mini elastic hair

u.m.vta: 12  96

     
 REF. 03384/50 REF. 03384



Bolsa 10 coleteros anilla
Bag 10 small elastic hair

u.m.vta: 12  96

REF. 03383/50 REF. 03383



Pack 2 gomaspiral
Pack 2 spiral elastic hair

u.m.vta: 12  12

  
 REF. 04840/50 REF. 04840/69 REF. 04840/56



u.m.vta: 12  12

  
 REF. 04807/50 REF. 04807/69 REF. 04807/56



u.m.vta: 12  12

  
 REF. 04806/50 REF. 04806/69 REF. 04806/56



Cartón 24 coleteros trenzados colores
Card 24 braided coloured elastic hair

u.m.vta: 1  16

REF. 02261



Cartón 24 coleteros trenzados negros
Card 24 black braided elastic hair

u.m.vta: 1  16

REF. 02261/50

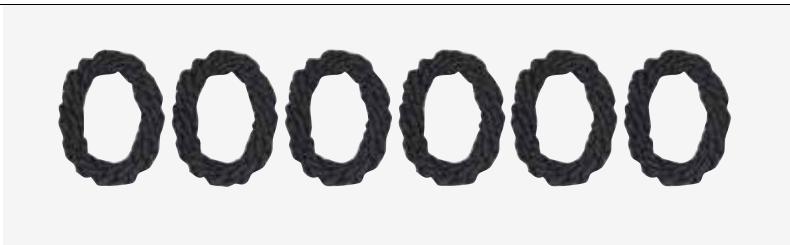

Cartón 48 gomass forradas cerradas negras
Card 48 black elastic hair

u.m.vta: 1  24

REF. 03486

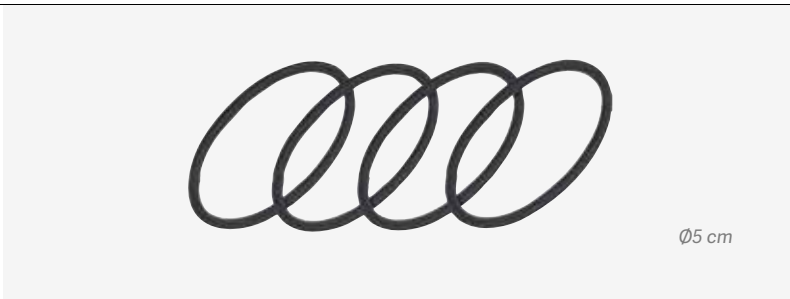



Bolsa 5 coleteros silicona
Bag 5 silicone elastic hair

u.m.vta: 1  100

 REF. 03467/50

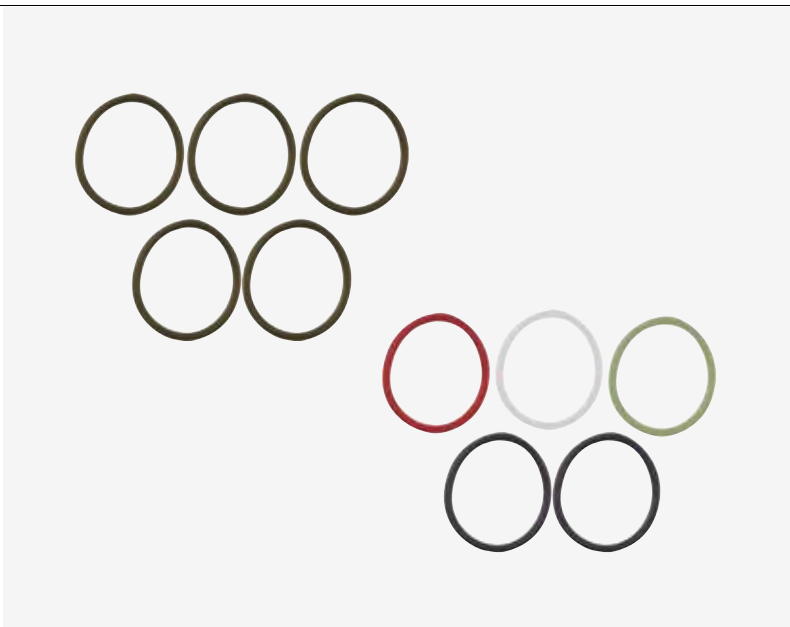
 REF.03467/69  REF. 03467/99



Bolsa 50 gomitas de TPU para peinados**Bag 50 TPU hair elastics for hairstyles**u.m.vta: 12  120 

REF. 06808

REF. 06809

- No abrasivas
- Muy resistentes
- No tóxicas
- Ideales para trenzas y recogidos

REF. 06810

REF. 06811

- Non abrasive
- Very resistant
- Non-toxic
- Ideal for braids and updos

**Bolsa 2000 gomitas elásticas****Bag 2000 elastic bands assorted**u.m.vta: 12  84100 g aprox
Bag 100 g aprox

REF. 03397

**Coletero anti piojos****Anti-lice elastic hair**u.m.vta: 1  12

REF. 04717

REF. 04719

REF. 04718

REF. 04928



- Formulado con peregrina, componente que resulta efectivo y duradero para repelar piojos y otros insectos
- Eficacia demostrada contra los piojos en un 99%
- Antialérgico y sin olor
- Tejido suave
- Aseguramos 100 lavados sin perder su eficacia

- Formulated with pilgrim, a component that is effective and durable to repel lice and other insects
- Efficacy demonstrated against lice by 99%
- Antiallergic and odorless
- Soft fabric
- We ensure 100 washes without losing their effectiveness

Turbante decorado

Decorated turban

u.m.vta: 1  10

La elegancia, el glamour y la comodidad se unen en nuestra línea de turbantes bordados sin costuras, diseñados y fabricados totalmente en España. Colores variados para lucirlos en cualquier ocasión. Un complemento ideal para la mujer más actual. 6 modelos disponibles. 100% poliéster.

Elegance, glamour and comfort come together in our line of seamless embroidered turbans. Designed and manufactured entirely in Spain. They come in a range of colours, suitable for any occasion. An ideal complement for the modern woman. 100% polyester.

Negro
Black



REF. 06055/50

Azul
Blue



REF. 06055/59

Verde
Green



REF. 06055/62

Beige
Beige



REF. 06055/65

Rosa
Pink



REF. 06055/70

Gris
Grey



REF. 06055/72

Granate
Garnet



REF. 06055/73

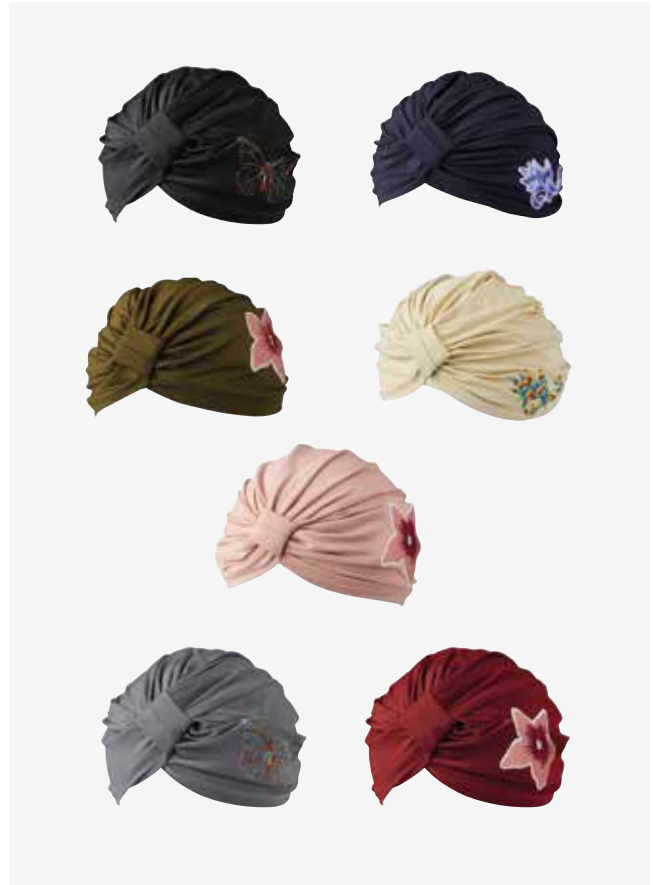

Bolsa 6 turbantes decorados de colores variados

Bag 6 decorated mix colored turbans

u.m.vta: 1  100

REF. 06055/99





EUROSIL



Turbantes decorados

www.eurostil.com

Clips con perlas 2 ud.
Hair grips with pearls 2 pcs



u.m.vta: 1  12 

REF. 06937

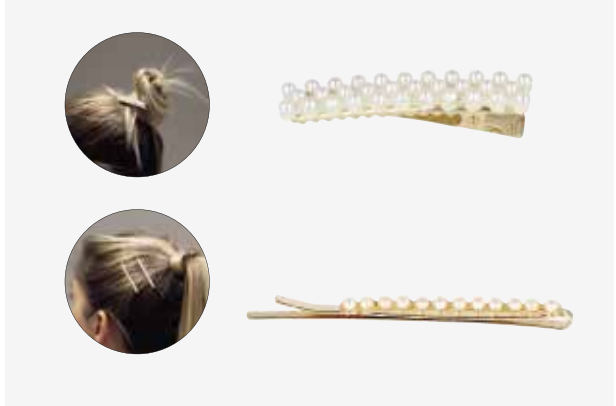

REF. 06930





u.m.vta: 1  12 

REF. 06932



REF. 06933





u.m.vta: 1  12 

REF. 06934

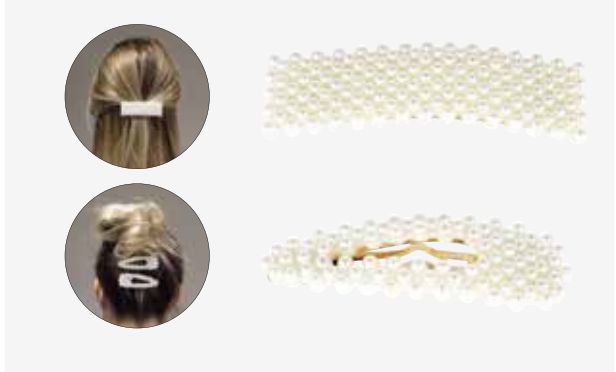

REF. 06935



u.m.vta: 1  12 



REF. 06936

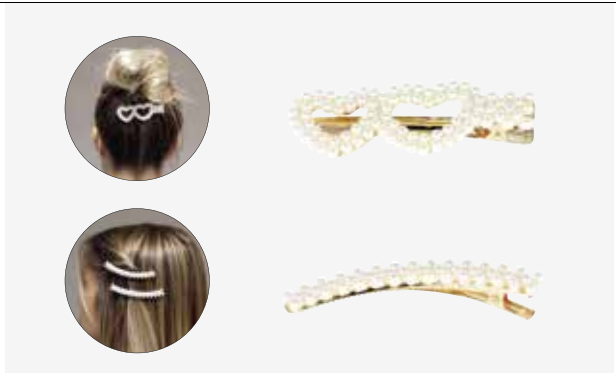

REF. 06938



Clips dorados con strass 2 ud.
Gold hair clips with strass 2 pcs

u.m.vta: 1  12 

REF. 06928



REF. 06929

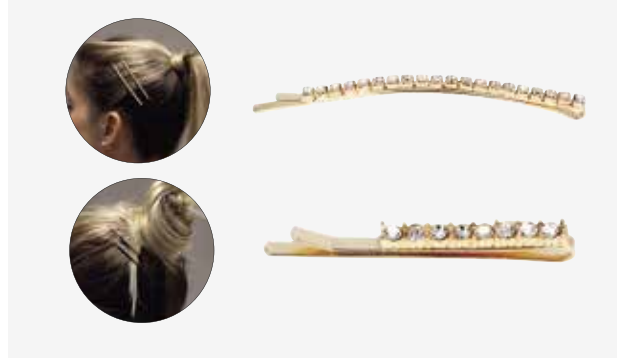



Pinzas rectángulo perlas 2 ud.
Hair grips with pearls 2 pcs

u.m.vta: 1  12 

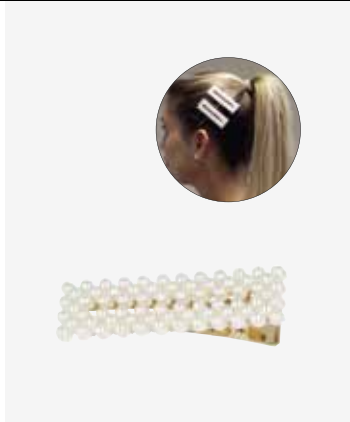
REF. 06939





Clips bolas cristal blanco facetado 2 ud.
Clips with white faceted glass balls 2 pcs

u.m.vta: 1  12 

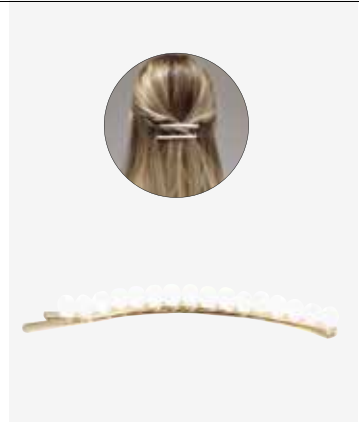
REF. 06931





Diadema con perlas grandes 2 ud.
Hairband with big pearls 2 pcs

u.m.vta: 1  12 

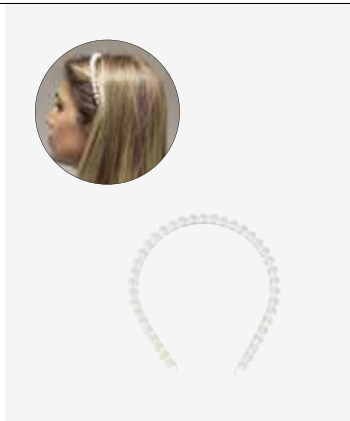
REF. 06940





Pasador redondo con perlas 2 ud.
Round hair slide with 2 pearls 2 pcs

u.m.vta: 1  12 

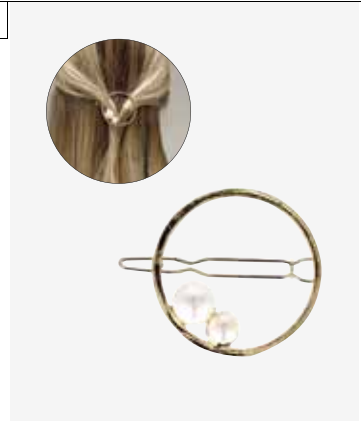
REF. 06941



Pasador con letras de love
Hair slide with love letters

u.m.vta: 1  10 

REF. 07463



NEW

SPUNLACE

EURO *Stil*
PROFESIONAL

TOALLAS
TOWELS
SERVIETTES
TOALHAS
ASCIUGAMANI

Product

05

Papel Paper

Toallas, ringlets...

Towels, ringlets...



Bolsa de 75 Toallas CELULOSA
Bag with 75 CELLULOSE towels



u.m.vta: 1  16 

- Especial manicura
- Special manicure

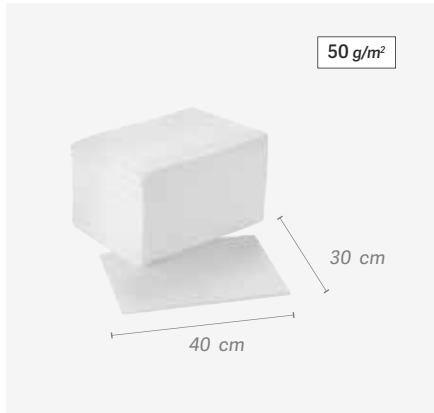
REF. 04204





Bolsa de 90 toallas CELULOSA
Bag with 90 CELLULOSE towels

u.m.vta: 4  4 

REF.04076



Bolsa de 25 toallas SPUNLACE
Bag 25 SPUNLACE towels

u.m.vta: 1  24 

50 g/m²

40 x 90 cm

REF. 04916

u.m.vta: 1  28 

50 g/m²

40 x 80 cm



REF. 03221

- Dobladas a 20 x 20 cm
- 50% poliéster / 50% viscosa

- Bent to 20 x 20 cm
- 50% polyester / 50% viscose



Bolsa de 100 toallas SPUNLACE
Bag with SPUNLACE 100 towels



u.m.vta: 1  20 

REF. 03283

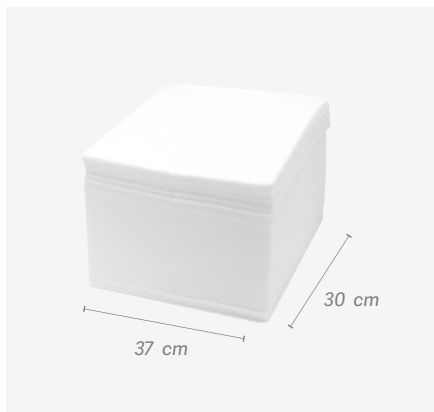
- Súper absorbentes
- Super absorbent towels



Bolsa 35 toallas SPUNLACE
Bag 35 SPUNLACE towels

u.m.vta: 1  12 

REF. 04509

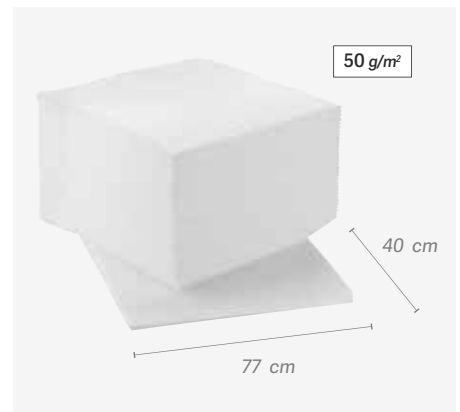

- Súper absorbentes
- Toallas dobladas

- Super absorbent
- Bent towels



Bolsa 100 toallas SPUNLACE

Bag 100 SPUNLACE towels

u.m.vta: 1  6 

50 g/m²

REF. 07301

- Composición 50% viscosa / 50% Poliéster
- De gran resistencia y absorción, versátil, práctico y desechable.
- Totalmente libre de látex, de tacto extra suave
- Súper absorbentes

- Composition 50% viscose / 50% polyester
- Highly resistant and absorbent, versatile, practical and disposable.
- Totally latex-free, extra soft-touch
- Super absorbent



Papel permanente

Pop-up paper

u.m.vta: 48  48

REF.00667

- Caja 1000 hojas
- Box 1000 sheets



Papel permanente

Pop-up paper

u.m.vta: 72  72

REF.01136

- Caja dispensadora 500 hojas
- Dispenser box 500



Papel permanente súper grande

Extra large pop-up paper

u.m.vta: 72  72

REF.01230



- Caja dispensadora 1000 hojas
- Súper fuerte. Absorbente y poroso
- Dispenser box 1000 papers
- Super strong. Absorbent and porous



Papel permanente perforado

Perforated pop-up paper

u.m.vta: 48		48
-------------	---	----



REF.04430

- Caja 1000 hojas papel
- Box 1000 sheets



Dispensador POLLIÉ

POLLIÉ dispenser

u.m.vta: 1		20	
------------	---	----	---



REF. 00802

- Dispensador 20 libritos x 200 hojas papel POLLIÉ
- Dispenser 20 pop-up paper x 200 POLLIÉ sheets



Dispensador RINGLETS

RINGLETS dispenser

u.m.vta: 1		20	
------------	---	----	---



REF. 00656

- Dispensador 20 libritos x 200 hojas papel ringlets
- Dispenser 20 pop-up paper x 200 ringlets sheets



Mañequera para papel ringlets

Holder pop-up paper ringlets

u.m.vta: 1		100	
------------	---	-----	---



REF.00657/50



REF.00657







06

Formación Training

*Cabezas maniquí, trípodes,
soportes para mesa...*

*Mannequin heads, tripods, man-
nequin head holders...*

Cabeza maniquí, CABELLO 100% NATURAL
Mannequin head, 100% NATURAL HAIR

u.m.vta: 1  10 



Con soporte incluido
 With holder included

- 42 implantes por cm²
- 6-7 cabellos por implante
- 260 cabellos aprox por cm²
- Para corte, decoloración, coloración, permanente, peinados, recogidos, secado y planchado
- Temperatura máxima 180°C
- Implantación clásica 90°

- 42 insertions per cm²
- 6-7 hairs per implant
- 260 hairs per cm²
- For cutting, bleaching, coloring, permanent, combing, updo, drying and ironing
- 180°C maximum temperature
- 90° classic insertion

Castaño · Brown

REF. 01455

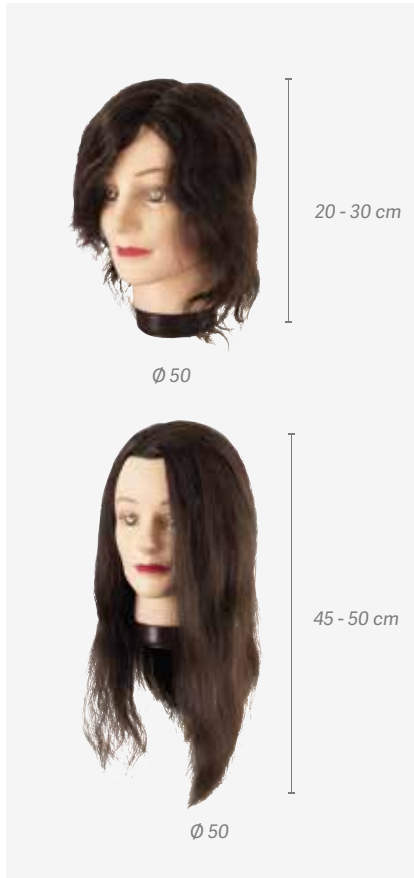

REF. 00624



REF. 00603



REF. 01142



Rubio muy claro · Very light blond

REF. 04251

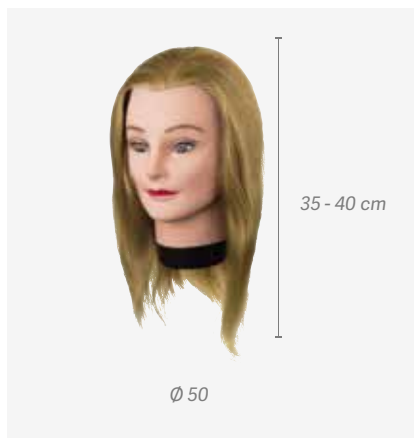

- No decolorar
- Do not bleach

Rubio claro · Light blond



REF.04586



- Sin pestañas
- No decolorar
- Without eyelashes
- Do not bleach

Cabeza maniquí, CABELLO 100% NATURAL

Mannequin head, 100% NATURAL HAIR

u.m.vta: 1  10 

- 42 implantes por cm²
- 7-8 cabellos por implante
- 320 cabellos aprox por cm²
- Para corte, decoloración, coloración, peinado, secado y planchado
- Temperatura máxima 180°C

- 42 insertions per cm²
- 7-8 hairs per implant
- 320 hairs per cm²
- For cutting, bleaching, coloring, combing, drying and ironing
- 180°C maximum temperature



Castaño claro · Light brown

Leia

REF. 06642

- Implantación clásica
- Classic insertion

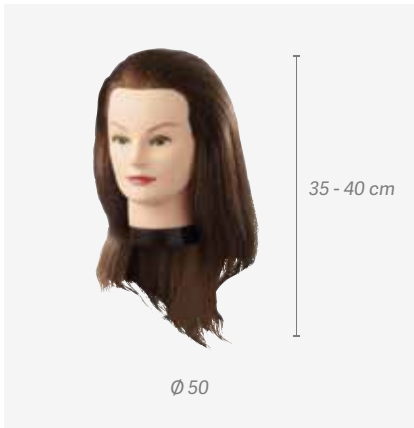

Amber

REF. 06643

- Implantación natural
- Natural insertion



Jenny

REF. 06644

- Implantación natural
- Natural insertion

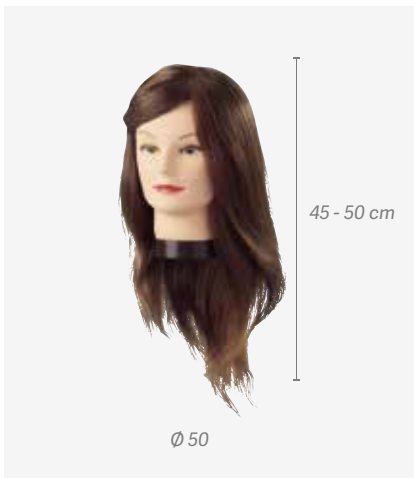

Daisy

REF. 06645

- Implantación natural
- Natural insertion



Lucy

REF. 06149

- Implantación natural 45°
- 45° natural insertion

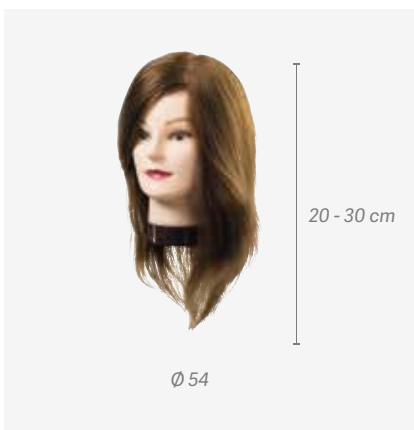



Lucy

REF. 04910

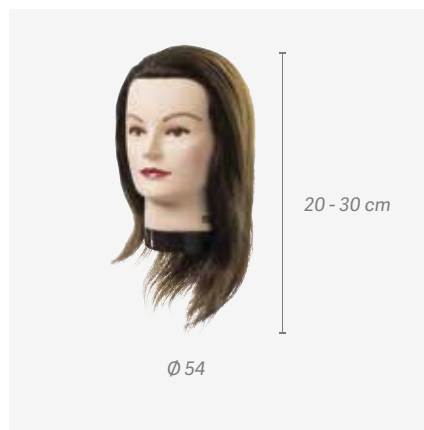
- Implantación clásica 90°
- 90° classic insertion



Cabeza maniquí, CABELLO 100% NATURAL Mannequin head, 100% NATURAL HAIR

u.m.vta: 1  10 

- Con pestañas
- Implantación natural 45°
- 42 implantes por cm²
- 6-7 cabellos por implante
- 260 cabellos aprox por cm²
- Para corte, decoloración, coloración, permanente, peinados, recogidos, secado y planchado
- Temperatura máxima 180°C

- With eyelashes
- 45° natural insertion
- 42 implants per cm²
- 6-7 hairs per implant
- 260 hairs per cm²
- For cutting, bleaching, coloring, permanent, combing, updo, drying and ironing
- 180°C maximum temperature

Negro · Black

Chloe

REF. 04904



- Cabello remy
- Remy hair



Maniqués hombre, CABELLO 100% NATURAL
Men mannequin, 100% NATURAL HAIR

Con soporte incluido
 With holder included



u.m.vta: 1  10 

- 42 implantes por cm²
- 7-8 cabellos por implante
- 320 cabellos aprox por cm²
- Para corte, decoloración, coloración, peinado, secado y planchado
- Temperatura máxima 180°C

- 42 insertions per cm²
- 7-8 hairs per implant
- 320 hairs per cm²
- For cutting, bleaching, coloring, combing, drying and ironing
- 180°C maximum temperature

Castaño · Brown

REF. 02495

Hombre · Man



15 - 18 cm

Ø 58

- Implantación natural 45°

- 45° natural insertion

Castaño con barba · Brown with beard

REF. 02169





15 - 18 cm

Ø 58

- Implantación natural 45°
- También para corte barba

- 45° natural insertion
- Also for beard cutting

Castaño claro JOE · Light brown

u.m.vta: 1  10 

REF. 04909



- Implantación clásica 90°
- 90° classic insertion

REF. 06147

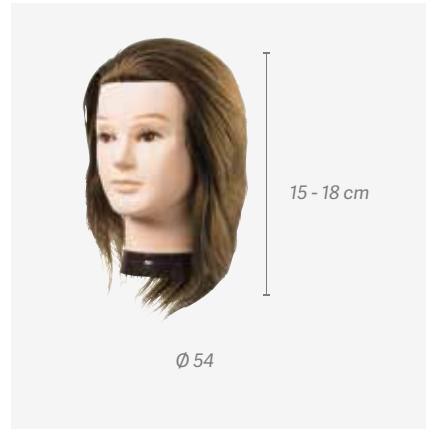
- Implantación natural 45°
- 45° natural insertion



Castaño claro con barba DANIEL · Light brown with beard

u.m.vta: 1  10 

REF. 04908

- Implantación clásica 90°
- 90° classic insertion



REF. 06148

- Implantación natural 45°
- 45° natural insertion



Cabeza maniquí, CABELLO 100% SINTÉTICO

Mannequin head, 100% SYNTHETIC HAIR

u.m.vta: 1  10 

- Implantación natural 45°
- 42 implantes por cm²
- 5-6 cabellos por implante
- 210 cabellos aprox por cm²
- Para corte, peinado, recogido, secado y planchado
- Temperatura máxima 180°C
- No decolorar, teñir, ni permanente

- 45° natural insertion
- 42 implants per cm²
- 5-6 hairs per implant
- 210 hairs per cm²
- For cutting, combing, updo, drying and ironing
- 180°C maximum temperature
- Do not bleach, dye, or permanent



Rubio · Blond



REF. 04954

REF. 04955

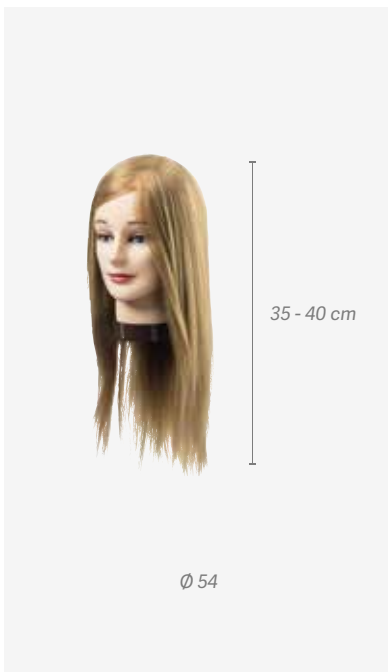
REF. 04956



Cabeza maniquí, CABELLO SINTÉTICO 100% PRO-H
Mannequin head , 100% SYNTHETIC hair PRO-H

u.m.vta: 1  10 

Con soporte incluido
 With holder included



- Para corte, coloración, recogido, secado y planchado
- Temperatura máxima 140°C
- No decolorar
- 42 implantes por cm²
- 6-7 cabellos por implante
- 260 cabellos aprox. por cm²
- Implantación clásica 90°C
- Apta para tinte y permanente

- For cutting, combing, updo, drying and ironing
- 140° maximum temperature
- Do not bleach
- 42 implants per cm²
- 6-7 hairs per implant
- 260 hairs per cm²
- 90°C classic insertion
- Suitable for dyeing and permanent

Rubio claro · Light blond

REF. 02543

REF. 02544

REF. 02545



TINTE Y PERMANENTE
 DYE AND PERM



MAX 140°



BERGMANN

HAIR AND MORE...

Cabeza maniquí, CABELLO 100% NATURAL
Mannequin head, 100% NATURAL HAIR

u.m.vta: 1  20

Rubio claro · Light blond

Junior

REF. 06342

- Implantación natural
- Para corte, peinado, permanente y coloración
- *Natural insertion*
- *For cutting, styling, permanent and coloring*

Rubio · Blond

Teeny

REF. 06344

- Implantación natural
- Para corte y coloración
- *Natural insertion*
- *For cutting and coloring*



Soporte no incluido
 Not included support



Soporte no incluido
 Not included support



Soportes cabeza maniquí
Mannequin head holders

u.m.vta: 1  25

REF. 00983

- Plástico
- Plastic





u.m.vta: 1  50

REF. 01461

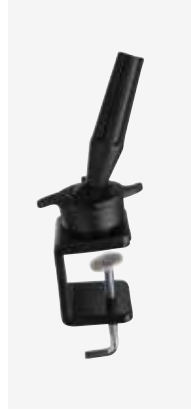
- Plástico
- Plastic





u.m.vta: 1  100 

REF. 06276

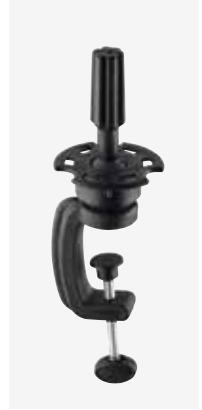
- Plástico
- Plastic



u.m.vta: 1  10 

REF. 06162

- Plástico
- Plastic



u.m.vta: 1  12

REF. 03625

- Aluminio
- Aluminum



Soporte trípode cabeza maniquí de aluminio
Aluminum mannequin head tripod holder

u.m.vta: 1  10

REF. 03738

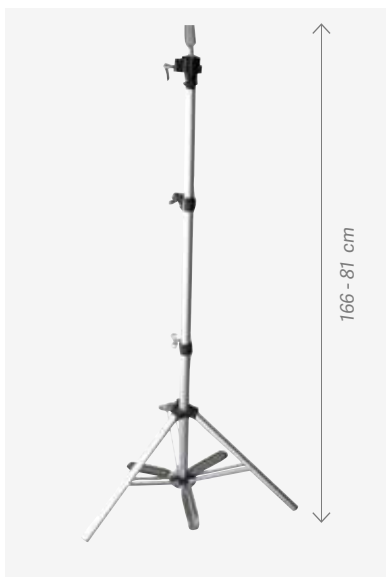

u.m.vta: 1  6

REF. 03624



u.m.vta: 1  6 

REF. 01841

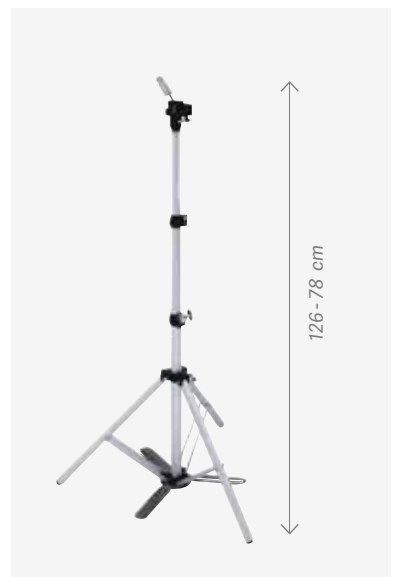



07

Mobiliario Furniture

*Tocadores, sillas, lavacabezas,
estanterías, carritos...*

*Dressers, chairs, wash basin,
shelves, trolleys...*

Mostrador para recepción de madera y metal efecto espejo
Wood and metal reception desk with mirror effect

u.m.vta: 1  1

REF.03935

Con compartimentos interiores de madera para almacenaje y repisa
 With a shelf and interior wooden compartments for storage



Recepción EARTH
EARTH reception

u.m.vta: 1  1

Grafito · Graphite



REF.04518/50

Roble · Oak



REF.04518/65

Blanco · White



REF.04518/58

- Laminado
- Con estantes regulables y 1 cajón

- Laminated
- With adjustable shelves and 1 drawer



Espejo tocador doble Double dressing table mirror

u.m.vta: 1  1

- Con armario, mesa y reposapiés
- With a cupboard, table and footrest

REF.03949



Sofa espera 3 plazas 3 seater waiting sofa

u.m.vta: 1  1

- En polipiel
- In black imitation leather

REF.03950



Tocador mural MERCURY MERCURY wall dressing table

u.m.vta: 1  1

● Grafito · Graphite
REF.04517/50

○ Blanco · White
REF.04517/58

● Roble · Oak
REF. 04517/65



Espejo rectangular LIGHT LIGHT rectangular mirror

u.m.vta: 1  1

REF.06099



- Laminado
- Con estante, con soporte para secador y apoyapiés cromado incorporado
- Laminated
- With shelf with support for dryer and built-in chrome footrest

Espejo rectangular unisex, elegante y sofisticado. Contiene una gran superficie de espejo. Incluye un estante para apoyar los objetos que desee, así como un cómodo reposapiés.

Elegant and sophisticated unisex rectangular mirror with large mirror surface. Includes a shelf to rest the objects you want, in addition to a comfortable footrest.

Sillas para niños

Children seats

u.m.vta: 1  1

Sillas para niños de gran calidad, fabricadas en metal y con un estilo vintage para que la experiencia de ir a la peluquería sea agradable para los niños. Coches a pedales que funcionan si se desmontan del soporte. Luces decorativas y cinturón de seguridad. Además, si se gira el volante, se mueven las ruedas delanteras. No contiene claxon.

High-quality children seats made from metal in a vintage style to make the trip to the hairdressing's a pleasant and drama-free experience. Pedal cars that function when detached from their base. Decorative lights and seat belt. Moreover, if you turn the steering wheel, the front wheels move. Do not have horn.



24 kg

REF.04728



26,8 kg

REF.04727



Silla especial para niños Special children's seats

u.m.vta: 1  1

REF.02733



Cojines especiales para niños Special cushions for kids

u.m.vta: 1  2

REF.07329/50



Cojines especiales para niños Special cushions for kids

u.m.vta: 1  1

REF.03939

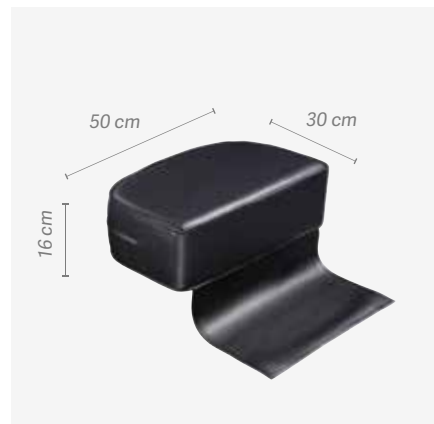

Cojines especiales para niños Special cushions for kids

u.m.vta: 1  1

● REF.04506/50 ● REF.04506/60

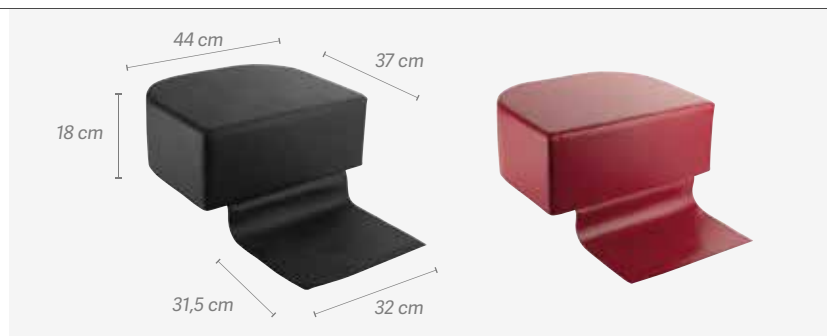

Cojines especiales aptos para cualquier sillón de peluquería. Permiten un trabajo más cómodo al profesional, ya que elevan al niño a la altura idónea.

Special cushions that are suitable for all kinds of hairdressing's seats, allowing professionals to work more comfortably by placing children to the ideal height.

Taburete STREET
STREET stool

u.m.vta: 1  1



SCAN ME!



REF.06103/50



REF.06103/58



Comparativa
04419 - 06103
Comparative
04419 - 06103



El taburete STREET clásico contiene una bomba hidráulica que permitirá regular la altura a la deseada del profesional, facilitando su trabajo.

STREET classic stool contains a hydraulic bomb that will allow regulate the height desired of the professional, helping its work.

Taburete base metal
Stool metallic base

u.m.vta: 1  1



SCAN ME!



REF.04419/50



REF.04419/58



Taburete RODEO
RODEO stool

u.m.vta: 1  1

REF.01964



Taburete URBAN

URBAN stool

u.m.vta: 1  1SCAN
ME!

REF.06102/50



REF.06102/58



Comparativa
04382 - 06102
Comparative
04382 - 06102



Taburete URBAN ergonómico con bomba hidráulica, para regular la altura a la deseada en cada trabajo. Su forma se adapta al cuerpo y como consecuencia propicia una mejor postura y evita los dolores de espalda después de muchas horas de trabajo.

URBAN stool ergonomic with hydraulic pump to regulate the height to the desired one in each work. Its ergonomic shape adapts to the shape of the body and as a consequence a better posture of the back that can avoid pain after many hours of work.

Taburete RODEO base metal

RODEO metallic base stool

u.m.vta: 1  1SCAN
ME!

REF.04382/50



REF.04382/58



Reposapiés metal

Metal footrest

u.m.vta: 1  1

Recto
Straight

REF.04384

u.m.vta: 1  1

Curvo
Curved

REF.02838



Silla con respaldo y regulación
Backed chair with height adjustment

u.m.vta: 1  1



REF.02730/58



Silla con regulación
Chair with height adjustment

u.m.vta: 1  1



REF.02732



REF.02732/58



Silla con respaldo y regulación
Backed chair with height adjustment

u.m.vta: 1  1



REF.03937/50



REF.03937/58

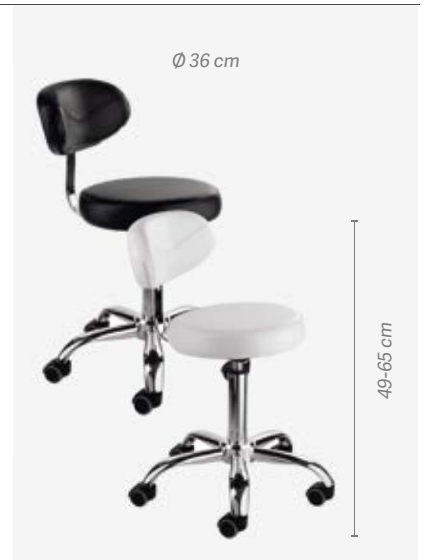

Silla con respaldo FASHION
FASHION backed chair

u.m.vta: 1  1



REF.06101/58



SCAN
ME!

Silla FASHION con respaldo para más comodidad y apoyo de la espalda. Las ruedas están diseñadas para evitar que el cabello se quede enganchado en ellas. Son fáciles de limpiar.

FASHION backed chair for more comfort and support of the back. The wheels are designed to prevent the hair from getting caught in them. They are easy to clean.



Lavacabezas GLAMOUR

GLAMOUR wash basin chair

u.m.vta: 1  1

REF.07191

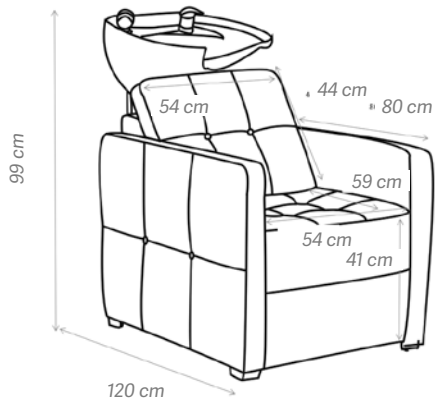

Nuevo lavacabezas GLAMOUR de EUROSTIL. Con diseño de líneas rectas y modernas pero con la máxima comodidad. Provisto de una teja de cerámica ergonómica y reclinable.

New GLAMOUR wash basin. A straight-line design with maximum comfort. Supplied with an ergonomic and adjustable ceramic basin.

Lavacabezas OVAL

OVAL wash basin chair

u.m.vta: 1  1

REF.07195

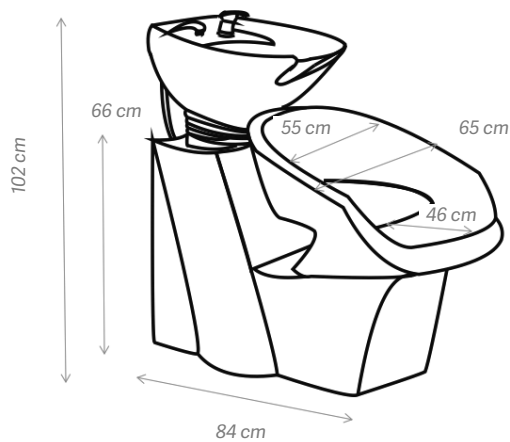

Nuevo lavacabezas OVAL de EUROSTIL. Diseño de líneas rectas y modernas pero con la máxima comodidad. Provisto de una teja de cerámica ergonómica y reclinable.

New OVAL wash basin. A straight-line design with maximum comfort. Supplied with an ergonomic and adjustable ceramic basin.

Lavacabezas KURVA

KURVA wash basin chair

u.m.vta: 1  1

REF.07193

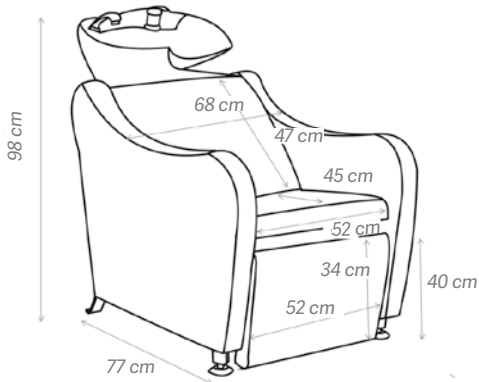

Nuevo lavacabezas KURVA de EUROSTIL. Diseño de líneas rectas y modernas pero con la máxima comodidad. Provisto de una teja de cerámica ergonómica y reclinable.

New KURVA wash basin. A straight-line design with maximum comfort. Supplied with an ergonomic and adjustable ceramic basin.



Lavacabezas KVADRAT

KVADRAT wash basin chair

u.m.vta: 1  1

REF.07197

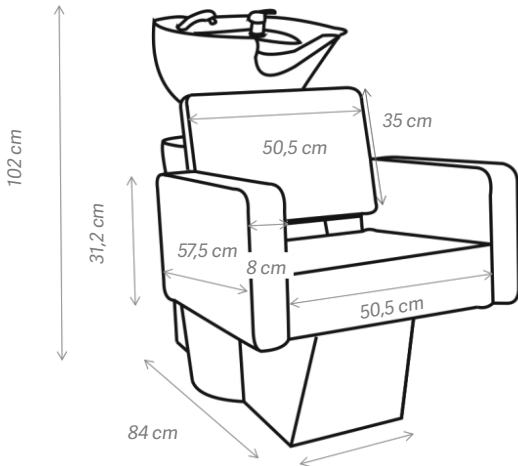

Nuevo lavacabezas KVADRAT de EUROSTIL. Diseño de líneas rectas y modernas pero con la máxima comodidad. Provisto de una teja de cerámica ergonómica y reclinable.

New KVADRAT wash basin. A straight-line design with maximum comfort. Supplied with an ergonomic and adjustable ceramic basin.



Ref. 07197

Ref. 07196

Lavacabezas PIN UP

PIN UP wash basin chair

u.m.vta: 1  1

REF.06476/70



Debido a la espuma del tapizado, las medidas pueden tener una pequeña variación alrededor de 1 cm aproximadamente.

Due to the upholstery foam, the measurements may have a small variation about 1 cm approximately.



Lavacabezas STIL

STIL wash basin chair

u.m.vta: 1  1 

Reclinable
Reclining



REF. 02841



REF. 02841/54



REF. 02841/58

u.m.vta: 1  1

NEW

REF. 07484

No Reclinable
No Reclining



- Apoyabrazos y mando cromados
- Teja de cerámica y base fibra de vidrio
- Asiento deslizante
- Largo base 76 cm
- Anchura asiento 48 cm
- Alto respaldo 41 cm
- Cerámica 57 x 50 x 20 cm
- Altura total 95 cm

- Chromed arm rests and controller
- Ceramic tile and fibreglass base
- Sliding seat
- Base length 76 cm
- Seat width 48 cm
- Backrest height 41 cm
- Ceramic tile 57 x 50 x 20 cm
- Total height 95 cm

Lavacabezas NEPTUNO

NEPTUNO wash basin

u.m.vta: 1  1

- Estructura en acero y madera
- Cerámica blanca basculante
- Asiento fijo
- Monomando de ducha negro

- Steel and wood structure
- Sliding white ceramic
- Fixed seat
- Black shower mixer



Lavacabezas VENUS

VENUS wash basin

u.m.vta: 1  1

- Estructura de polietileno
- Cerámica blanca basculante
- Asiento fijo
- Monomando de ducha negro

- Polyethylene structure
- Sliding white ceramic
- Fixed seat
- Black shower mixer



Separador lavacabezas VENUS negro

VENUS black wash basin link unit

u.m.vta: 1  1

REF.04515



Lavacabezas ART

ART wash basin

u.m.vta: 1	 1
------------	---

REF.06097/50 Reclinable
Reclining

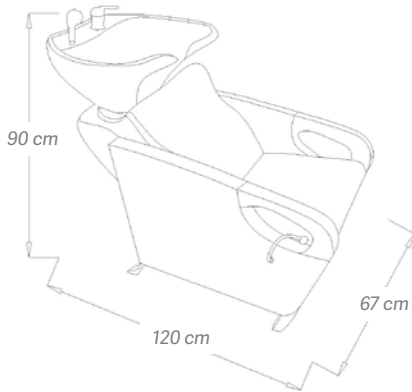

El nuevo lavacabezas ART tiene un diseño con líneas curvas, en color negro y con acabados en plata, pensado para dar la máxima comodidad al cliente mientras se le lava el cabello. Está compuesto por una pica de cerámica honda, ergonómica, reclinable en la zona de los pies y adaptable a cada servicio. Junto con la silla ART hacen el conjunto ideal para su salón.

The new ART wash basin has a design with curved lines, in black color and with silver finishes, but at the same time it is designed to give the maximum comfort to the customer while washing the hair. It is composed of a ceramic sling, deep, ergonomic, reclining in the area of the feet and adaptable to each service. Together with the ART chair they make the ideal set for your salon.

Lavacabezas MOOD

MOOD wash basin

u.m.vta: 1	 1
------------	---

REF.06098/50 Reclinable
Reclining

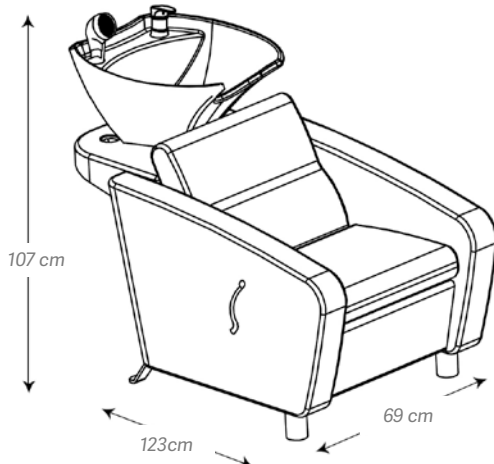

El nuevo lavacabezas MOOD tiene un diseño con líneas curvas, pensado para dar la máxima comodidad al cliente mientras se le lava el cabello. Está compuesto por una pica de cerámica honda, ergonómica, reclinable en la zona de los pies y adaptable a cada servicio.

The new MOOD wash basin has a design with curved lines, but at the same time it is designed to give maximum comfort to the customer while washing their hair. It is composed of a ceramic sling, deep, ergonomic, reclining in the area of the feet and adaptable, to each service.

Silla de peluquería GLAMOUR GLAMOUR hairdressing chair

u.m.vta: 1  1

REF.07190

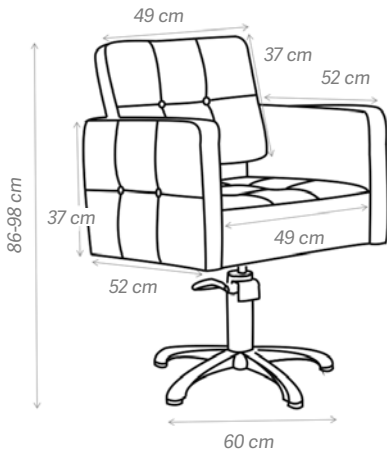

Nueva silla de peluquería GLAMOUR de Eurostil. Con diseño de líneas rectas y modernas, pero con la máxima comodidad. Ajustable en altura gracias a su bomba hidráulica.

New GLAMOUR hairdressing chair. A straight-line design with maximum comfort. Adjustable in height thanks to its hydraulic pump.

Silla de peluquería KURVA KURVA hairdressing chair

u.m.vta: 1  1

REF.07192

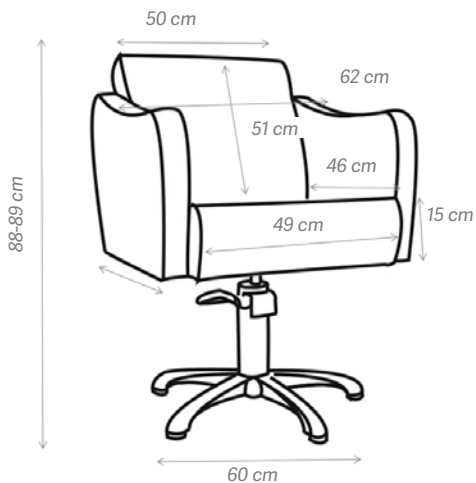

Nueva silla de peluquería KURVA de Eurostil. Con diseño de líneas rectas y modernas, pero con la máxima comodidad. Ajustable en altura gracias a su bomba hidráulica.

New KURVA hairdressing chair. A straight-line design with maximum comfort. Adjustable in height thanks to its hydraulic pump.

Silla de peluquería OVAL

OVAL hairdressing chair

u.m.vta: 1  1

REF.07194

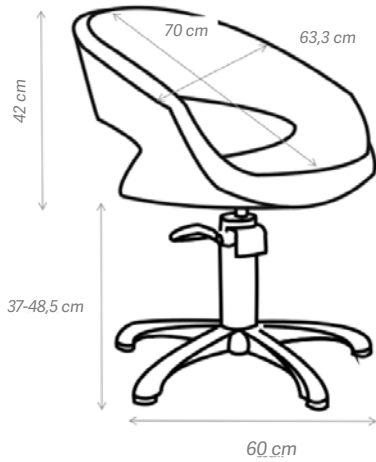

Nueva silla de peluquería OVAL de Eurostil. Con diseño de líneas rectas y modernas, pero con la máxima comodidad. Ajustable en altura gracias a su bomba hidráulica.

New OVAL hairdressing chair. A straight-line design with maximum comfort. Adjustable in height thanks to its hydraulic pump.



Silla de peluquería KVADRAT KVADRAT hairdressing chair

u.m.vta: 1  1

REF.07196

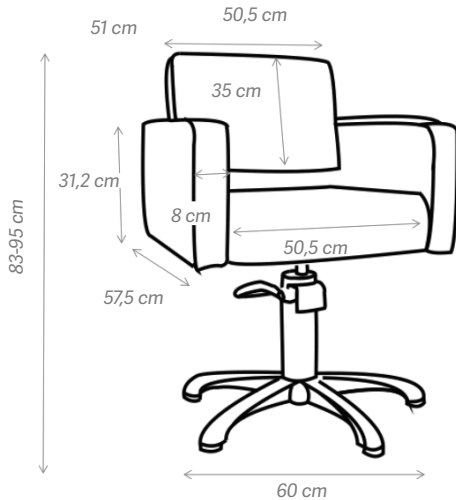

Nueva silla de peluquería KVADRAT de Eurostil. Con diseño de líneas rectas y modernas, pero con la máxima comodidad. Ajustable en altura gracias a su bomba hidráulica.

New KVADRAT hairdressing chair. A straight-line design with maximum comfort. Adjustable in height thanks to its hydraulic pump.

Silla de peluquería PIN UP ROSA PINK PIN UP hairdressing chair

u.m.vta: 1  1

REF.06477/70

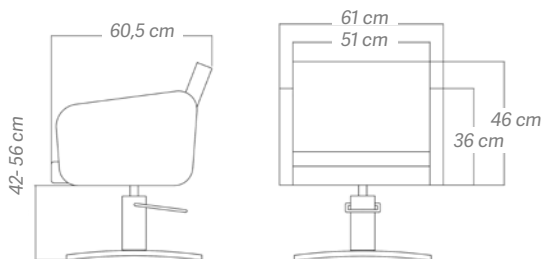

La nueva silla PIN UP tiene un diseño con líneas modernas, pensadas para dar la máxima comodidad. La silla consta de una bomba hidráulica que permite subir y bajar el asiento, para que pueda situar al cliente a la altura que se adapte mejor a cada trabajo.

The new PIN UP chair has a design of modern lines, but at the same time it's designed to give maximum comfort. The chair has a hydraulic pump that allows to lift and lower the seat, so we can place our client in the best spot for each to work.

Sillón STRATOS

STRATOS chair

u.m.vta: 1



u.m.vta: 1



REF.02840/54



REF. 02840

- Con reposapiés
- Elevación hidráulica
- Respaldo: 52 x 45 cm
- Anchura brazo a brazo: 50 cm
- Base asiento: 48 cm
- Brazos cromados



REF.02840/60

- Includes a footrest
- Hydraulic elevation system
- Back rest 52 x 45 cm
- Arm to arm width 50 cm
- Seat 48 cm
- Chromed arm rests



REF.02840/59



Sillón hidráulico VENUS NEGRO

VENUS black hydraulic chair

u.m.vta: 1



REF.04513/50



REF.04513/58



REF.04513/62



REF.04513/64



REF.04513/65



REF.04513/69



REF.04513/72

- Base estrellada de aluminio
- Elevación hidráulica
- Tapizado en negro
- Ancho: 58 cm
- Profundidad: 64 cm
- Altura elevación asiento: 45 cm – 60,5 cm

- Aluminum star base
- Hydraulic lift
- Upholstered in black
- Width: 58 cm
- Depth: 64 cm
- Seat lift height: 45 cm - 60.5 cm



Silla de peluquería CHIC

CHIC hairdressing chair

u.m.vta: 1  1

SCAN
ME!

* Con reposapiés
* With footrest

REF.06096/50/2 REF.06096/50/5*

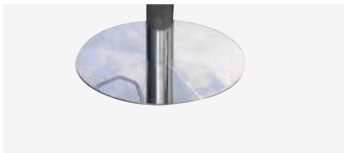

REF.06096/50/3 REF.06096/50/6*

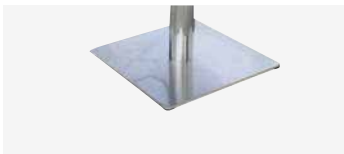

REF.06096/50/1 REF.06096/50/4*

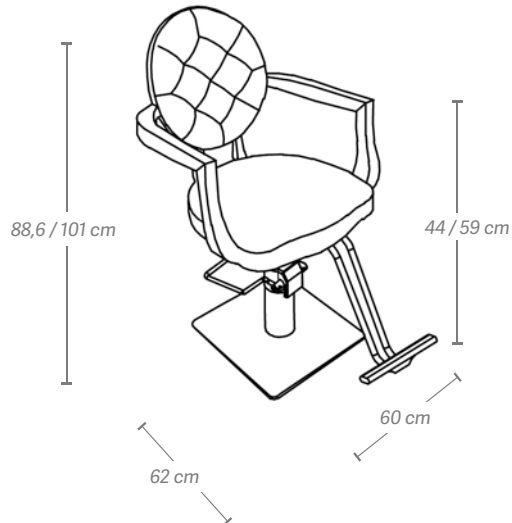
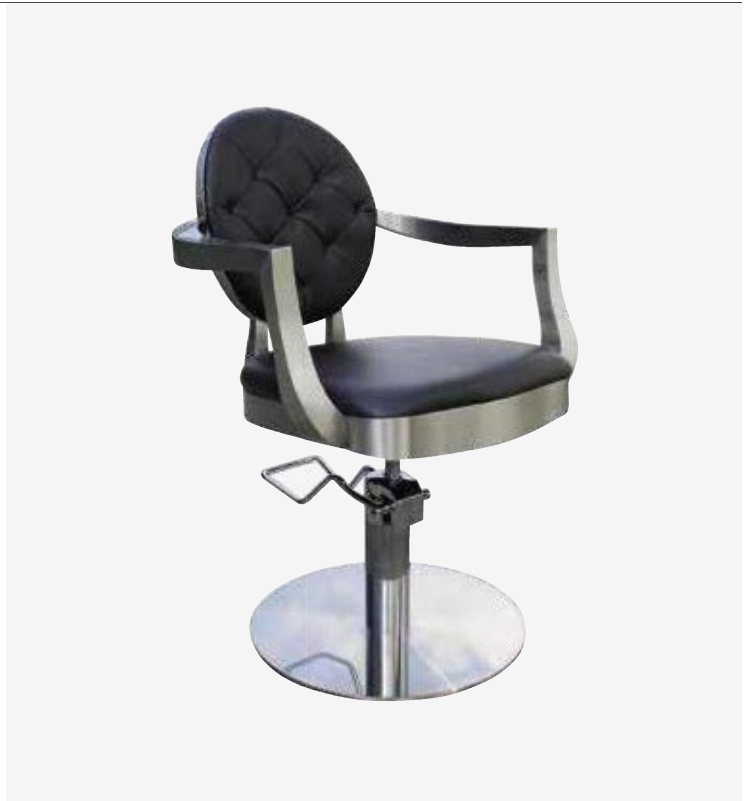

La silla de peluquería CHIC tiene un diseño clásico que combina líneas rectas y curvas, pensadas para dar la máxima comodidad. La silla consta de una bomba hidráulica que permite subir y bajar el asiento, para que pueda situar al cliente a la altura que se adapte mejor a cada trabajo. Combinable con 3 pies y con la opción de reposapiés.

The CHIC hairdressing chair has a classic design that combines curved and straight lines, designed to give maximum comfort. The chair has a hydraulic pump that allows you to raise and lower the seat, so you can place the customer to the height that best suits each job. Combinable with 3 feet, and with the option of footrest.

Silla de peluquería STYLE

STYLE hairdressing chair



SCAN
ME!

* Con reposapiés
* With footrest

REF.06095/50/2 REF.06095/50/5*

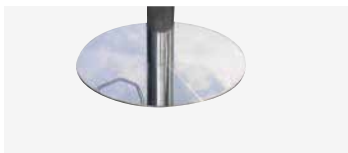

REF.06095/50/3 REF.06095/50/6*

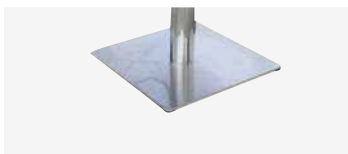

REF.06095/50/1 REF.06095/50/4*

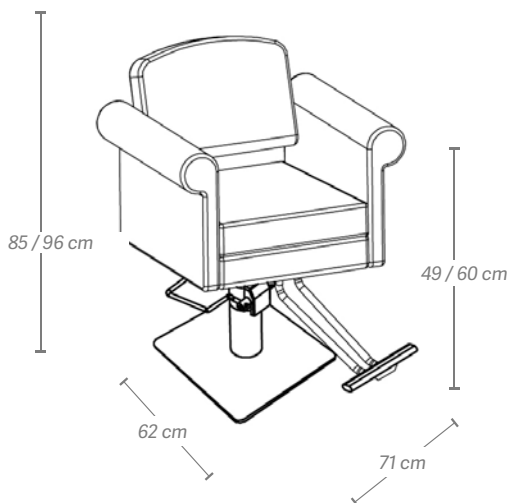

La silla de peluquería STYLE tiene un diseño vintage que combina líneas curvas, en color negro y con las costuras blancas, pensadas para dar la máxima comodidad. La silla consta de una bomba hidráulica que permite subir y bajar el asiento, de esta forma podrá situar al cliente a la altura que se adapte mejor a cada trabajo. Combinable con 3 pies y con la opción de reposapiés.

The STYLE hairdressing chair has a vintage design that combines curved lines, in black and with white finishes, designed to give maximum comfort. The chair has a hydraulic pump that allows you to raise and lower the seat, so you can place the customer to the height that best suits each job. Combinable with 3 feet, and with the option of footrest.

Silla de peluquería BOHEMIAN
BOHEMIAN hairdressing chair

u.m.vta: 1  1



* Con reposapiés
 * With footrest

REF.06093/50/2 REF.06093/50/5*



REF.06093/50/3 REF.06093/50/6*

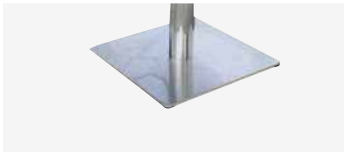

REF.06093/50/1 REF.06093/50/4*



89 / 104 cm



La silla de peluquería BOHEMIAN tiene un diseño actual que combina líneas curvas y rectas, en color negro y con acabados en plata, pensada para dar la máxima comodidad. La silla consta de una bomba hidráulica para que pueda subir y bajar el asiento, y situar al cliente a la altura que se adapte mejor a cada trabajo. Combinable con 3 pies y con la opción de reposapiés.

The BOHEMIAN hairdressing chair has a current design that combines curved and straight lines, in black color and with silver finishes, designed to give maximum comfort. The chair has a hydraulic pump that allows you to raise and lower the seat, so you can place the customer to the height that best suits each job. Combinable with 3 feet, and with the option of footrest.

Silla de peluquería ART ART hairdressing chair

u.m.vta: 1  1



SCAN
ME!

* Con reposapiés
* With footrest

REF.06094/50/2 REF.06094/50/5*

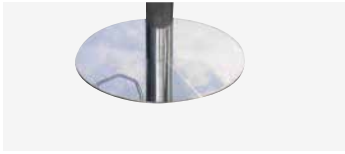

REF.06094/50/3 REF.06094/50/6*

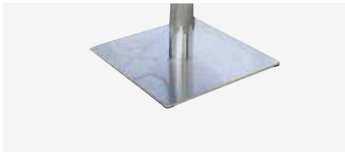

REF.06094/50/1 REF.06094/50/4*

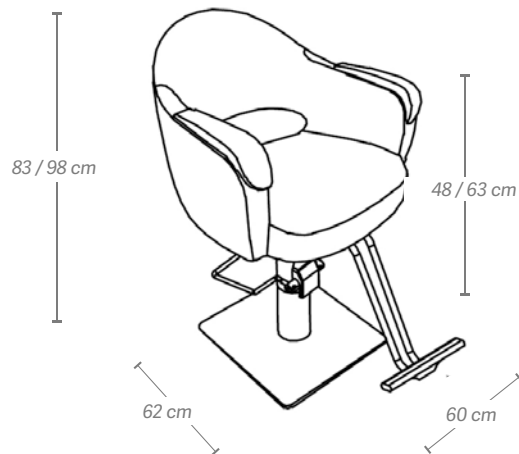



La silla de peluquería ART tiene un diseño moderno que combina líneas curvas, en color negro y con acabados en plata, pensada para dar la máxima comodidad. La silla consta de una bomba hidráulica que permite subir y bajar el asiento, para que pueda situar al cliente a la altura que se adapte mejor a cada trabajo. Combinable con 3 pies y con la opción de reposapiés.

The ART hairdressing chair has a modern design that combines curved lines, in black color and with silver finishes, designed to give the maximum comfort. The chair has a hydraulic pump that allows you to raise and lower the seat, so you can place the customer to the height that best suits each job. Combinable with 3 feet, and with the option of footrest.

Lavacabezas portátil con pie y desagüe

Portable wash basin with support and drain

u.m.vta: 1  1 

 REF. 03736  REF. 03736/68  REF. 03736/54

- Con pie y desagüe.
- *Con hueco para champús.
- Basculante.

- With support and drain.
- *With hole for shampoos.
- Floating.



*Detalle apoya champús
*Detail supports shampoos



Lavacabezas portátil

Portable wash basin

u.m.vta: 1  1

REF.01970

- Pie regulable en altura
- Desagüe: 50 cm
- No basculante

- Base with adjustable height
- Drain: 50 cm
- Non-sliding



Depósito para lavacabezas

Water container for wash basin

u.m.vta: 1  5

11,5 L

REF.03737



Apto para estos modelos
Fit for these Models





Lavacabezas portátil hinchable Portable inflatable wash basin

u.m.vta: 1  20

REF.03923

SCAN
ME!

Lavacabezas portátil Portable wash basin

u.m.vta: 1  12 

REF. 04838/50

REF. 04838/70

REF. 04838/54



Lavacabezas portátil con soporte respaldado para sillas Portable blackwash with backrest for chairs

u.m.vta: 2  2SCAN
ME!

Lavacabezas compuesto de una teja realizada en material muy ligero, fácil de montar, ajustable en altura y muy práctico para realizar la higiene del cabello a personas con poca movilidad o para servicios a domicilio.

A backwash composed of a tile made of very lightweight material, easy to assemble, adjustable in height and very practical, ideal for performing hair hygiene to people with limited mobility or for home services.

REF.06952

Lavacabezas Eurostil portátil con enganche en respaldo
Eurostil portable headrest with back hitch

REF.06952/00

Lavacabezas portátil con enganche en respaldo. Anónimo
Portable headrest with back hitch. Anonymous

u.m.vta: 2  2

REF.RE06952/04

REF.RE06952/04/00

REF.RE06952/05

Caja 2 bandejas Eurostil
Box of 2 Eurostil trays

Caja 2 bandejas anónimas
Box of 2 anonymous trays

Caja de 2 enganches para respaldo
Box of 2 hooks for the backrest

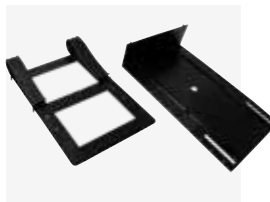

Carrito auxiliar Auxiliary trolley

u.m.vta: 1  1

Gio

REF.02366/50

Jolly

REF.00874

Black

REF.03215



Mesa auxiliar regulable Adjustable auxiliary table

u.m.vta: 1  1

REF.03843

- Con plato de acero inoxidable

- With stainless steel plate



Carrito 2 bandejas para tintura Trolley 2 trays for dyeing

u.m.vta: 1  1

REF.03181

- Carrito especial para todo tipo de trabajos de tintura y decoloración
- Con capacidad para varias cocteleras, boles y un alojamiento especial para el papel de aluminio necesario para las mechas
- Ligero y muy manejable
- Con ruedas giratorias para un mejor desplazamiento

- Special trolley for carrying out all sorts of dyeing and bleaching work
- It has the space to hold several shakers and bowls, and it has a special container for the aluminium foil required to do highlights
- Lightweight and very manageable
- Swivel wheels to make it easier to move



Carrito de madera SWING SWING wooden trolley

u.m.vta: 1	 1
------------	---

Carrito con dos cuerpos negros y 3 cajones respectivamente (6 en total). Consta de 4 ruedas para ser más cómodo a la hora de desplazarlo. La bandeja superior tiene mucho espacio y contiene varios huecos pensados para depositar distintos objetos. También incluye un soporte metálico para apoyar el secador.

A trolley with two black bodies and 3 drawers respectively (6 in total). With 4 wheels to make moving it more manageable. The upper tray is very spacious and has several partitions for easy storage. It also includes a metal holder for the hair dryer.

Carrito para tintura Dyeing trolley

u.m.vta: 1	 1
------------	---

- Carrito especial para todo tipo de trabajos de tintura y decoloración
- Con capacidad para varias paletinas, cocteleras, boles y dos alojamientos especiales para el papel de aluminio
- Ligero y muy manejable
- Con ruedas giratorias para un mejor desplazamiento

- *Special trolley for carrying out all sorts of dyeing and bleaching work*
- *It has the space to hold several palettes, shakers and bowls, as well as two special containers for aluminium foil*
- *Lightweight and very manageable*
- *Swivel wheels to make it easier to move*

REF.06279



REF.03180



Carrito peluquería MASTER UP MASTER UP hairdressing trolley

u.m.vta: 1	 1
------------	---

REF.01963/50



Carrito peluquería Hairdressing trolley

u.m.vta: 1  1

Mod. Boy
REF.00877

Mod. Smile
REF.04380

Mod.Funny
REF.04381



Contenedor toallas Towels container

u.m.vta: 1  4

REF.03159



- Con ruedas
- Bolsa contenedora lavable
- Estructura de acero inoxidable

- Features wheels
- Washable containing bag
- Stainless steel structure

Organizador para colgar toallas
Organizer to hang towels

u.m.vta: 1  6

REF.04378

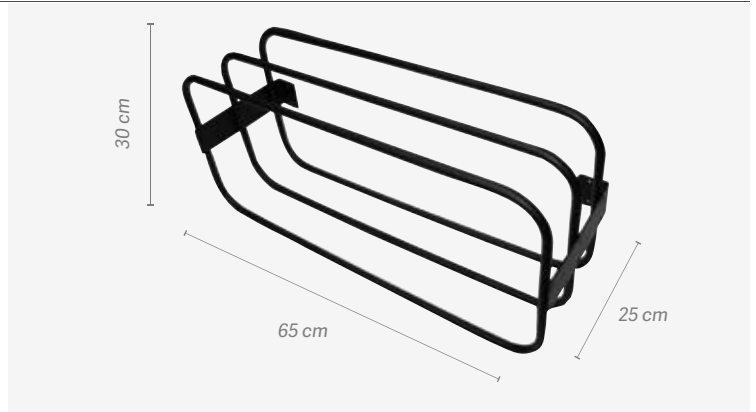

Ducha con soporte
Shower tap with support

u.m.vta: 1  20

REF.03004



Juego ducha adaptable
Shower adaptable

u.m.vta: 1  10

REF.01960



Monomando para lavacabezas
Mix taper for wash basin

u.m.vta: 1  50

REF.02837



Cabezal ducha iónico
Ionic shower head

u.m.vta: 1  36

REF.03750

Ahorro agua
 Mejor calidad de agua

Saving water
 Better water quality



Conjunto monomando y ducha para lavacabezas
Single-lever mixer and shower for wash basin

u.m.vta: 1  12

REF.07618

NEW



Ducha con soporte lavacabezas
Shower with wash basin support

u.m.vta: 1  12

REF.07619

NEW



Cabezal de ducha cromado
Chrome shower head

u.m.vta: 1  12

REF.07620

NEW



Ducha lavacabezas negro
Black shower wash basin

u.m.vta: 1  12

REF.07625

NEW



Válvula fregadero lavacabezas
Wash basin sink valve

u.m.vta: 1  12

REF.07626

NEW



Reductor de flujo de agua
Water flow reducer

u.m.vta: 1  12

NEW

REF.07623



Tubo desague lavacabezas hasta 80 cm
Wash basin drain pipe up to 80 cm

u.m.vta: 1  12

NEW

REF.07624



Tubo flexible pvc ducha 120 cm para lavacabezas
PVC flexible shower hose for wash basin

u.m.vta: 1  12

REF.07621



120 cm



NEW

Tubo flexible nylon ducha para lavacabezas
Flexible nylon shower tube for wash basin

u.m.vta: 1  12

REF.07781



120 cm



NEW



08

Peines y cepillos Combs and brushes

*Cepillos, cepillos térmicos, peines,
estuches peluquero, expositores...*

*Hair brushes, thermal hair brushes,
combs, hairdresser cases, displays...*

Cepillo crear
Teasing brushes

u.m.vta: 12  70

REF.00105/50



Púas de nylon
Nylon bristles

u.m.vta: 12  60

REF.02452



Cerdas de jabalí
Boar bristles

u.m.vta: 12  60

REF.04528

3 hileras de pelo, la hilera central más alta
3 lines of hair, the central line is the highest



Cerdas de jabalí
Boar bristles

u.m.vta: 12  60

REF.00106



u.m.vta: 12  70

REF.00106/58



Púas de nylon
Nylon bristles

u.m.vta: 12  60

REF.03171



u.m.vta: 12  60

REF.03171/58



Cerdas de jabalí
Boar bristles

u.m.vta: 12  60

REF.03880



u.m.vta: 12  50

REF.03880/58



Púas de plástico
Plastic bristles

u.m.vta: 12  48

REF.03227

Cepillo de madera.
Cuerpo curvado para mejor adaptación
Wooden brush. It has a curved shape for better adaptation



Cerdas de jabalí
Boar bristles

u.m.vta: 12  120



REF.00161



Púas de metal con bola
Metal bristles with ball

Cepillos espiral con mango de plástico



Spiral brushes with plastic handle

u.m.vta: 1  50 

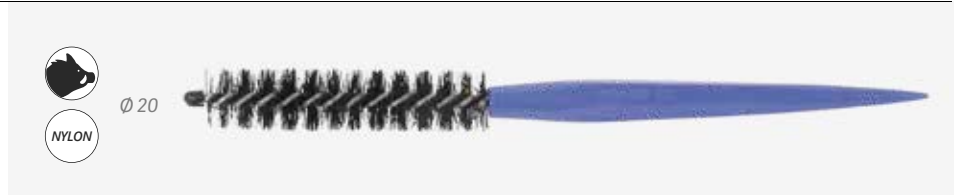
REF. 01851



Cerdas de nylon + jabalí
Nylon bristles + boar

u.m.vta: 1  40 

REF. 01598



Cerdas de nylon + jabalí
Nylon bristles + boar

u.m.vta: 1  12 



REF. 02995



Cerdas de jabalí
Boar bristles

Cepillos espiral con mango de madera



Spiral brushes with wooden handle

u.m.vta: 1  30 

REF. 00502



Cerdas de nylon + jabalí
Nylon bristles + boar

u.m.vta: 1  30 

REF. 01597



Cerdas de nylon + jabalí
Nylon bristles + boar

Cepillo circular de madera
Circular wooden brush

Púas de nylon
Nylon bristles



u.m.vta: 1 12

Ø 30

REF. 00758

u.m.vta: 1 20

Ø 18

REF. 00503

u.m.vta: 1 16

Ø 24

REF. 00110

u.m.vta: 1 18

Ø 12

REF. 01590

u.m.vta: 1 20

Ø 15

REF. 00504

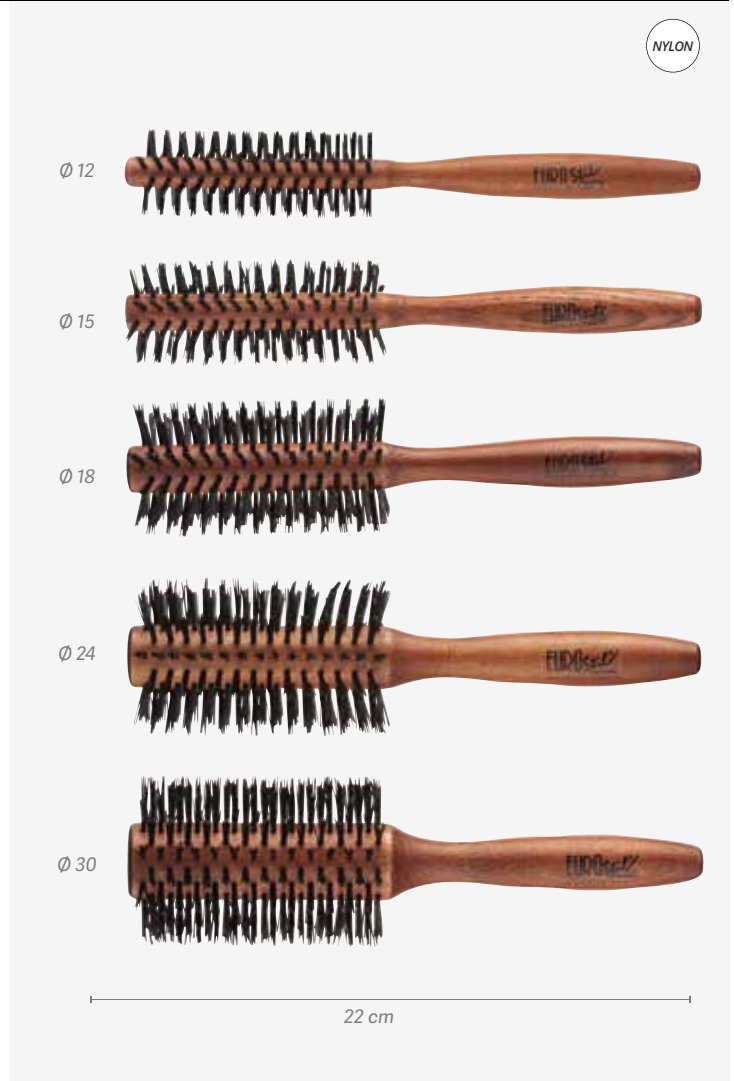

Cepillo circular de plástico JUMBO
Circular plastic brush JUMBO

u.m.vta: 1 6

REF. 02178

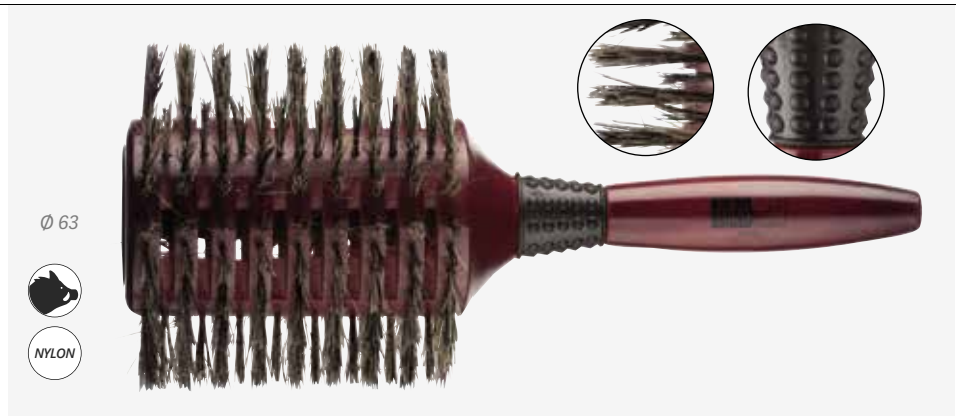

Cepillo circular de madera
Circular wooden brush

Púas de nylon + jabalí
Nylon bristles + boar

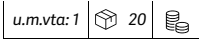
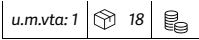

Ø 12

Ø 15

REF. 01591

REF. 00511

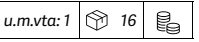
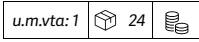

Ø 18

Ø 24

REF. 00513

REF. 01594



¿Quieres saber más?
Do you want to know more?

SCAN ME!

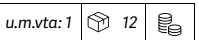
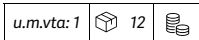

Ø 30

Ø 45

REF. 00756

REF. 00596

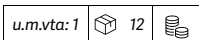

Ø 38

Ø 38

Cerdas cortas
Short bristles

Cerdas largas
Large bristles

REF. 00589

REF. 00588

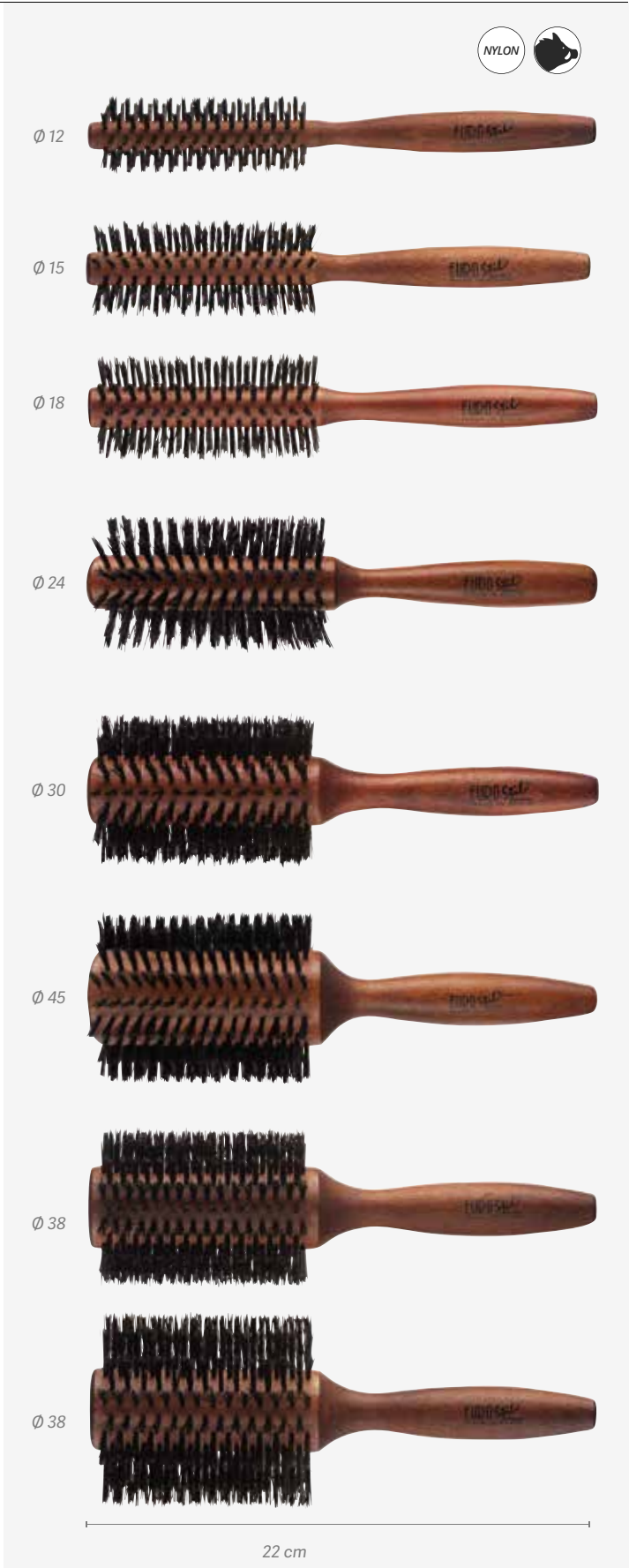

Ø 12

Ø 15

Ø 18

Ø 24

Ø 30

Ø 45



Ø 38

Ø 38

22 cm

Cepillo circular de madera
Circular wooden brush

Púas de nylon + bola
Nylon bristles + ball

u.m.vta: 1  12 

∅ 9
REF. 00505

∅ 15
REF. 00163

∅ 23
REF. 00165



Cepillo circular de madera
Circular wooden brush

Cerdas de jabalí
Boar bristles



u.m.vta: 1  24

∅ 12
REF. 00346

u.m.vta: 1  24

∅ 14
REF. 00347

u.m.vta: 1  24

∅ 18
REF. 00348

u.m.vta: 1  18

∅ 22
REF. 00349

u.m.vta: 1  18

∅ 33
REF. 00350

u.m.vta: 1  12

∅ 45
REF. 00367



Cepillo circular de madera con mango de goma
Circular wooden brush with rubber handle

Púas de nylon + jabalí
 Nylon bristles + boar



u.m.vta: 1 16

Ø 15

REF. 03126

u.m.vta: 1 16

Ø 18

REF. 03127

u.m.vta: 1 12

Ø 24

REF. 03128

u.m.vta: 1 12

Ø 30

REF. 03129

u.m.vta: 1 12

Ø 38

REF. 03130



Cepillo con fuelle y mango madera
Cushion brush with wooden handle

Púas de nylon + jabalí
 Nylon bristles + boar

u.m.vta: 1 12 12

REF. 00529

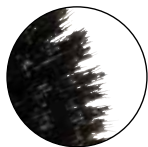

REF. 00528



Cepillo con fuelle y mango de madera
Cushion brush with wooden handle

Cerdas de jabalí
 Boar bristles

u.m.vta: 1  12 

REF. 00325

REF. 00326

REF. 00352

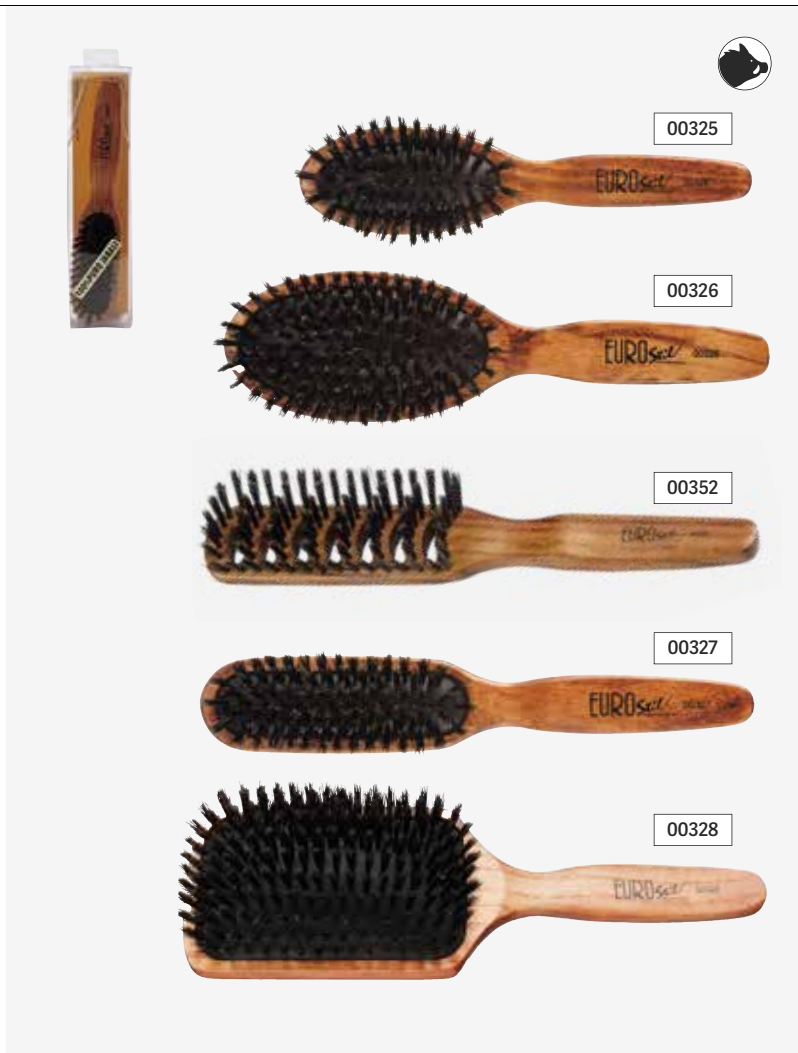

REF. 00327

REF. 00328



Cepillo con fuelle y mango madera
Cushion brush with wooden handle

Púas de metal con bola
 Metal bristles with ball

u.m.vta: 1  12 

REF. 00146



REF. 00148

REF. 00147



Cepillo con fuelle y mango de madera
Cushion brush with wooden handle

Púas de plástico
 Plastic bristles

u.m.vta: 12  12

REF.03299





u.m.vta: 12  12



REF.03298

u.m.vta: 12  120

REF.00597

u.m.vta: 12  120 

REF. 01994

u.m.vta: 12  96 

REF. 00590

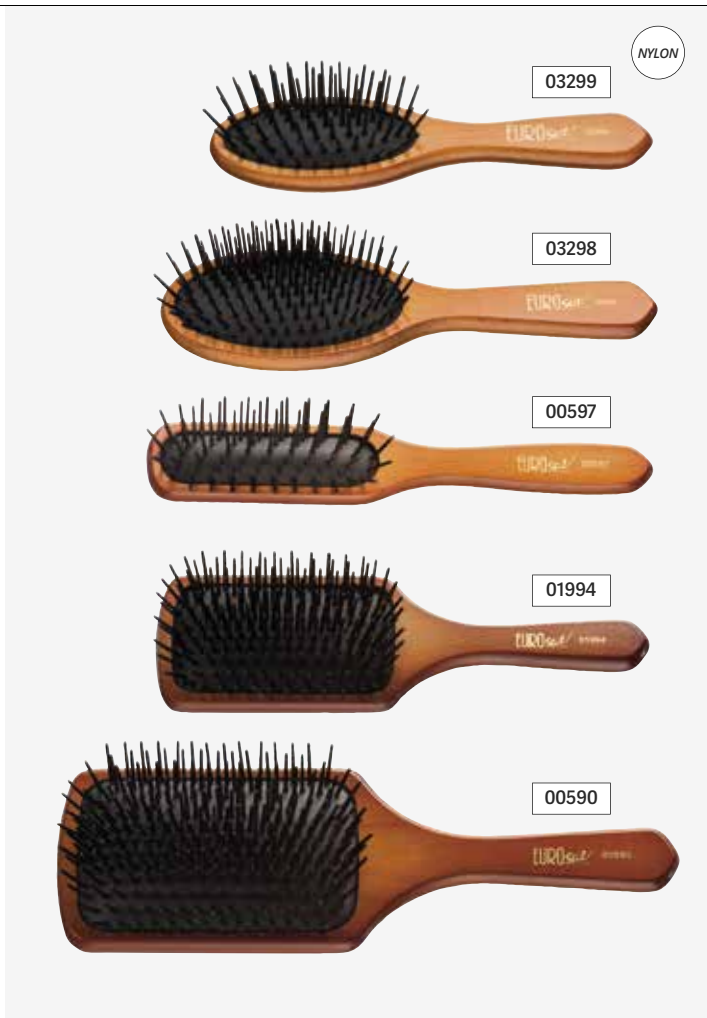

Expositor madera 20 cepillos
Display of 20 wooden brushes

u.m.vta: 1  4



REF.03387

- Cepillo cómodo
- Desenreda fácilmente
- Ergonómico y ligero
- Clásico y elegante

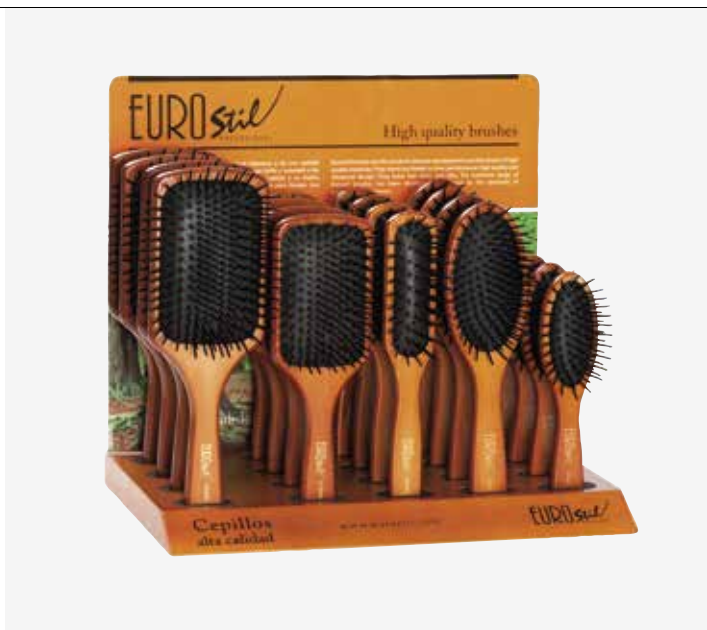
- Comfortable brush
- Detangle easily
- Lightweight and ergonomic
- Classic and elegant



Cepillos bambú
Bamboo brushes

u.m.vta: 1		6	
------------	---	---	---



REF. 07542



REF. 07543



Cepillos bambú
Bamboo brushes

u.m.vta: 1		12	
------------	---	----	---

REF. 03225



REF. 03224

REF. 03223

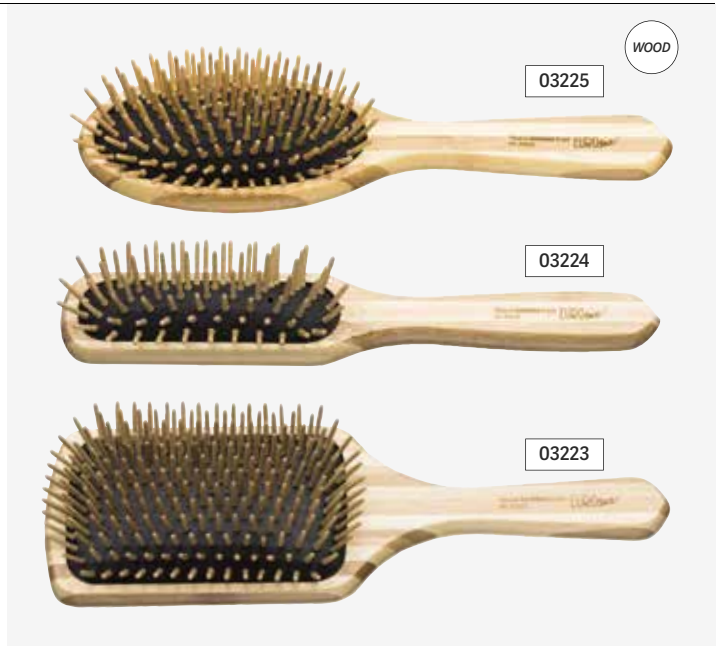



- Cuerpo cepillo y púas de madera natural de bambú
- Producción de la madera controlada
- Cepillo antiestático
- Proporcionan brillo y suavidad al cabello
- Madera muy resistente y flexible

- The body of the brush and the bristles are made from natural bamboo wood
- Controlled wood production
- Anti-static brush
- Provide hair with softness and shine
- Strong and highly flexible wood

Cepillo con fuelle y mango madera
Cushion brush with wooden handle

- Púas de madera
- Wooden bristles

u.m.vta: 1	 12	
------------	--	---

REF. 01922

REF. 01921

REF. 01920

REF. 01919





Cepillo con fuelle y mango madera
Cushion brush with wooden handle

- Púas de nylon
- Nylon bristles

Pequeño
Small

Grande
Big

u.m.vta: 1	 70
------------	--

u.m.vta: 1	 50
------------	--



REF. 01924

REF. 01923



Cepillo fuelle desenredar
Detangler cushion brush

Púa de plástico con bola
 Plastic bristle with ball

u.m.vta: 1	 12	
------------	--	---

REF. 04282

REF. 04281



REF. 04280

REF. 04279



Cepillo fuelle mango plástico
Cushion brush with plastic handle

Cerdas de jabalí y púa plástico blanca
Boar bristles and white plastic spike

u.m.vta: 1  12 

REF. 03691

REF. 03690

REF. 03693

REF. 03689



ESPECIAL
EXTENSIONES
SPECIAL
EXTENSIONS



03691

03690



03693

03689





Cepillo fuelle mango plástico
Cushion brush with plastic handle

Cerdas de jabalí y púa plástico blanca
Boar bristles and white plastic spike

u.m.vta: 6  120 

REF.01472

ESPECIAL
EXTENSIONES
SPECIAL
EXTENSIONS

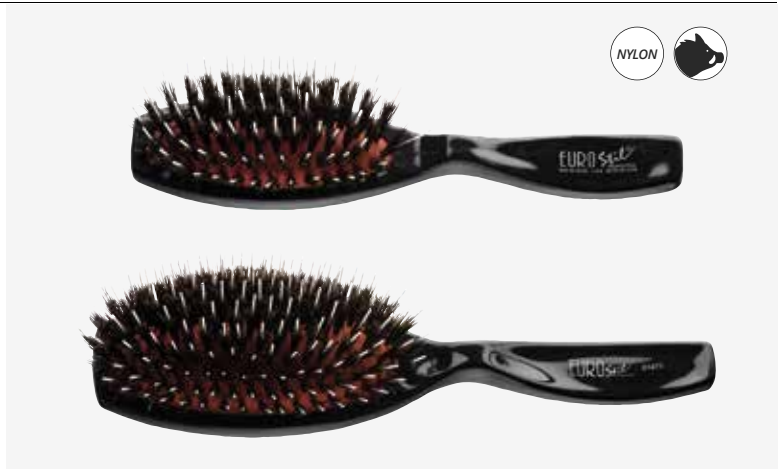

u.m.vta: 6  96 

REF.01471



Cepillo fuelle mango plástico
Cushion brush wih plastic handle



Cerdas de jabalí
 Boar bristles

u.m.vta: 1	 12	
------------	--	---

REF. 00767





Púa de plástico
 Plastic bristle

u.m.vta: 1	 12	
------------	--	---

REF. 00793



Púa de plástico con bola
 Plastic bristle with ball

u.m.vta: 1	 24	
------------	--	---



REF. 00755



- Cerdas de jabalí
- Boar bristles

Cepillo profesional ovalado
Professional oval brush

Púa de plástico con bola
 Plastic bristle with ball



u.m.vta: 1	 18	
------------	--	---

REF. 00337





Cepillo con fuelle mango de plástico
Cushion brush with plastic handle



Púa de metal con bola
Metal bristle with ball

u.m.vta: 1  36  S

   
 REF. 00158/50 REF. 00158

u.m.vta: 1  24  M

   
 REF. 00159/50 REF. 00159



u.m.vta: 1  24  L

   
 REF. 00160/50 REF. 00160



Cepillo con fuelle y mango plástico
Cushion brush with plastic handle

Púa de metal con bola
Metal bristle with ball

u.m.vta: 1  12 



REF. 00587 REF. 00586

Cepillo antiestático
Anti-static brush





Cepillo con fuelle mango plástico
Cushion brush with plastic handle



Púas de nylon
 Nylon bristles

u.m.vta: 1  36  S

   
 REF.00135/50 REF. 00135

u.m.vta: 1  24  M

   
 REF. 00144/50 REF. 00144

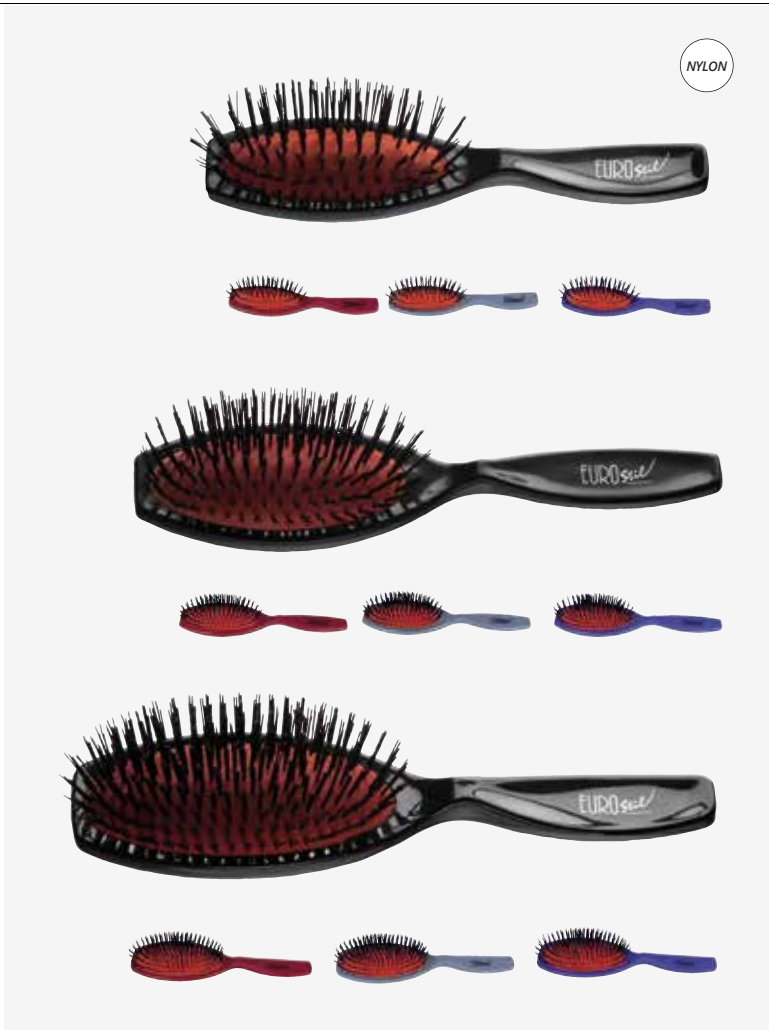

u.m.vta: 1  24  L

   
 REF. 00133/50 REF. 00133





Cepillo con fuelle mango plástico
Cushion brush with plastic handle

Púas de nylon con bola
 Nylon bristles with ball

u.m.vta: 1  26  S

   
 REF. 00555/50 REF. 00555

u.m.vta: 1  24  L

   
 REF. 00553/50 REF. 00553



Cepillo con fuelle mango plástico
Cushion brush with plastic handle

Cerdas de jabalí
Boar bristles



u.m.vta: 1 12

S

REF. 00303

u.m.vta: 1 12

M

REF. 00304

u.m.vta: 1 12

L

REF. 00305



Cepillo fuelle mango plástico
Cushion brush with plastic handle

Púas de plástico con bola
Plastic bristles with ball



u.m.vta: 1 36

REF. 00157/50

u.m.vta: 1 24

REF. 00156/50

u.m.vta: 1 24

REF. 00155/50



u.m.vta: 18 18

REF. 00309



Cepillo con fuelle mango plástico
Cushion brush with plastic handle



Púas de nylon
 Nylon bristles

u.m.vta: 1  12 

REF. 03091

REF. 03088



u.m.vta: 1  12 

REF. 03092



REF. 03089



Cerdas de jabalí
 Boar bristles

Cepillo fuelle mango plástico
Cushion brush with plastic handle

Púas de plástico con bola
 Plastic bristles with ball

u.m.vta: 1  12 

S

M

REF. 03093

REF. 03090



Cepillo fuelle mango goma
Cushion brush with rubber handle



Púas de plástico con bola
Plastic bristles with ball

u.m.vta: 1		12	
------------	---	----	---

S



REF. 03101



u.m.vta: 1		12	
------------	---	----	---

M

REF. 03098

u.m.vta: 1		6	
------------	---	---	---

L

REF. 03103

Cepillos fuelle mango goma
Cushion brush with rubber handle

Cerdas de jabalí
Boar bristles

u.m.vta: 1		12	
------------	---	----	---

S



REF. 03100



u.m.vta: 1		12	
------------	---	----	---

M

REF. 03308



u.m.vta: 1		6	
------------	---	---	---

L

REF. 03102

Cepillo con fuelle y mango de goma
Cushion brush with rubber handle

Púas de nylon
 Nylon bristles

u.m.vta: 1  12 

S

REF. 03099



M

REF. 03309



Cepillo esqueleto con mango de goma
Vent brush with rubber handle

Púas de plástico con bola
 Plastic bristles with ball

u.m.vta: 1  12 

S

REF. 03095

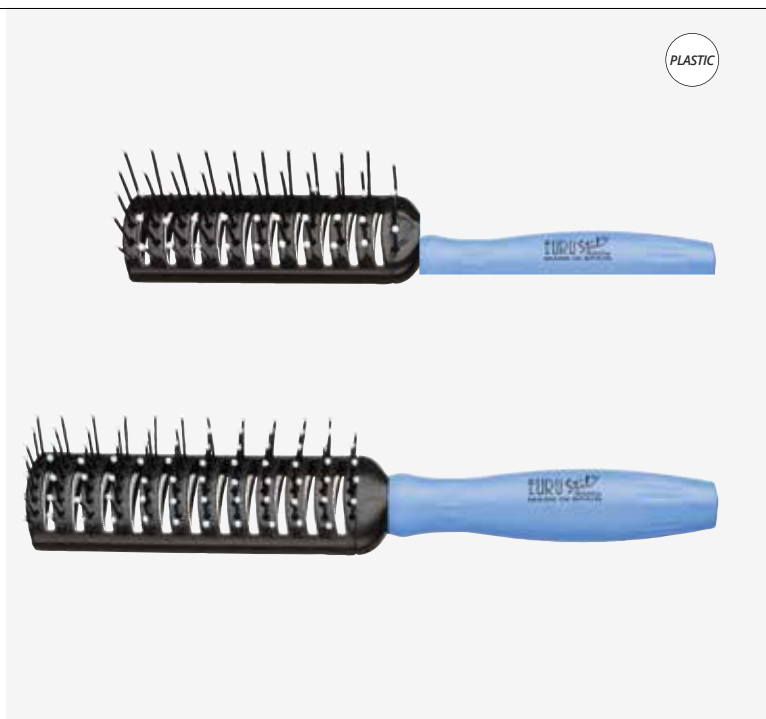

L

REF. 03094



Cepillos neumático

Pneumatic brushes

u.m.vta: 12  12 



REF.03202



Púas de plástico con bola
Plastic bristles with ball

Cepillos neumáticos que se adaptan perfectamente a la forma de la cabeza proporcionando un amplio y suave efecto de cepillado. Púas de plástico con terminación en bolita del mismo color que el cepillo. Mango cómodo y agradable al uso.

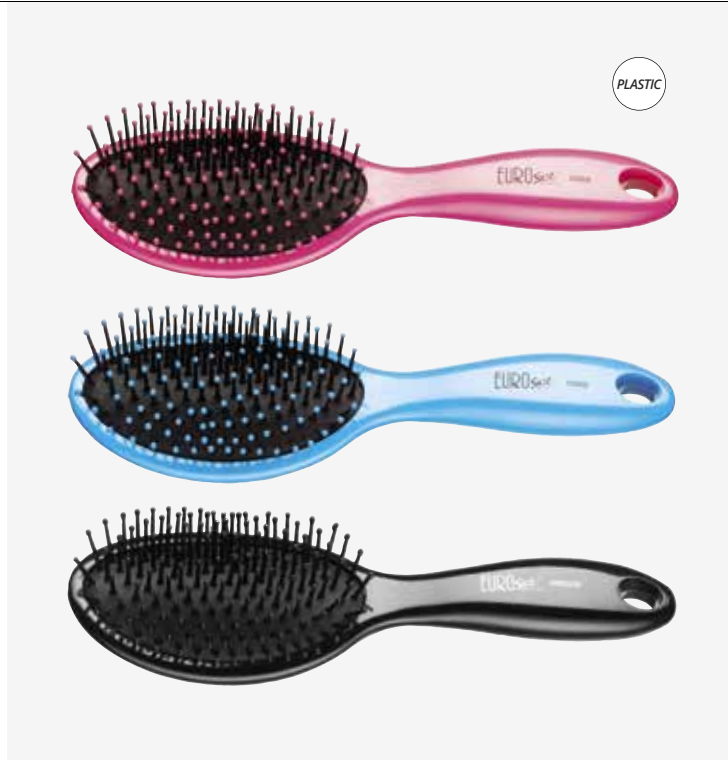
Pneumatic brushes that adapt perfectly to the shape of the scalp, providing an ample and soft brushing effect. Plastic bristles with little balls of the same colour as the brush. The handle is comfortable and pleasant to use.



Cepillo desenredar
Detangling brush

u.m.vta: 6  6 

REF. 03881





*¿Quieres saber más?
Do you want to know more?*

SCAN ME!



- 3 alturas de púas: 120 púas pequeñas, 123 púas medianas, 119 púas grandes
- Mango ergonómico
- Flexible y suave pero eficiente
- Termoplástico de 1ª calidad
- Para cabello mojado o seco
- NO rompe el cabello
- Ligero y cómodo de usar
- Con poca carga estática
- Resistente a los productos químicos
- Con curvatura para adaptarse mejor a la cabeza
- Cepillos bicolor (colores variados)

- 3 bristle lengths: 120 short bristles
- 123 medium bristles. 119 large bristles
- Ergonomic handle
- Soft and flexible yet efficient
- Top-quality thermoplastic
- For wet or dry hair
- Does NOT break the hair
- Lightweight and easy to use
- Low static charge
- Resistant to chemical products
- Curvature shape to better fit the head
- Bicolour brushes (mixing colours)

u.m.vta: 6  6 



REF. 03881/97



Expositor 120 cepillos desenredar
Display of 120 detangling brushes

u.m.vta: 1  1

Surtido colores
 Assorted colours

REF.04875

u.m.vta: 1  1

Colores Metálicos
 Metallic colours



REF.04875/97

u.m.vta: 1  1

REF.04875/01



Cepillo esférico 3D 3D spherical brush

u.m.vta: 1  12 

REF. 04968



Cepillo esférico 3D. Evita que el cabello se enrede. Se puede girar 360° para crear rizos y ondulaciones. Sus púas espaciadas permiten una mejor circulación del aire reduciendo el tiempo de secado a la mitad.

3D spherical brush. Prevents hair from getting tangled. It can be 360 degrees spinned to create curls and hair waves. With division to improve the air circulation reducing half the time the drying process.



Expositor 20 cepillos de madera
Display of 20 wooden brushes

Púas rectas de plástico
 Paddle plastic bristles

u.m.vta: 1  1

REF.03387

Incluye 4 unidades por referencia
 It includes 4 units per reference

REF. 03299
 REF. 03298
 REF. 00590
 REF. 01994
 REF. 00597



Expositor 12 cepillos rectangulares de madera
Display of 12 rectangular wooden brushes

Púas rectas de plástico
 Paddle plastic bristles

u.m.vta: 1  1

REF.01166

Incluye 12 unidades
 It includes 12 units

REF. 00590



Expositor 12 cepillos fuelle grande
Display of 12 large cushion brushes

Púas de nylon
 Nylon bristles

u.m.vta: 1  1

REF.01165

Incluye 12 unidades
 It includes 12 units

REF. 00133



Expositor 20 cepillos térmicos
Display of 20 thermal brushes

Púas de nylon
 Nylon bristles

u.m.vta: 1  1

REF.01176

Incluye 4 unidades por referencia
 It includes 4 units per reference

REF. 00579
 REF. 00580
 REF. 00581
 REF. 00582
 REF. 00780

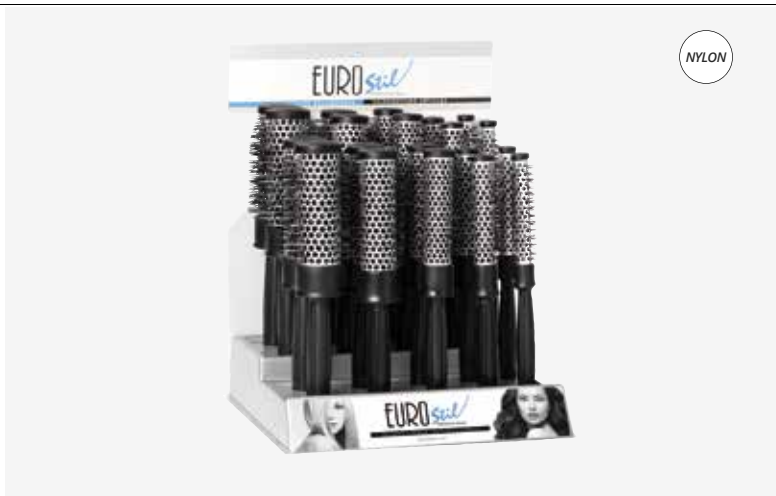

Expositor 12 cepillos esqueleto TUNEL
Display of 12 TUNNEL vent brushes

Púas de plástico con bola
 Plastic bristles with ball

u.m.vta: 1  1

REF.01167

Incluye 12 unidades
 It includes 12 units

REF. 00754



Expositor 24 cepillos térmicos
Display of 24 thermal brushes

Púas de nylon
 Nylon bristles

u.m.vta: 1  1

REF.07431



Incluye 4 unidades por referencia
 It includes 4 units per reference

REF. 00355
 REF. 00356
 REF. 00357
 REF. 00358
 REF. 00359
 REF. 00360





Cepillos esqueletos colores
Colours vent brushes



Púas de plástico con bola
 Plastic bristles with ball

u.m.vta: 32	 32	
-------------	--	---

   
 REF.00551/50 REF.00551

u.m.vta: 1	 36	
------------	--	---

REF.00768

u.m.vta: 20	 20	
-------------	--	---

   
 REF.00550/50 REF.00550

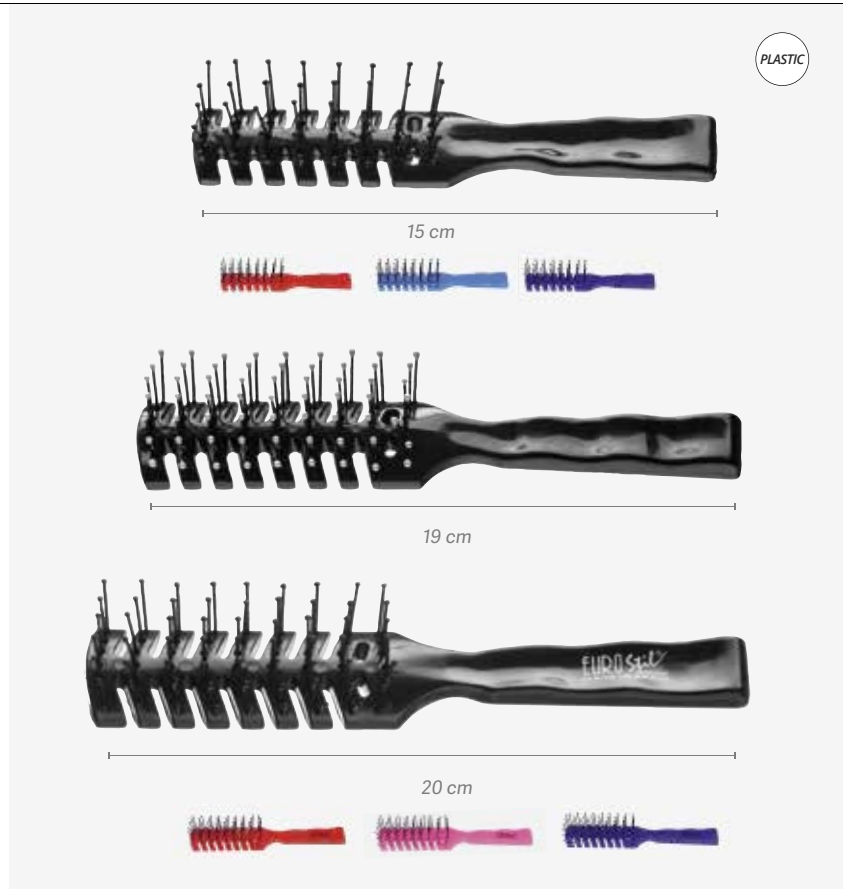

Cepillo esqueletos dos púas bola grande colores metálicos
Large vent brushes with two bristles with ball metallic colours

u.m.vta: 20	 20
-------------	--



   
 REF.00550/97

- Púas de plástico con bola. Colores surtidos
- Plastic bristles with ball. Assorted colours



Cepillos esqueletos de goma colores
Colours rubber vent brushes



Púas de plástico con bola
Plastic bristles with ball

u.m.vta: 12		12	
-------------	---	----	---

REF.00575

REF.00574



u.m.vta: 20		20	
-------------	---	----	---

REF.00576

REF.00754

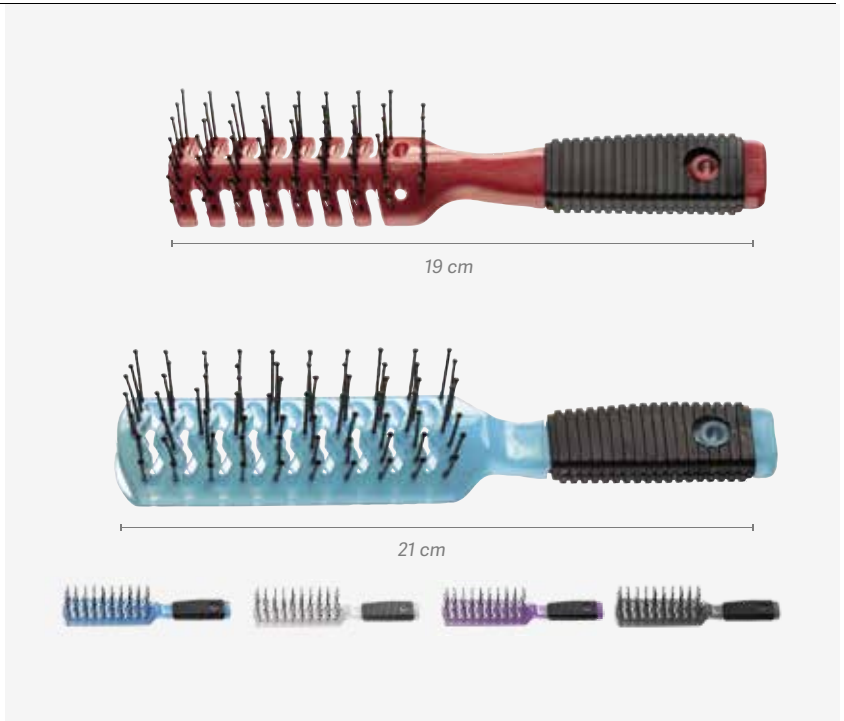

Cepillos esqueleto
Vent brushes

Púas de plástico con bola
Plastic bristles with ball

u.m.vta: 12  12

S

REF.03087

L

REF.03086

u.m.vta: 1  16

 REF. 02203/50   REF. 02203

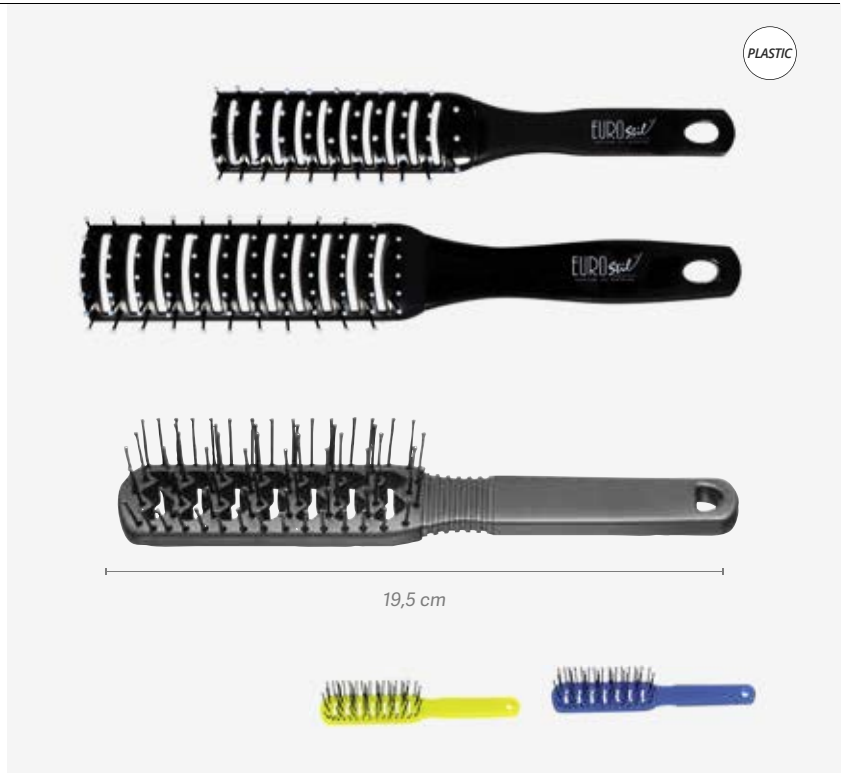



PLASTIC

19,5 cm

Cepillos esqueleto ANTIESTÁTICOS
ANTIESTATIC vent brushes

Púas de plástico con bola
Plastic bristles with ball

u.m.vta: 1  12 

S

REF.00585

L

REF.00584

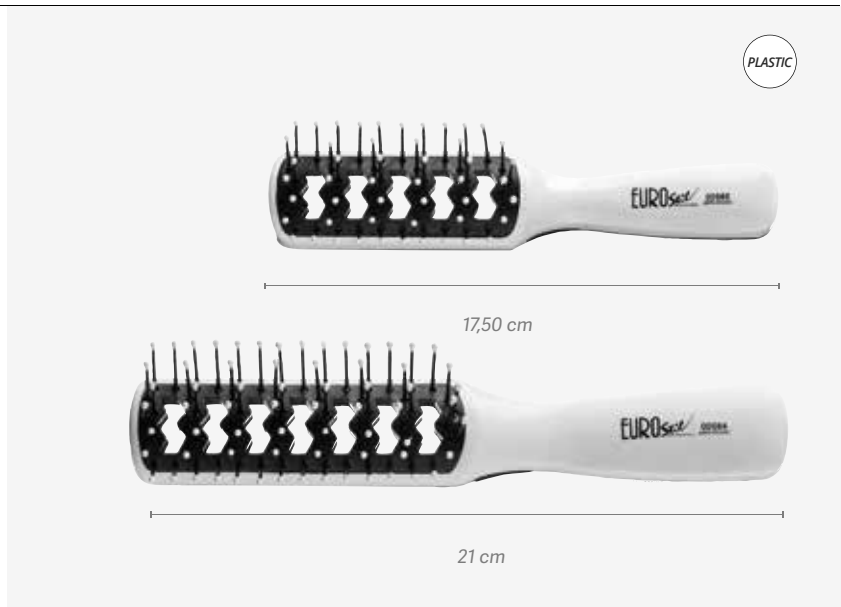

PLASTIC

17,50 cm

21 cm

Cepillos esqueleto colores
Colours vent brushes

Púas de plástico
Plastic bristles

u.m.vta: 12  12

     
REF.00534/50 REF.00534

u.m.vta: 20  20

     
REF.00533/50 REF.00533



u.m.vta: 20  20

     
REF.00535/50 REF.00535



Cepillos flexibles esqueleto
Flexible vent brushes

Púas de metal
Metal bristles

u.m.vta: 1  12 



S **L**
REF. 04405 REF. 04406



Cepillos curvos esqueleto de colores

Curved colours vent brushes

Púas de plástico con bola
Plastic bristles with ball

u.m.vta: 1  12 

REF.03201

REF. 02195/50

  
REF. 02195





Cepillos curvos para una mejor adaptación a la forma de la cabeza, ligeros y cómodos de utilizar por su diseño ergonómico. Once filas de púas en forma anatómica en plástico, con terminación en bolita del mismo color que el cepillo.

Curved brushes for a better adaptation to the shape of the head, light and comfortable to use for its ergonomic design. 11 rows of bristles in anatomical shape, in plastic with a ball termination of the same color as the brush.

Cepillos esqueleto dobles

Double vent brushes

Púas de plástico con bola. Colores variados
Plastic bristles with ball. Mix colours

u.m.vta: 24  24 

REF. 02182/50

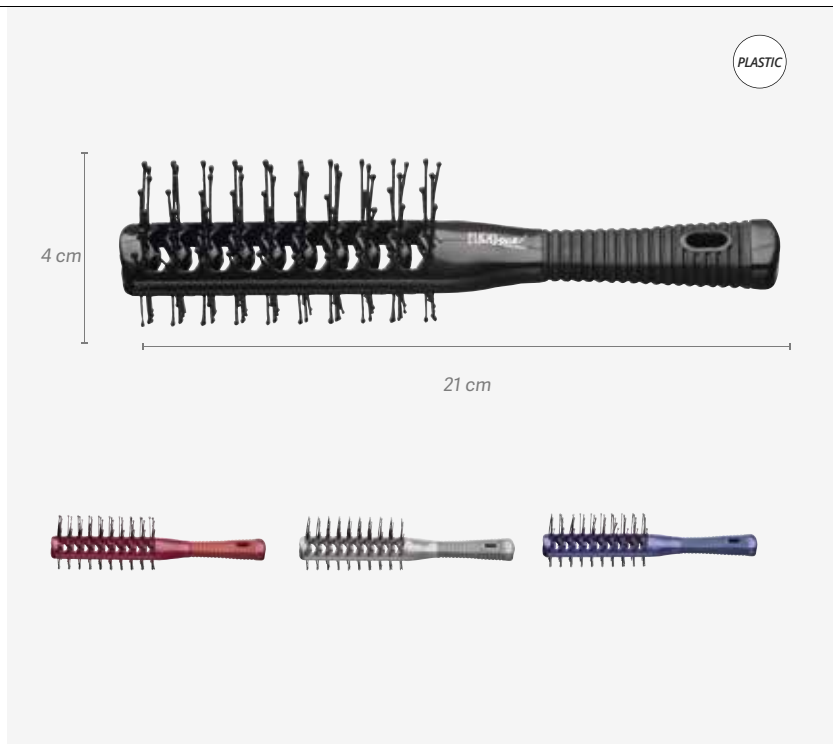

u.m.vta: 24  24

  
REF. 02182



Cepillo desenredar mango plástico
Detangling brush with plastic handle

Púa doble altura con doble bola
 Double height bristle with double ball

u.m.vta: 1  12 

S

L

REF.06609

REF.06610

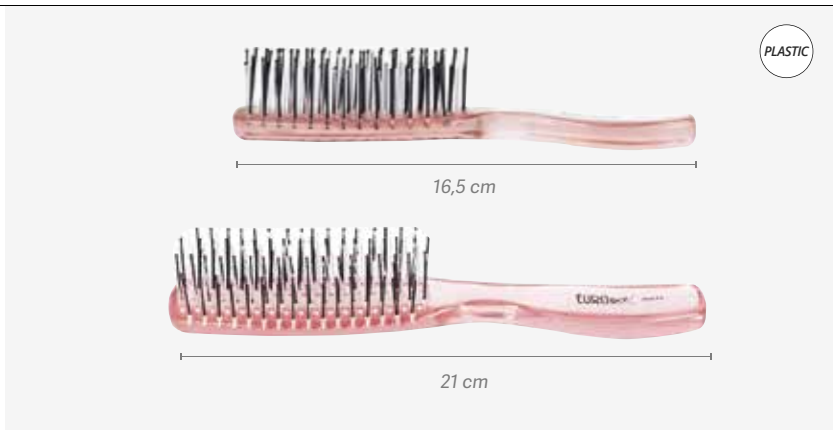

Línea de cepillos desarrollada especialmente para cabellos quebrados

Brushes line specially developed for broken hair

Cepillo plano plástico
Plastic flat brush

Púas de plástico con bola
 Plastic bristles with ball

u.m.vta: 12  12

S



L



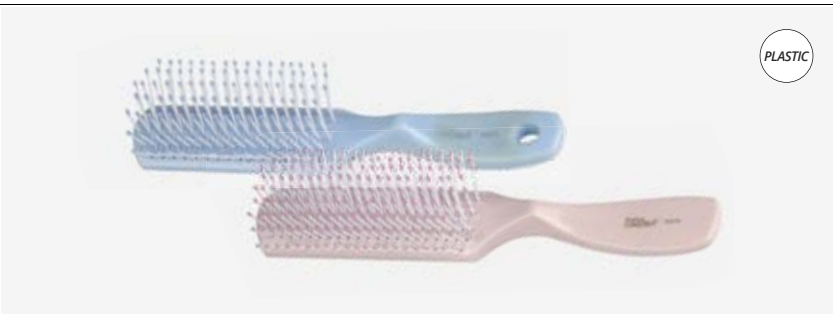

REF.00571

REF.00570



Cepillo plano goma
Flat rubber brush

Púas de plástico
 Plastic bristles

u.m.vta: 1  12 

REF. 04700



Cepillo espejo plegable
Folding mirror brush

Púas de plástico con bola
 Plastic bristles with ball

u.m.vta: 24  24



REF.00329



REF.00329/50

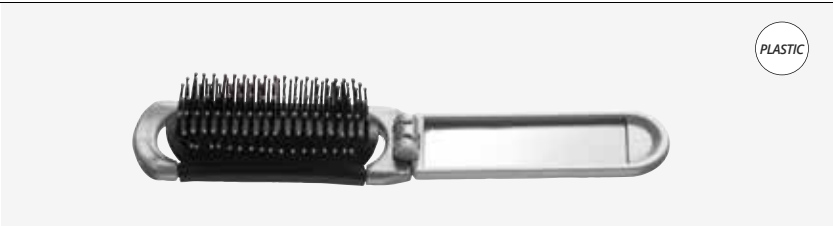

Cepillo plástico

Plastic brush

Púas de plástico
Plastic bristles

u.m.vta: 24  24

  
REF.01850/50 REF.01850



Cepillo rizador

Curling brush

Púas de plástico
Plastic bristles

u.m.vta: 20  20 

REF.00386



Peine profesional para alisado con plancha

Professional comb for hair straightener



u.m.vta: 1  12 

REF. 03262



Doble cepillo térmico para alisar. Uso con secador

Double thermal brush for smoothing. For hair dryer

u.m.vta: 1  12 

 REF. 02365

 REF. 01957

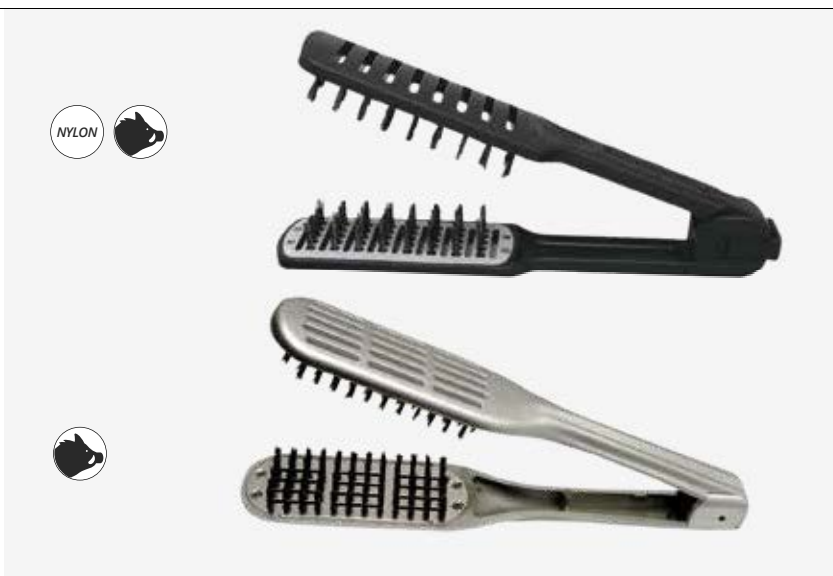

Peines lendreras de polipropileno
Propylen nit combs

Púas de plástico
Plastic bristles

u.m.vta: 12	120	
-------------	-----	--



REF. 00443



REF. 00443/50



Peines lendreras
Nit combs

Púas de metal
Metal bristles

u.m.vta: 12	12
-------------	----

REF.03305



Cepillo y peine bebé
Brush & comb for baby

Púas de metal
Metal bristles

u.m.vta: 5	15
------------	----



REF.00670





REF.00670/75



REF.00670/70



Peine con niveles Comb with levels



u.m.vta: 1  120 

REF. 04349



Gracias a sus tres niveles, permite la realización del corte o escalado en una línea recta perfecta
This comb with levels allows you to make a layered cut or to cut hair in a perfect straight line thanks to its 3 levels

Cepillo limpia-peines Cleaning combs

u.m.vta: 1  100 

REF. 00600





Set cepillo y peine plateados Set silver brush and comb

u.m.vta: 1  12

REF. 03488



Línea de cepillos Ionic
Ionic brush line

u.m.vta: 1	 6	
------------	---	---

NEW

Ø 20

REF. 07536



Ø 25

REF. 07525



Ø 35

REF. 07524



Ø 45

REF. 07523



Ø 55

REF. 07522



REF. 07526



REF. 07527





Ref. 07522, 07523, 07524, 07525

Mango ergonómico de goma antideslizante para un buen agarre y adaptación a la mano. Punta de separación retráctil insertada en el final del mango de los cepillos ideal para realizar secciones en el cabello. El cepillo térmico iónico proporciona un peinado suave y una protección antibacteriana que da brillo y fuerza al pelo, gracias a las cerdas de nylon antiestáticas y cargadas de iones, reducen la carga estática. Brillo sublime.

Ergonomic non-slip rubber handle for a good grip and adaptation to the hand. Retractable separating tip inserted at the end of the brush handle, ideal for sectioning hair. The ionic thermal brush provides smooth styling and antibacterial protection that gives shine and strength to the hair, thanks to the antistatic and ion-charged nylon bristles that reduce static charge. Sublime shine

Cepillos térmicos cerámicos-iónicos con mango de goma

Ceramic-ionic thermal brush with rubber handle

u.m.vta: 1	 24	
------------	--	---

Ø 20

REF. 02312

Ø 20





Ø 25

REF. 02313

Ø 25



u.m.vta: 1	 20	
------------	--	---

Ø 33

REF. 02314

Ø 33





Ø 43

REF. 02315

Ø 43



u.m.vta: 1	 20	
------------	--	---

Ø 53

REF. 02316

Ø 53



26 cm

- Con recubrimiento cerámico para dar el cabello más brillo y protección. E iónico que evita encrespamiento
- Con mango de goma con acabado antideslizante
- Púas de nylon
- Púa extraíble
- Con colgador

- With ceramic coating to give the hair more shine and protection. And ionic that prevents frizz
- With rubber handle with non-slip finish
- Nylon bristles
- Removable bristle
- With hanger



Cepillos térmicos con mango redondo de plástico
Thermal brushes with round plastic handle

Púas de nylon. Con colgador
 Nylon bristles. With hanger

u.m.vta: 1		40	
------------	---	----	---

Ø 9

REF. 00578

u.m.vta: 1		30	
------------	---	----	---



Ø 13

REF. 00579

u.m.vta: 1		24	
------------	---	----	---

Ø 18

REF. 00580

u.m.vta: 1		24	
------------	---	----	---



Ø 24

REF. 00581

u.m.vta: 1		20	
------------	---	----	---



Ø 30

REF. 00582

u.m.vta: 1		30	
------------	---	----	---

Ø 36

REF. 00780

u.m.vta: 1		20	
------------	---	----	---

Ø 42

REF. 00779

NYLON

Ø 9



Ø 13



Ø 18



Ø 24



Ø 30



Ø 36



Ø 42







24,5 cm

Tubo cerrado
 aluminio
 Aluminium
 close tube

Cepillos térmicos con mango de plástico y tubo plano abierto de aluminio
Thermal brushes with plastic flat handle and aluminum open tube



Púas de nylon. Con colgador
 Nylon bristles. With hanger



u.m.vta: 1		30	
------------	---	----	---

u.m.vta: 1		24	
------------	---	----	---

Ø 13
REF. 00355



Ø 18
REF. 00356



u.m.vta: 1		24	
------------	---	----	---

u.m.vta: 1		20	
------------	---	----	---

Ø 24
REF. 00357



Ø 30
REF. 00358



u.m.vta: 1		30	
------------	---	----	---

u.m.vta: 1		20	
------------	---	----	---

Ø 36
REF. 00359

Ø 42
REF. 00360

u.m.vta: 1		16	
------------	---	----	---

u.m.vta: 1		12	
------------	---	----	---

Ø 50
REF. 02661

Ø 61
REF. 02662

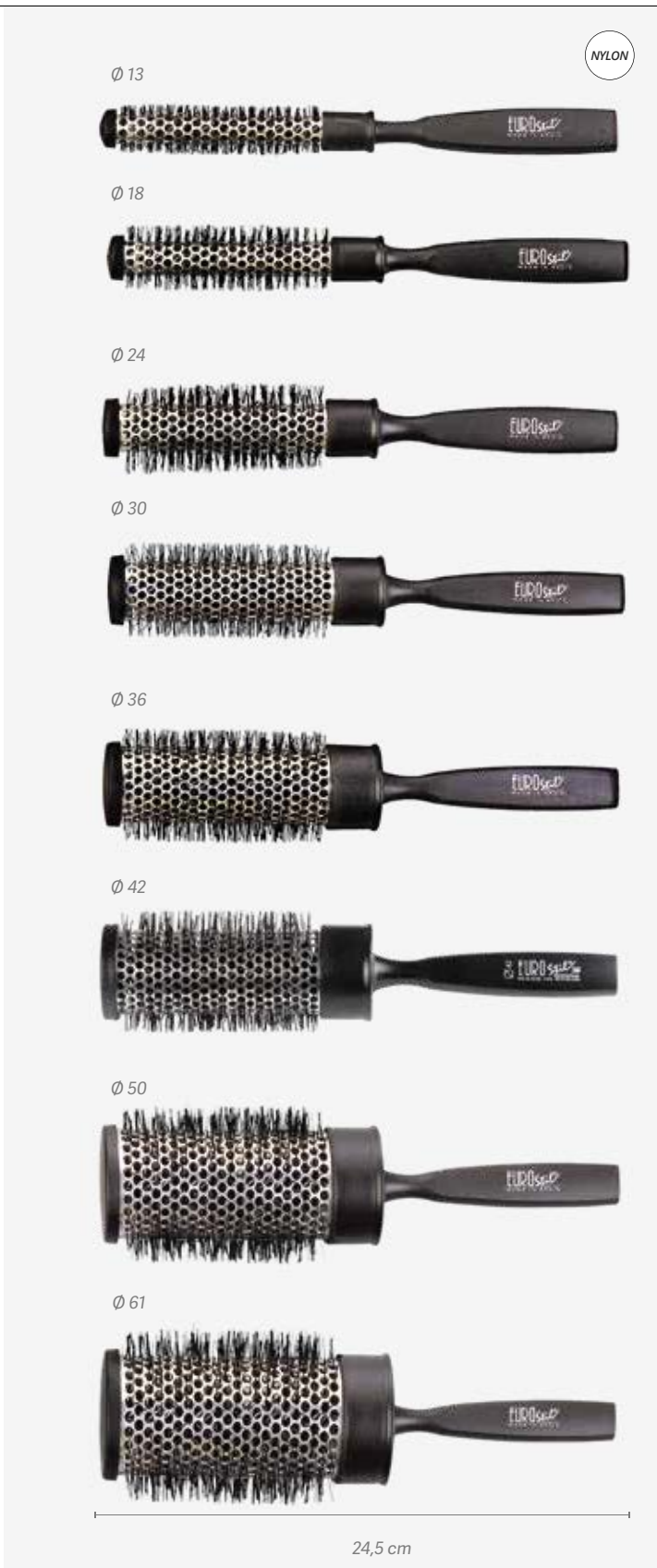

Cepillos térmicos de aluminio con el mango en goma de nylon
Aluminium thermal brushes with nylon rubber handle

Púas de nylon. Con colgador
 Nylon bristles. With hanger

u.m.vta: 1	 12	
------------	--	---

Ø 18

REF. 03346

Ø 24

REF. 03347

Ø 30

REF. 03348

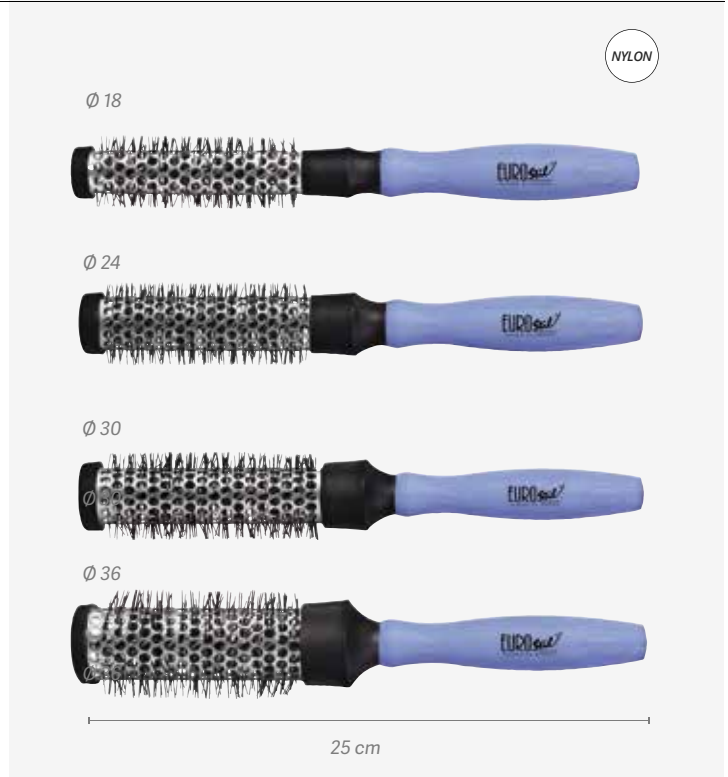

Ø 36

REF. 03349



Cepillos térmicos cerámicos con mango de madera
Ceramic thermal brushes with wooden handle

Púas de nylon. Con colgador
 Nylon bristles. With hanger

u.m.vta: 1	 12	
------------	--	---

Ø 25

REF. 03457

Ø 33

REF. 03458



Los cepillos térmicos de cerámica de última generación tienen un cuerpo central de aluminio, recubierto de cerámica para asegurar una alta resistencia y una distribución uniforme del calor a lo largo del cuerpo del cepillo.

Our cutting-edge thermal ceramic brushes have a central aluminum core clad in ceramics in order to ensure a high level of heat resistance and a uniform spread of heat throughout the body of the brush.

Cepillo térmico con mango de madera
Thermal brush with wooden handle

Púas de nylon + jabalí. El cuerpo del cepillo es metálico y de madera
 Nylon bristles + boar. The body of the brush is metallic and wooden

u.m.vta: 1  6 

Ø 15

REF. 06583



Ø 25

REF. 06582



Ø 34

REF. 06581



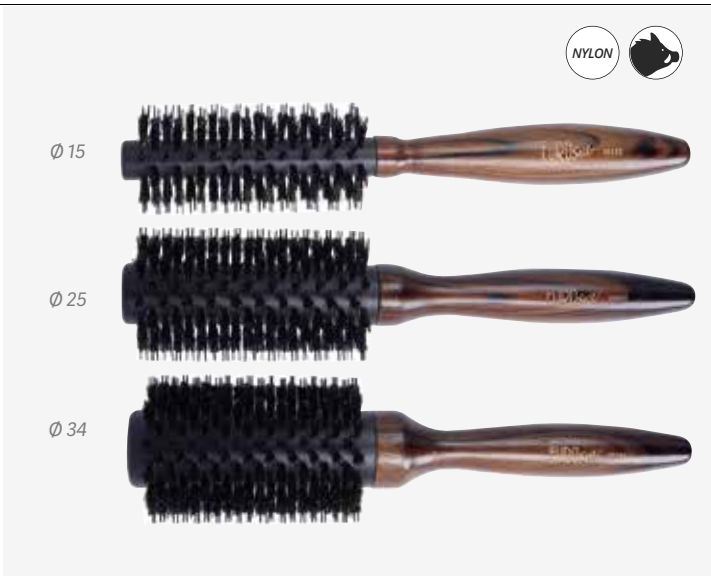

- Cerdas de jabalí y nylon a 2 niveles para mejorar la sujeción del cabello. Línea de cepillos desarrollada en España para cabellos densos y con volumen
- 2-level wild boar and nylon bristles to improve hair support. Line of brushes developed in Spain for thick and bulky hair



Cepillo circular mando goma térmico
Circular rubber thermal brush

Púas de nylon + jabalí. El cuerpo del cepillo es metálico y de madera
 Nylon bristles + boar. The body of the brush is metallic and wooden

u.m.vta: 1  6 

Ø 15

REF. 06685



Ø 25

REF. 06684



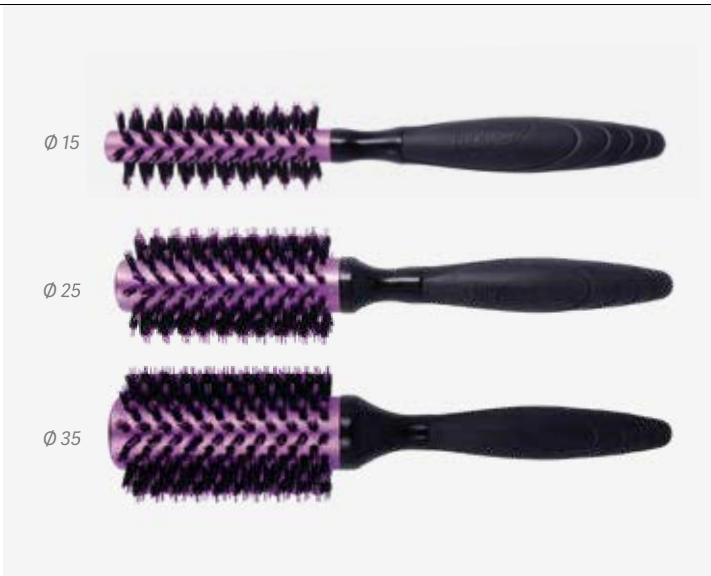

Ø 34

REF. 06683



Peines batidor profesional
Professional cutting combs

u.m.vta: 12  72 



REF. 04616

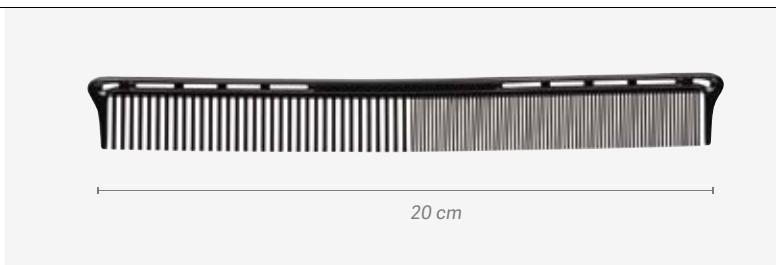



   
REF. 04616/98

    
REF. 04616/97

    
REF. 04616/99





Peine batidor púa especial
Special pin cutting comb

u.m.vta: 12  72 





REF. 00441

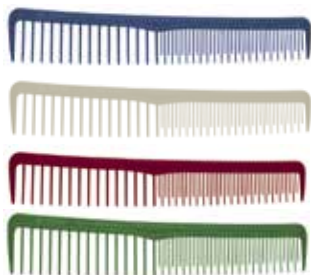

u.m.vta: 12  72 

   
REF. 00441/98





u.m.vta: 12  32 

    
REF. 00441/99



Peine batidor púa especial
Special pin cutting comb

u.m.vta: 12  72 

REF. 00442

Reforzado
Strengthened



REF. 00424

Súper largo
Extralong

REF. 01470



Peine batidor grande
Large cutting comb

u.m.vta: 12  72 



REF. 00115





REF. 00115/97

REF. 00115/98

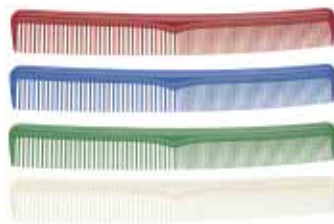
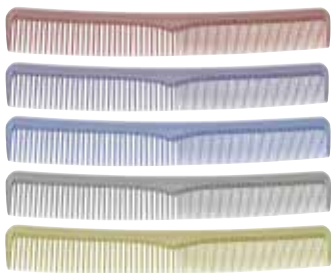
REF. 00115/99



Peine batidor púa especial
Special pin cutting comb

u.m.vta: 12  72 



REF. 00116



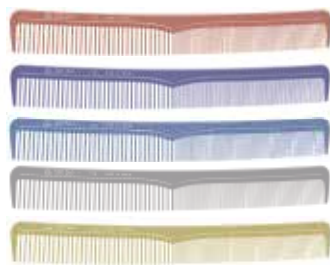

REF. 00116/97

REF. 00116/98

REF. 00116/99



Peine especial peluquero
Special hairdresser comb

u.m.vta: 12  72 



REF. 00422

REF. 00422/58



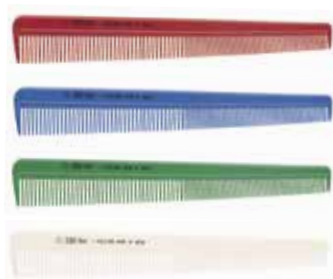

REF. 00422/98

REF. 00422/99



Peine púas especial
Special pins comb

u.m.vta: 12  72 



REF. 00423



REF. 00423/97

REF. 00423/98

REF. 00423/99



Peine púa nylon
Nylon pin tail comb

u.m.vta: 12  72 





REF. 00114



REF. 00114/99



Peine púa metal nylon
Iron nylon pin tail comb

u.m.vta: 12  72 





REF. 00118



REF. 00118/99



Peine púa metal
Metal pin tail comb

u.m.vta: 12  72 



REF. 01467



REF. 01468



Peine ahuecador 5 púas metal
5 iron pins styling comb

u.m.vta: 12  72 



REF. 00128



 REF. 00128/98



 REF. 00128/99





u.m.vta: 12  72 

Peine corte especial máquina
 profesional trimmer
*Special cutting comb for trimmer
 prof. machine*

REF. 02472





u.m.vta: 18  54 

Peine profesional batidor
Professional cutting comb

REF. 02304



Peine batidor mechas
Streak cutting comb

u.m.vta: 12  48 

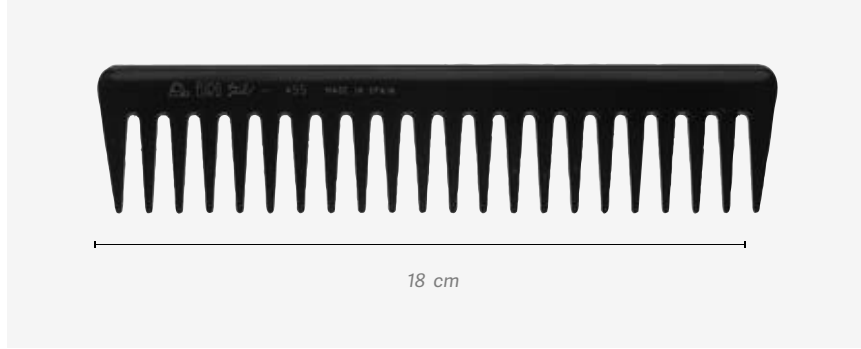

REF. 00455



REF. 00455/99



Peine batidor recto
Straight cutting comb

u.m.vta: 12  48 



REF. 00454



REF. 00454/99



Peines profesionales EUROSTIL
EUROSTIL professional comb

u.m.vta: 12  36 





REF. 00452

Peine batidor plástico
 doble púa
*Plastic double pin cutting
 comb*



Peines Eurostil corte especial máquina profesional
Special cutting comb professional machine

u.m.vta: 12  60 

MOD. 06802

REF.06802

MOD. 06802/82

REF.06802/82





u.m.vta: 12  60



REF.02183



Peine escarpidor grande
Large styling comb

u.m.vta: 12  48 



●
REF. 00453



REF. 00453/99



Peine batidor negro
Black cutting comb

u.m.vta: 12  48 

●
REF. 00136/50





REF. 00136

REF. 00136/97

REF. 00136/98



Dispensador 100 peines un uso precintados
Dispenser of 100 disposable sealed combs

u.m.vta: 1  3

REF.03053



SCAN ME!



Peine precintado para asegurar la garantía de la no utilización en anteriores servicios.
 Sealed comb to ensure the guarantee of non-use in previous services.

Colores clásicos
 Classic colours

REF.03053/98



Colores metalizados
 Metallic colours

REF.03053/97





Colores verano
 Summer colours

REF.03053/99



Peines profesionales Professional combs



u.m.vta: 12  60 

REF. 00177/50





REF. 00178/50



u.m.vta: 12  120 



REF. 00179/50



u.m.vta: 12  72 

REF. 00113



u.m.vta: 12  120 

REF. 00180/50





Los peines profesionales ahora en divertidos colores para hacer más atractivo y alegre tu salón. Las referencias terminadas en /99 son las de peines de colores: verde, azul, naranja, rosa, fucsia y lila. En la fotografía se puede apreciar la gama cromática.

Our professional combs are now available in attractive colours to make your salon even more colourful. Product references ending in /99 are for coloured combs: available in green, blue, orange, pink, fuchsia and purple. The range of colours can be seen on the photograph.



Peines CARBONO

CARBON combs

u.m.vta: 12	 72	
-------------	--	---



REF. 02186

Batidor corte
Cutting comb

**REF. 02216**

Batidor corte
Cutting comb





u.m.vta: 12	 96	
-------------	--	---

REF. 02214

Batidor púa especial
Special pin comb



u.m.vta: 12	 72	
-------------	---	--



REF. 02215

Especial peluquero
Special hairdresser

**REF. 02187**

Púa especial
Special pin



u.m.vta: 12	 48	
-------------	--	---



REF. 02188

Batidor mod. Recto
Straight mod. cutting comb



Peines CARBONO

CARBON combs

u.m.vta: 12  240 

REF. 03408 Peine batidor púa separación
Cutting comb
separate pin





19,1 cm

REF. 03407 Peine batidor púa separación
Cutting comb
pin separate





21,7 cm

u.m.vta: 12  192 

REF. 03406 Peine púa separación
Cutting comb
pin separate



21,5 cm

u.m.vta: 12  240 

REF. 03411 Peine púa metal profesional
Professional metal
pin comb



22,3 cm

REF. 03410 Peine púa profesional
Professional pin
comb



21,5 cm

Peines anónimos gran consumo
No brand combs mass consumption

u.m.vta: 120  120

Peine batidor
 Cutting comb

REF.00458



17,5 cm

Peine púa, plástico
 Tail comb, plastic

REF.00459



20,5 cm

Peine 5 púas metálicas
 5 iron pins comb

REF.00461



19,5 cm

Peine púa metálicas
 Tail comb, iron

REF.00460



21,5 cm

Set 9 peines profesionales peluquero, nylon
Set 9 professional hairdresser combs nylon

u.m.vta: 6  6

REF.03928/99

Incluye 9 peines
 profesionales de colores
*It includes 9 professional
 colours combs*

REF. 00453
 REF. 00454
 REF. 01469
 REF. 00423
 REF. 00441
 REF. 00115
 REF. 00116
 REF. 00118
 REF. 00422





Estuche peines profesionales Set professional combs

u.m.vta: 10  10

Incluye 6 peines profesionales
It includes 6 professional combs

REF.00950

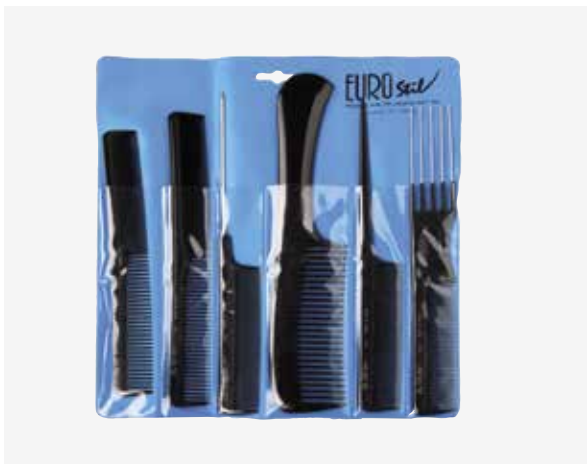
REF. 00114
REF. 00115
REF. 00116
REF. 00118
REF. 00128
REF. 00136/50

u.m.vta: 10  10

Incluye 4 peines profesionales y un cepillo esqueleto
It includes 4 professional combs & 1 vent brush

REF.00951

REF. 00114
REF. 00115
REF. 00136/50
REF. 00404/50
REF. 00550/50

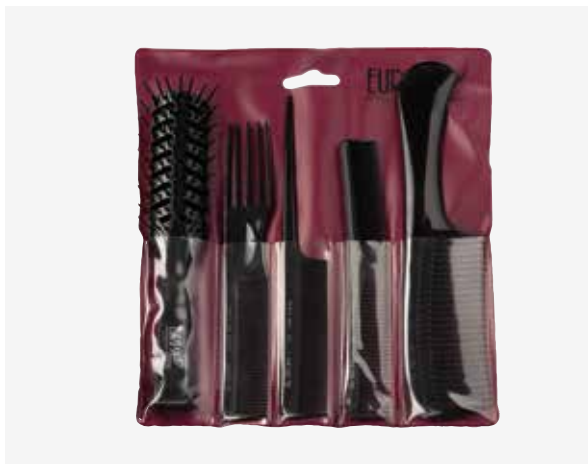

Set profesional peluquero, nylon Professional hairdresser set, nylon

u.m.vta: 6  6

Incluye 9 peines profesionales
It includes 9 professional combs

REF.03928

REF. 00423
REF. 00115
REF. 00116
REF. 00441
REF. 00453
REF. 00454
REF. 00118
REF. 01469
REF. 00422



Set utillaje profesional peluquero Professional hairdresser tool set

u.m.vta: 6  6

Incluye 9 herramientas profesionales
It includes 9 professional tools



REF.04347

REF. 00114
REF. 00115
REF. 00116
REF. 00180/50
REF. 00404/50
REF. 00136/50
REF. 00118
REF. 01977
REF. 00962/50



Peine batidor PEGASUS
PEGASUS comb



u.m.vta: 1  10 

- Peines de plástico
- Hechos a mano
- Antiestáticos

- Plastic combs
- Hand made
- Antistatic

REF. 04242

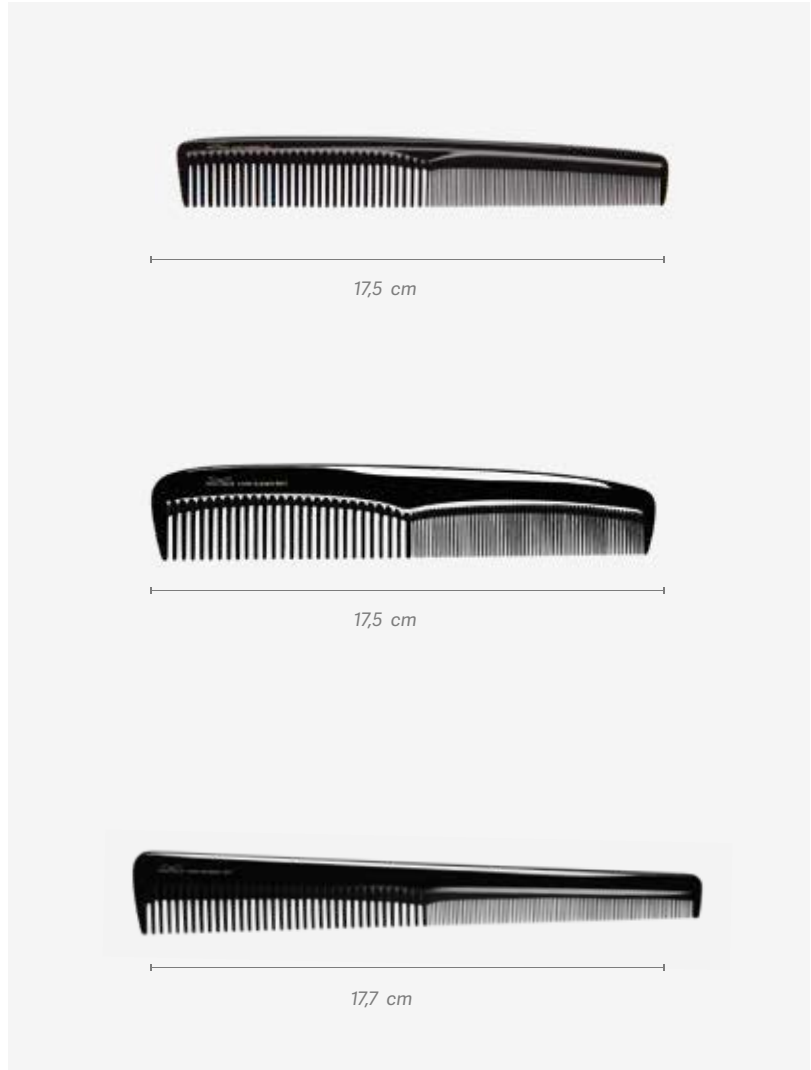

REF. 04245

Peine corte
Cutting comb

REF. 04249

u.m.vta: 1  10

Púa especial
Special pin

REF. 04246



Caja de 12 unidades de peines ahuecadores
Box 12 units of styling combs

u.m.vta: 1 40

Pollié 334

REF.01886 5 púas
5 pins



19 cm

Pollié 351

REF.01887 5 púas
5 pins



19 cm

Pollié 309

REF.01885 5 púas metálicas
5 metal pins



19,5 cm

Caja 12 unidades de peines con púa
Box 12 units of tail combs

u.m.vta: 1 40

Pollié 307

REF.01884



20,5 cm

u.m.vta: 1 50

Pollié 308

REF.01883



20,5 cm

u.m.vta: 1 40

Pollié 310

REF.01882 Púa metálica
Iron pin



21,5 cm

Caja de 12 unidades de peines batidores
Box 12 units of cutting combs



u.m.vta: 1 40

Pollié 310

REF.01876 Nylon
Nylon



Pollié 338

REF.01877 Nylon
Nylon



Pollié 339

REF.01878 Nylon
Nylon



u.m.vta: 1 50

Pollié 306

REF.01879 Especial
Special



u.m.vta: 1 40

Pollié 302

REF.01880 Especial
Special



u.m.vta: 1 50

Pollié 305

REF.01881 Nylon
Nylon



Pollié 304

REF.01875 Nylon
Nylon



Peines MATADOR
MATADOR combs

MATADOR
 PROFESSIONAL

u.m.vta: 1  12 

2255/7

REF. 02255

Batidor ancho 8,5
 Wide beater 8.5



2246/7,5

REF. 01637

Batidor ancho 7,5
 Wide beater 7.5



2246/8,5

REF. 02246



2206/9

REF. 02206

Ancho
 Width

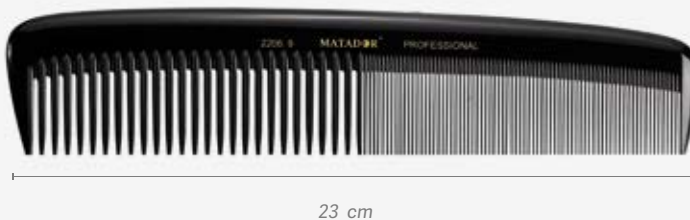

2607/9G

REF. 01638

Con mango P.A
 With handle P.A



2607/9



REF. 02607

Con mango
 With handle



Peines MATADOR

MATADOR combs

u.m.vta: 1  12 

2614/7T

REF. 01639 Púa especial
Special pin



17,5 cm

2614/7

REF. 02614 Batidor
Cutting



17,5 cm

2605/7

REF. 02330 Corte
Cutting



18 cm

2211/7

REF. 02211 • Con mango P.A
• With handle P.A



18 cm

2677/7

REF. 02331

Corte
Cut



18 cm

2660/7,25

REF. 02660

Batidor
Whisk



18,5 cm

2689/6,5

REF. 02689

Ancho
Wide



23 cm

Peines MATADOR
MATADOR combs



u.m.vta: 1 12

385/8,5G

REF. 01649



20,5 cm

391/8G

REF. 01654

Púa 8,5P
 Pin 8,5



21 cm

391/8FT

REF. 01653

Púa especial 8
 Special pin 8"



21,5 cm

386/8,5G

REF. 01652

Púa metálica
 Metal pin



21,5 cm



¿Quiere saber algo más sobre la los orígenes de la marca MATADOR?
 Want to learn more about the origins of MATADOR brand?

SCAN ME!

Peines profesionales Silkomb
Silkomb professional combs

SILKOMB™

u.m.vta: 1

50



PRO-10

REF. 01520



24 cm

PRO-11

REF. 01521



17,5 cm

PRO-20

REF. 01522



19 cm

PRO-30

REF. 01523



19 cm

PRO-40

REF. 01524

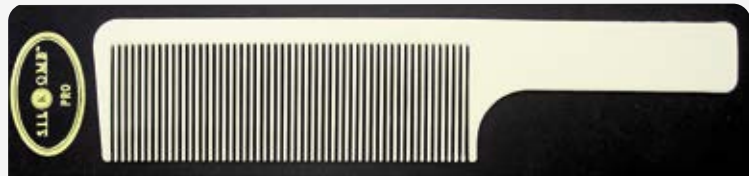

23 cm



PRO-50

REF. 01525



22,5 cm

Peine escarpidor colores
Da-tangler comb colours

u.m.vta: 12  60 



S

REF. 00400



16 cm



u.m.vta: 12  48 

M

REF. 00138



19 cm



S

REF. 00408

Púa curvada
Curved pin



17,5 cm



L

REF. 00412

Púa ancha
Wide pin



22 cm



L



REF. 00448



20,5 cm



Peine escarpidor
Da-tangler comb

u.m.vta: 12  48 

Peine escarpidor púa curvada, grande
Da-tangler curved pin comb, large

REF. 00407



u.m.vta: 36  36

Peine escarpidor mango goma
Da-tangler comb, rubber handle

REF.00425

Peine batidor recto
Straight cutting comb

u.m.vta: 12  300



S

S

REF.00111/50

REF.00111





u.m.vta: 12  48 

L

REF. 00444





Peine batidor
Cutting comb

u.m.vta: 12	 48	
-------------	--	---

Púa doble
Double pin

REF. 00435



u.m.vta: 12	 60	
-------------	--	---

Mechas colores
Streak colours

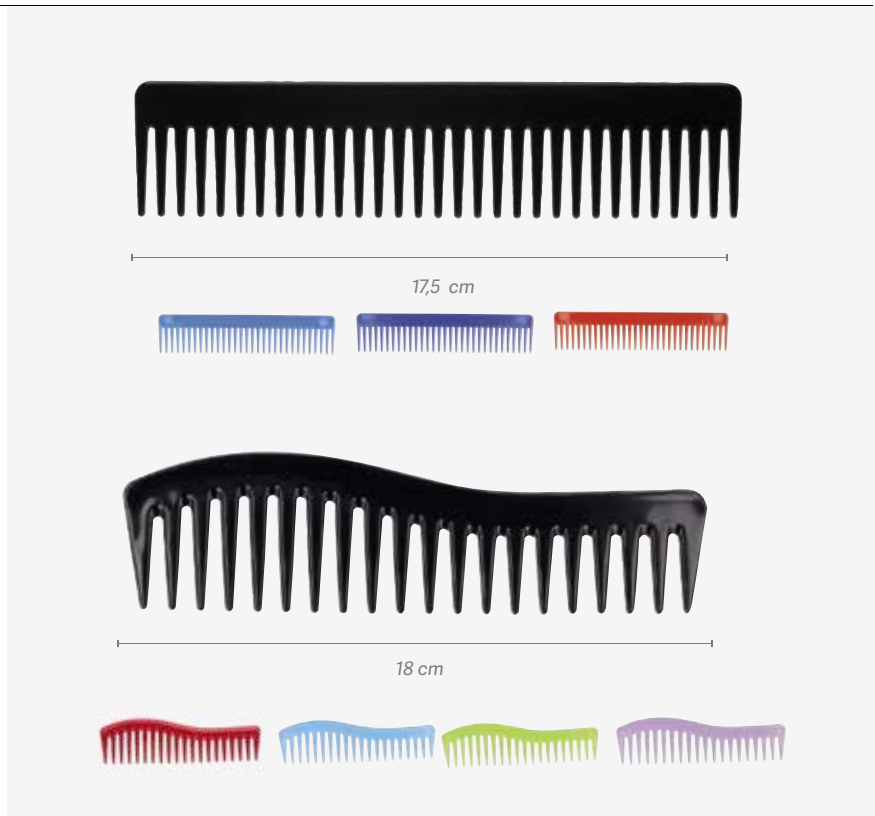

REF. 00427



u.m.vta: 12	 60
-------------	--

Mechas
Streak

REF. 00471



u.m.vta: 12	 60	
-------------	--	---

Cabello ondulado
Wavy hair

REF. 00420



Peine ahuecador colores
Da-tangler colours comb

u.m.vta: 12  60 

S

REF. 00419



REF. 00419/56 Transparente
 Transparent

L

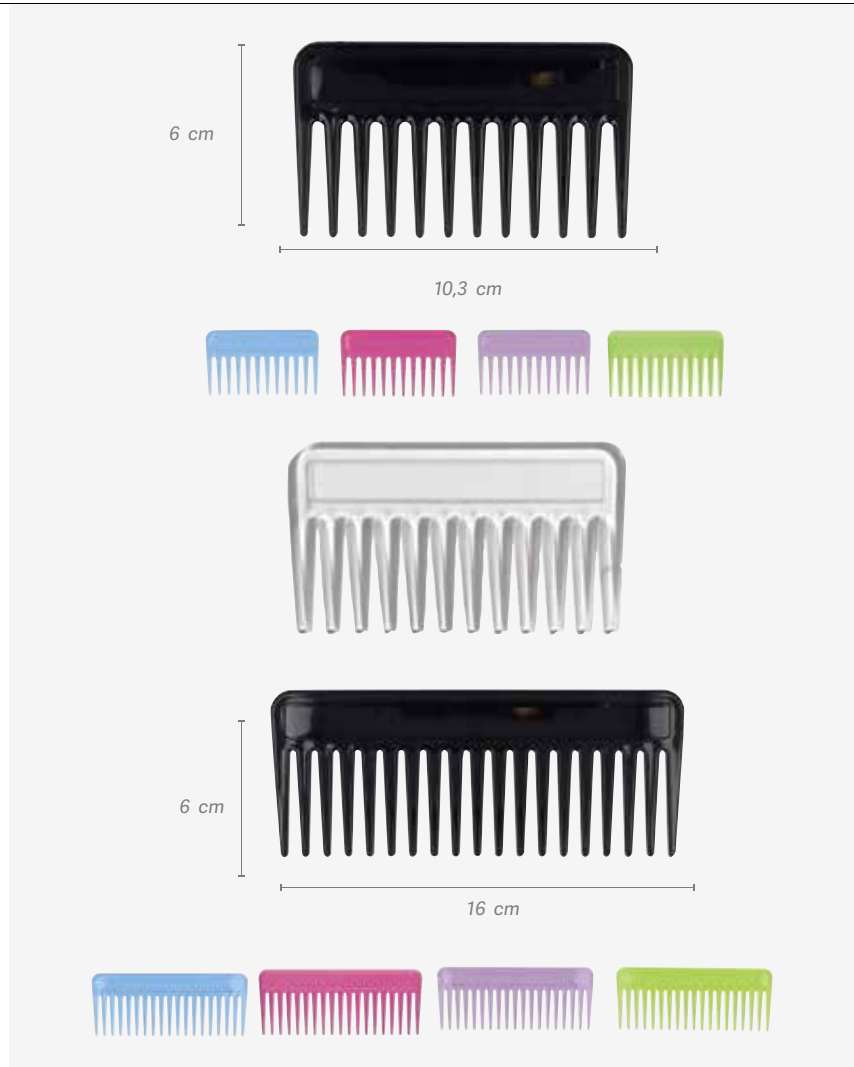
REF. 00426



Peine escalón mechas
Da-tangler step comb

u.m.vta: 12  60 

REF.00421

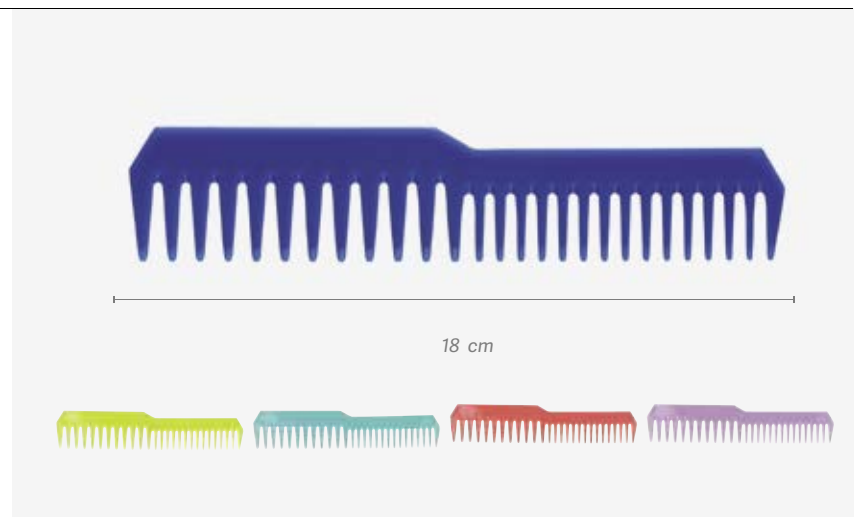

Bote 60 peines colores para crear
Bin 60 teasing coloures combs

u.m.vta: 2  2

Púas de plástico
 Plastic pins

MOD.00423

REF.03251

Colores metalizados
 Metallic colours

MOD.00423

REF.03251/97



Bote 60 peines colores
Bin 60 coloures combs

u.m.vta: 2  2

Púas de plástico
 Plastic pins

MOD.00115

REF.03845

Colores metalizados
 Metallic colours

MOD.00115

REF.03845/97



Bote 60 peines corte
Bin 60 cutting combs

Púas de plástico
 Plastic pins

u.m.vta: 2  2

MOD.00116/99

REF.03250



MOD.00422

REF.03847



Bote 60 peines colores
Bin 60 coloured combs

u.m.vta: 2  2

Púas de plástico
 Plastic pins

MOD.00441

REF.03848



Bote 24 cepillos para crear
Bin of 24 crepe brushes

u.m.vta: 1  20

Púas de plástico. Doble altura
 Plastic pins. Double height

REF.04350



Bote de 60 peines ahuecadores
Bin 60 styling coloures combs

u.m.vta: 2  2

MOD. 00128

REF.03853

Púas de plástico
5 púas metálicas
Plastic pins
5 metal pins



Bote de 24 peines para crepar
Bin 24 teasing combs

u.m.vta: 2  2

MOD. 01469/99

REF.03852

Púas de plástico
5 púas metálicas
Plastic pins
5 metal pins



Bote de 30 cepillos para crepar
Bin 30 teasing brushes

u.m.vta: 2  2

MOD. 03880

REF.04222

Púas de plástico
Colores translúcidos
Plastic pins
Traslucent colours



Bote de 60 peines de colores
Bin 60 coloures combs

u.m.vta: 2  2

MOD. 00118

REF.03850

Púa metálica
Metal pin



Caja de 30 peines de colores surtidos translúcidos**Box 30 combs translucent colours assorted**u.m.vta: 3  3



MOD.00136

REF.01854

Caja plástico
transparente
Transparent plastic box**Bote de 60 peines de colores surtidos transparentes****Bin 60 transparent combs, assorted colours**u.m.vta: 2  2

MOD.00116

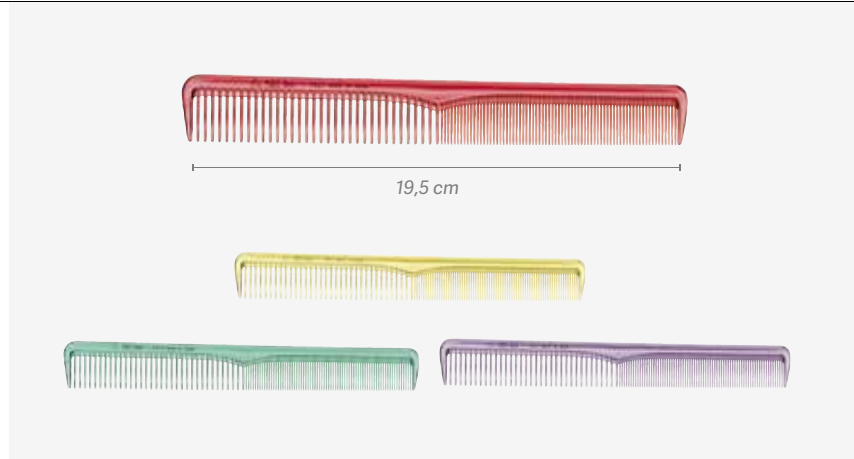
REF.01621

**Bote de 60 peines de colores surtidos transparentes ideales para crepar****Bin 60 transparent combs, assorted colours, ideal for teasing**u.m.vta: 2  2

MOD.00423

REF.01625

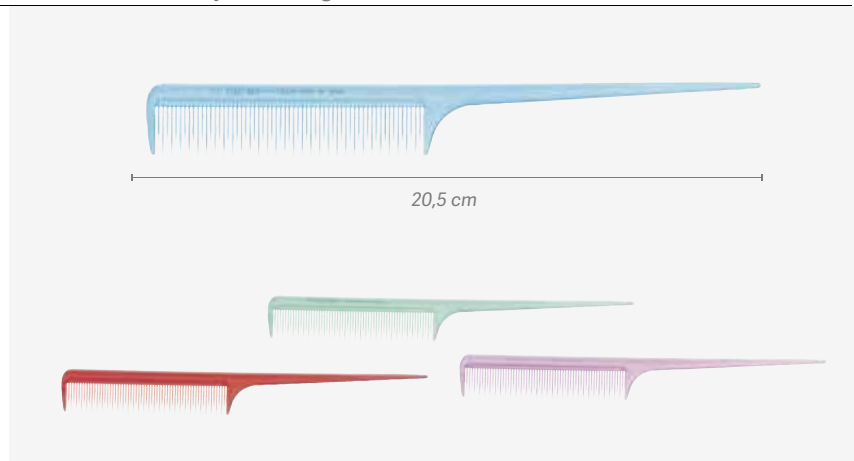



Cepillo para champú masajeador
Massaging shampoo brush

u.m.vta: 1  1 

NEW

REF.07291



u.m.vta: 1  24 

REF.04427

Púas de silicona
Silicone pins



Bote de 12 cepillos para masaje de colores
Bin 12 massage coloured brushes

u.m.vta: 4  4

REF.04403

Púas de plástico
Plastic pins



Bote de 24 cepillos mini neumáticos
Bin 24 mini cushion brushes

u.m.vta: 1  2

REF.02471

Púas de plástico con bola
Plastic pins with ball



Bote de 24 cepillos mini plegables
Bin 24 mini folding brushes



u.m.vta: 1  2

REF.02789

Púas de plástico con bola
Con espejo
Plastic pins with ball
With mirror



Peine escarpidor de color madera
Wood colour da-tangler comb

u.m.vta: 12  48 

REF. 00408/55 Púa curva
Curved pin



17,5 cm

REF. 00407/55 Púa curva
Curved pin





22 cm

REF. 00136/55



22 cm

Peine para mechas
Streak comb

u.m.vta: 12  48 

REF. 00409

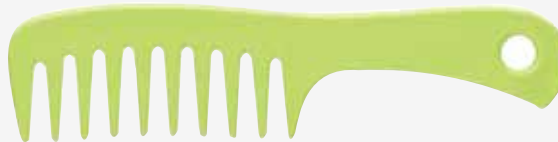

 REF. 00409/50

    
 REF. 00409/99



19 cm

Peine mechas doble púa
Double comb for highlights

u.m.vta: 12  48 



REF. 07290



NEW

Peines de color madera

Wood colour combs

u.m.vta: 12  48 

Peine batidor mechas
Streak comb

REF. 00410



Peine ahuecador 5 púas
Styling comb. 5 pins

REF. 00404





Peine ahuecador 5 púas curvadas
Styling comb 5 pins curved

REF. 00127



Peines de madera

Wooden combs

u.m.vta: 1  12 

Batidor
Cutting

REF. 04241





Escarpidor
Da-tangler

REF. 04240



Peine ahuecador profesional
Professional styling comb

u.m.vta: 6  18 

Doble púa
Double pin

REF. 00450



Peine ahuecador
Styling comb



u.m.vta: 6  60

Doble púa
Double pin

REF.01852





Peine ahuecador
Styling comb

u.m.vta: 6  72 

Doble púa. Pequeño
Double pin. Small

REF. 00417





u.m.vta: 6  60 

Doble púa grande
Double pin, large

REF. 00414





Peine ahuecador para profesional
Professional styling comb

u.m.vta: 6  18 

REF. 00451

Doble púa
Gigante negro
Double pin
Extra-large black





u.m.vta: 6  60 

REF. 00434

Doble púa
Gigante colores
Double pin
Extra-large colours





Peine ahuecador negro
Black styling comb

u.m.vta: 6  72 

REF. 00402/50

REF. 00403/50



u.m.vta: 12  48 

REF. 00432

Plegable
Folding



Peine ahuecador de madera
Wooden styling comb

u.m.vta: 6  72 



REF. 00406

REF. 00402

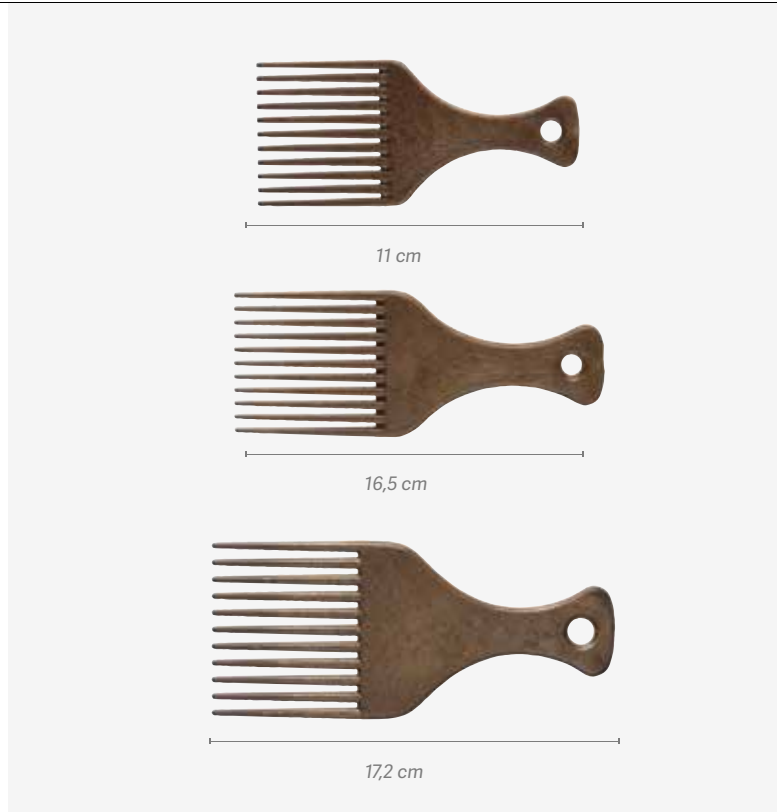
REF. 00403



Peine batidor concha de acetato
Tortoise/acetate cutting comb

u.m.vta: 1  12 



REF. 04238

REF. 04237

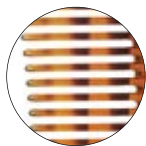
REF. 04239





Peine batidor acetato
Cutting acetate comb

u.m.vta: 1	 12	
------------	--	---

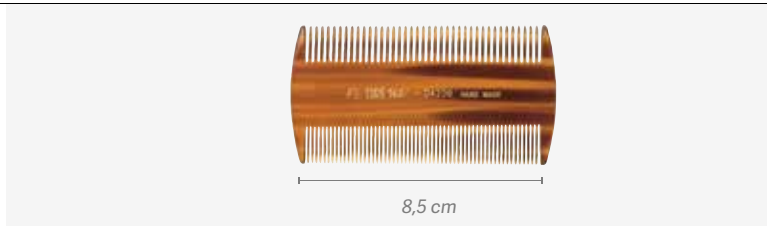
REF. 04236



Peine concha de acetato peluquero
Hairdresser tortoise/acetate comb

u.m.vta: 1	 12	
------------	--	---

REF. 04229

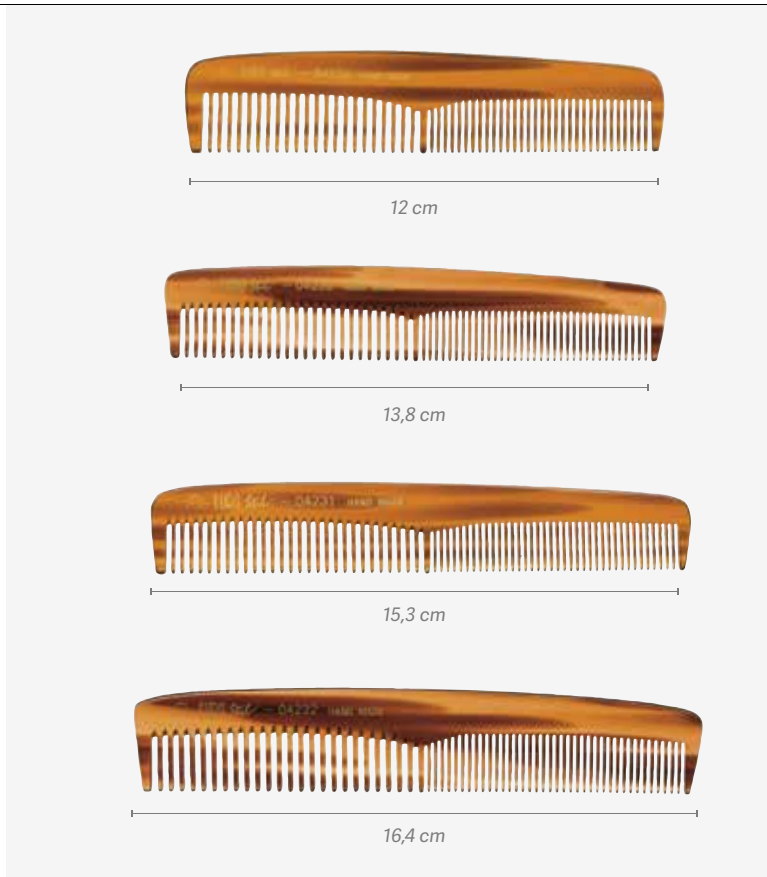



REF. 04230

REF. 04231

REF. 04232

Peine batidor concha de acetato reforzado
Reinforced tortoise/acetate cutting comb



u.m.vta: 1	 12	
------------	--	---

REF. 04233



REF. 04234



Peine concha de acetato
Tortoise/acetate comb

u.m.vta: 12  120 

REF. 00177 Peine batidor
 Cutting comb





13 cm

u.m.vta: 12  60 

REF. 00178 Peine batidor
 Cutting comb





15 cm

u.m.vta: 12  120 

REF. 00179 Peine batidor
 Cutting comb





17 cm

u.m.vta: 12  120 

REF. 00180 Peine batidor
 Acetato
 Cutting comb
 Acetate





19 cm

u.m.vta: 12  120 

REF. 00444/51 Peine escarpidor
 Concha
 Da-tangler comb
 Tortoise



19,5 cm

u.m.vta: 12  60 

REF. 00136/51



22 cm

Comprometidos con el medioambiente
 Línea de productos de material reciclado
 (Fabricación propia)
Committed to the environment
 Recycled material product line
 (own manufacture)



Estudio sostenibilidad productos realizado por la empresa LEITAT como objetivo principal es crear una línea más sostenible de productos. Concretamente el bol ref.00655 reduce su impacto global medioambiental con un 26%, la paletina ref. 00102 un 28%, el peine ref. 00136 un 28% y el peine ref.00409 un 21% con la utilización del polipropileno reciclado.



Utilizar polipropileno reciclado permite reducir los impactos ambientales entre un 25 a un 28%. Los impactos debido a la obtención de materias primas representan entre el 17 al 37% de los impactos en los productos fabricados con polipropileno virgen.

Product sustainability study carried out by the LEITAT company as its main objective is to create a more sustainable line of products. Specifically, the comb ref. 00136 reduces its overall environmental impact with 28%, and the comb ref. 00409 21% with the use of recycled polypropylene.

Using recycled polypropylene reduces environmental impacts by between 25 and 28%. The impacts due to the obtaining of raw materials represent between 17 to 37% of the impacts in products made with virgin polypropylene.

***Puedes encontrar más material reciclado en el capítulo 2: Bol ref.00655 y paletina ref 00102**
***You can find more recycled material in chapter 2: Bowl ref.00655 and brush ref.00102**

Peine batidor polipropileno reciclado
Recycled polypropylene whisk comb

u.m.vta: 12  48 



REF.00409/222



REF.00136/222



Cepillo térmico ECO
ECO thermal brush

u.m.vta: 1  6 

NEW

Ø 25
 REF. 07535



Ø 25



Ø 34
 REF. 07534



Ø 34





Ø 44
 REF. 07533

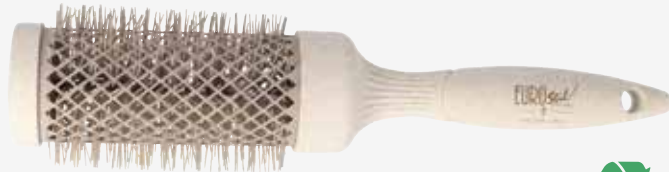

Ø 44



Cepillo oval flexible ECO natural
ECO natural flexible oval brush

u.m.vta: 1  6 

NEW

REF. 07537



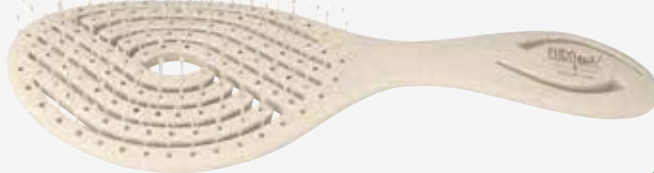

REF. 07539



Cepillo rectangular fuele eco

Eco bellows rectangular brush



u.m.vta: 1		6	
------------	---	---	---

REF. 07540



Cepillo oval fuele eco

Eco bellows oval brush

u.m.vta: 1		6	
------------	---	---	---

REF. 07541



ECO Friendly



Cruelty Free



Compostable



Natural Fibers

Material Fibras naturales. Ideales para cabello Fino

Elaborado con los mejores productos y componentes totalmente naturales para minimizar el impacto negativo en el medio ambiente.

- El cepillo más ECO. Cepillo elaborado a base de materiales naturales: reciclable, reusable y sostenible.
- ERGONÓMICO: la forma semicurva, en combinación con el largo de las púas, se adapta mejor a la cabeza y permite peinar mayor cantidad de cabellos en cada pasada.
- ANTIENTREDOS-ANTITIRONES Púas antienredos, flexibles y resistentes. Permiten desenredar con la máxima suavidad.
- SOSTENIBLE: Aporta una experiencia eco-friendly al cepillado diario
- PARA CABELLO HÚMEDO O SECO: especialmente cabello fino. No utilizar con secador muy cerca.

Elaborado en materiales naturales renovables naturales. Diseño ergonómico que facilita un desenredado suave, sin tirones. Con el cabello seco o húmedo se desliza fácilmente.

Material Natural fibers. Ideal for thin hair

Made with the best products and totally natural components to minimize the negative impact on the environment

- The most ECO brush. Brush made from natural materials: recyclable, reusable and sustainable.
- ERGONOMIC: the semi-curved shape, in combination with the length of the bristles, adapts better to the head and allows combing more hair in each pass.
- ANTI-TANGLING-ANTI-SHOOTING Anti-tangle, flexible and resistant bristles. They allow untangling with maximum softness.
- SUSTAINABLE: Provides an eco-friendly experience to daily brushing
- FOR WET OR DRY HAIR: especially fine hair. Do not use with hair dryer too close

Made of natural renewable natural materials. Ergonomic design that facilitates smooth detangling, without pulling. With dry or damp hair it glides easily.

09

Rulos, rellenos y gorros Rollers, bun stuff & craps

*Rulos, bigudías, pinchitos,
papillots, redes, gorros...*

*Rollers, hair curlers,
papillots, caps...*

Bolsa 12 bigudíes madera estriada
Bag 12 fluted wooden hair curlers



u.m.vta: 1  1

∅ 5 ∅ 6,5
 REF.01544 REF.01546

∅ 8 ∅ 12,5
 REF.01548 REF.01571





Bolsa 6 bigudíes madera
Bag 6 wooden hair curlers

u.m.vta: 1  52 u.m.vta: 1  32

∅ 10,5 ∅ 18
 REF.01573 REF.01550



Bolsa 10 bigudíes madera estriada
Bag 10 fluted wooden hair curlers

u.m.vta: 1  160 u.m.vta: 1  120

∅ 6 ∅ 8
 REF.01559 REF.01560

u.m.vta: 1  90 u.m.vta: 1  60

∅ 10 ∅ 12
 REF.01561 REF.01562



Bolsa 12 bigudíes
Bag 12 hair curlers

u.m.vta: 12  12

Plástico, bicolor ondulado
Plastic, bicolour and wavy

REF.01500



REF.01501



REF.01502



REF.01503



REF.01504



Bolsa 100 bigudíes
Bag 100 hair curlers

u.m.vta: 1  12

Plástico
Plastic

REF.01554



REF.01555



REF.01556



REF.01557

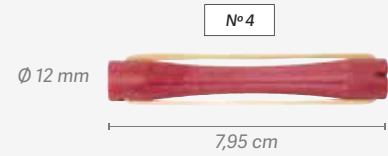

REF.01558



Bolsa de 50 gomas para bigudíes
Bag 50 elastic for hair curlers

u.m.vta: 1  50

Silicona. Cortas
 Silicone . Short

REF.01490

u.m.vta: 12  12

Redondas. Cortas
 Round. Short

REF.00863

u.m.vta: 12  12

Redondas. Largas
 Round. Long

REF.00862

u.m.vta: 12  12

Planas. Cortas
 Flat. Short

REF.00865

u.m.vta: 12  12

Planas. Largas
 Flat. Long

REF.00864



Anillas bigudíes 100 gr
Hair curlers rings 100 gr

u.m.vta: 1  50 

REF.00653



Para bigudíes madera
 For wooden hair curlers

Bolsa 50 gomas recambio
Bag 50 replacement elastic bands

u.m.vta: 1  1



REF.00867



Para bigudíes madera
 For wooden hair curlers

Bolsa 12 bigudíes plástico
Bag 12 plastic hair curlers

Bicolor
 Bicolour

u.m.vta: 12  12 

Cortos
Short

Largos
Long

REF.00907

REF.00900

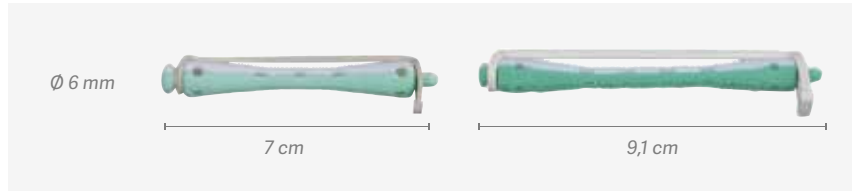

REF.00908

REF.00901

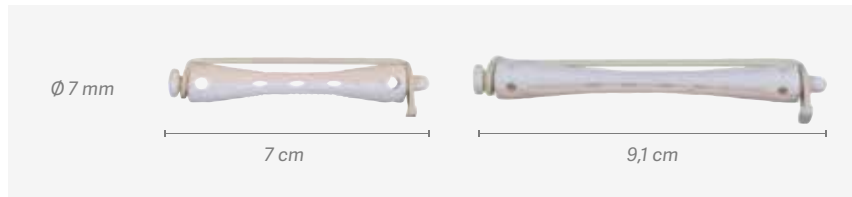

REF.00909

REF.00902



REF.00910

REF.00903

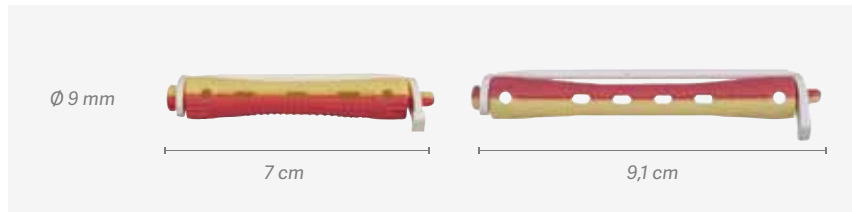

REF.00911

REF.00904

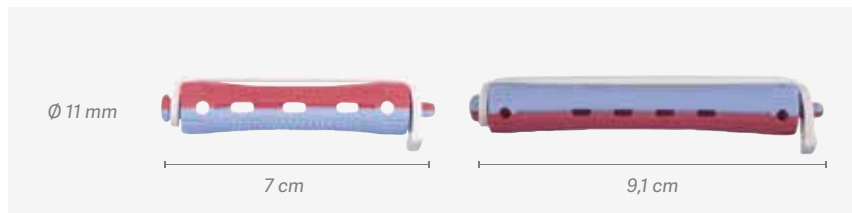

REF.00912

REF.00905

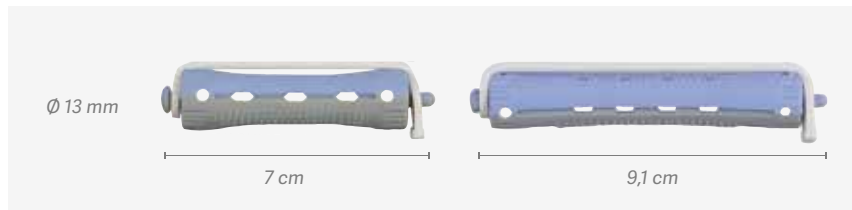

REF.00913

REF.00906



Papillots largos y cortos: 12 unidades
Long and short coils: 12 units

u.m.vta: 1  12 



Cortos
Short

Largos
Long

REF. 01251

REF. 01244

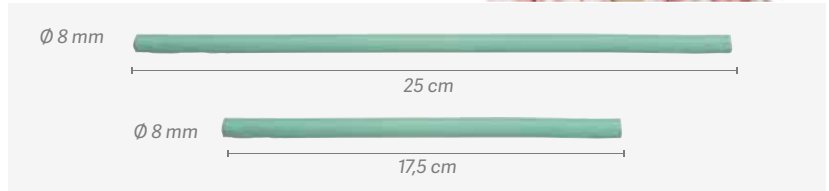

REF. 01252

REF. 01245



REF. 01253

REF. 01246

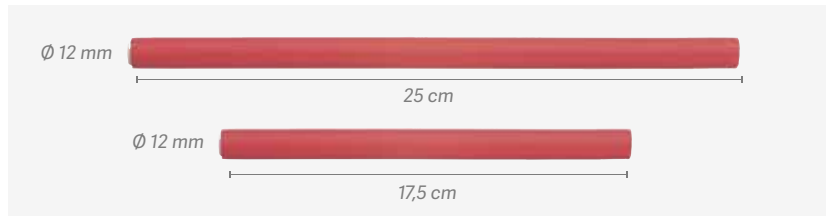

REF. 01254

REF. 01247



REF. 01255

REF. 01248



REF. 01256

REF. 01249





REF. 01257

REF. 01250





Bolsa 6 rulos malla
Bag 6 mesh rollers

u.m.vta: 1  12 

NEW



Ø 13 mm
REF. 07763



Ø 16 mm
REF. 07764



Ø 20 mm
REF. 07765

Ø 24 mm
REF. 07766

Ø 28 mm
REF. 07767



Ø 32 mm
REF. 07768

Ø 36 mm
REF. 07769

Ø 40 mm
REF. 07770



Bolsa 6 rulos malla negros
Bag 6 black mesh rollers

u.m.vta: 1  12 

Ø 28 mm

REF. 07337



Ø 36 mm

REF. 07339



Ø 32 mm

REF. 07338



Ø 45 mm

REF. 07340

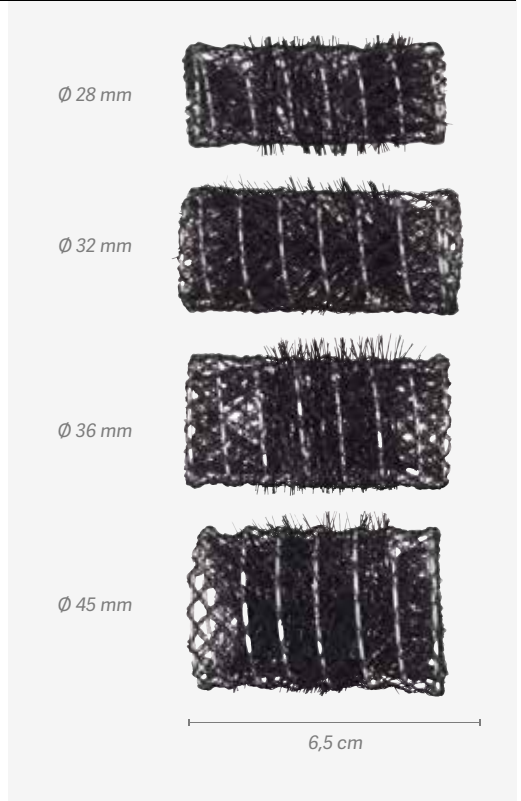

Bolsa 6 rulos malla
Bag 6 mesh rollers

u.m.vta: 1  12 

Azul
 Blue

Ø 10 mm

REF. 07333



Rosa
 Pink

Ø 13 mm

REF. 07334



Lila
 Lilac

Ø 17 mm

REF. 07335



Rosa
 Pink







Ø 22 mm

REF. 07336



Bolsas rulos adherentes

Adherent rollers bags

u.m.vta: 1  80 	u.m.vta: 1  70 	u.m.vta: 1  45 
---	---	---

Verdes
Green

9u 

REF. 00015

Naranja
Orange



8u 

REF. 00016

Amarillos
Yellow

8u 



REF. 00017

u.m.vta: 1  40 

Rojos
Red

6u 



REF. 00018

u.m.vta: 1  25 

Azul
Blue

5u 



REF. 00047

u.m.vta: 1  20 

Lila
Lilac

5u 

REF. 00024

u.m.vta: 1  16 

Rosa
Pink

4u 

REF. 00025



Bolsa 12 rulos espuma

Bag 12 foam rollers

u.m.vta: 1  30 	u.m.vta: 1  12 
---	---

 REF. 04019

 REF. 04021

 REF. 04020

 REF. 04023



Bolsa rulos calientes
Hot rollers bag

Atención, no usar en microondas
Warning, not use in microwave

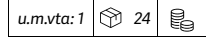

6 u

REF. 00019

6 u

REF. 04024

5 u

REF. 00020

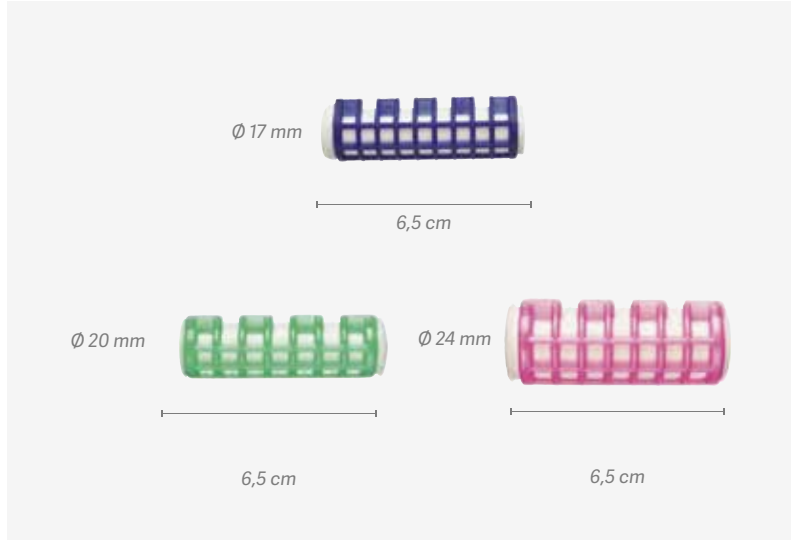

Caja rulos calientes
Hot rollers box

Atención, no usar en microondas
Warning, not use in microwave

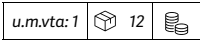

6 u

REF. 03391

6 u

REF. 03392

5 u

REF. 03393

4 u

REF. 03394



Kit rizador pelo 60 bucles
Hair curler kit 60 pics

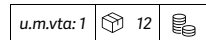

12 bucles por 5 medidas
12 pics for 5 measurements

60 u

REF. 04428



Bolsa de 12 rulos en rosa traslúcido
Bag 12 translucent pink rollers

u.m.vta: 12 120 u.m.vta: 12 72

Nº0

Nº1

REF. 00000

REF. 00001

u.m.vta: 12 240

u.m.vta: 12 144

Nº2

Nº3

REF. 00002

REF. 00003

u.m.vta: 12 120

u.m.vta: 12 72

Nº4

Nº5

REF. 00004

REF. 00005

u.m.vta: 12 60

u.m.vta: 12 48

Nº6

Nº7

REF. 00006

REF. 00007

u.m.vta: 12 24

Nº8

REF. 00008



Los rulos rosas fabricados en Industrias Oriol son un clásico muy valorado a lo largo de todos los años de historia de la empresa.
The pink hair rollers manufactured by Industrias Oriol have remained a well-beloved classic throughout the long history of our company.

Bolsa 12 rulos extra fuertes (incluyen bolsa con pinchitos)
Bag 12 extra strong rollers (include bag with sticks)

u.m.vta: 12  12

Especial cabellos afro y cabellos resistentes
 Special afro hair and resistant hair



REF. 04669



REF. 04670



REF. 04668



REF. 04667





REF. 04665



REF. 04666





Bolsa 12 rulos súper adherentes (los colores pueden variar)
Bag 12 super adherent rollers (the colours can vary)

u.m.vta: 1  16 

REF. 04003



Bolsa 6 rulos súper adherentes
Bag 6 super adherent rollers

u.m.vta: 12  120 

Ø 13mm

REF.00009

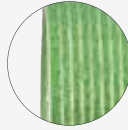

Ø 13mm

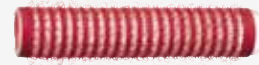

6,3 cm

Ø 15 mm

REF.00031

Ø 21 mm

REF.00010

Ø 15 mm



6 cm

Ø 21 mm



6,3 cm

Ø24 mm

REF.00011

Ø 28 mm

REF.00012



6,3 cm



6,3 cm

Ø 32 mm

REF.00013

Ø 36 mm

REF.00014

Ø 32 mm





6,3 cm



6,3 cm



Bolsa 3 rulos súper adherentes
Bag 3 super adherent rollers

u.m.vta: 12  120 

Ø 40 mm

REF.00028

Ø 44 mm

REF.00032

Ø 48 mm

REF.00033

Ø 60 mm

REF.00034



Bolsa pinchitos
Sticks bag

u.m.vta: 1  50

Metálicos largos
 Long metallic

100 u

REF.01495

Pinchitos clavo
 Sticks nail

36 u

REF. 00649



Nylon
 Nylon

36 u

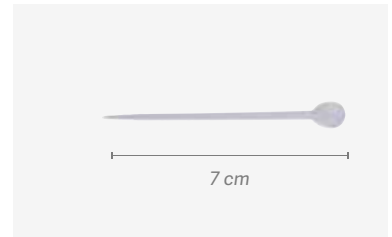
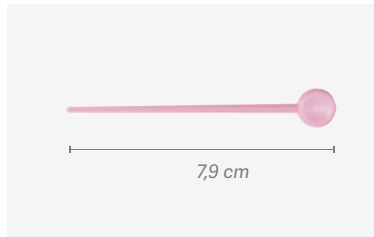
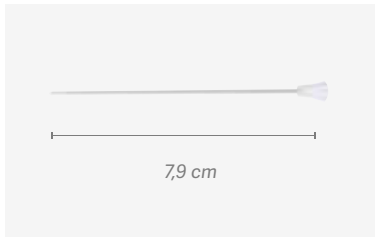
REF. 00648



Caja pinchitos
Sticks box

u.m.vta: 1  16 

300 u

REF. 03329



Nylon
 Nylon

Gorro noche sin cinta
Night cap without ribbon

u.m.vta: 12  12

Negro
 Black

REF.01049/50



u.m.vta: 12  12

Castaño oscuro
 Dark brown

REF.01049/67



u.m.vta: 12  12

Castaño natural
 Natural brown

REF.01049/76



u.m.vta: 12  12

Castaño claro
 Light brown

REF.01049/65



u.m.vta: 12  12

Rosa
 Pink

REF.01049/70



u.m.vta: 12  12

Azul
 Blue

REF.01049/59

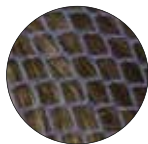

Red secador triangular
H.D. net triangle

u.m.vta: 12  12



REF.01044/50



REF.01044/69

Elástica
Elastic



90 x 72 x 72 cm



u.m.vta: 12  12



REF.01042/59

Calada con ribete
Edged

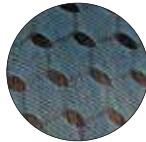

80 x 70 x 70 cm



REF.01042/69



REF.01042/68

u.m.vta: 12  12



REF.01039/50



REF.01039/59

Sin ribete
No edged



83 x 74 x 74 cm



REF.01039/69



REF.01039/70

u.m.vta: 12  12



REF.01041/50



REF.01041/59

Con ribete
Edged

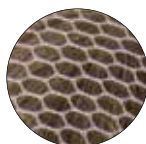

83 x 74 x 74 cm



REF.01041/69



REF.01041/70

Gorro noche
Night cap

u.m.vta: 12  12

Con cinta
Ribbon



REF.01048/50 REF.01048/59

REF.01048/69 REF.01048/70



u.m.vta: 12  12

Nylon
Surtido colores
Nylon
Assorted colours

REF.01053

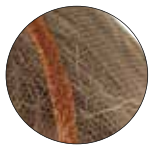

u.m.vta: 12  60

Nylon
Nylon
REF.01539

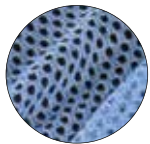

u.m.vta: 12  60

Nylon con cinta
Nylon with ribbon

REF.01538

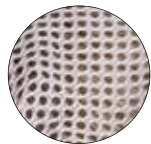

Gorro ducha
Shower cap

u.m.vta: 12  60

Estampado
Printed

REF.01542



u.m.vta: 12  60

Plástico
Permanente 3 piezas
Plastic
Permanent 3 pieces
REF.00967



Gorro ducha
Shower cap

u.m.vta: 12  60



REF.01227



REF.01227/58





u.m.vta: 200  200

Un solo uso
Disposable

REF.01540



Bolsa de gorros mechas
Bag streaks caps



u.m.vta: 12  12 

Doble capa
Double layer

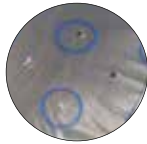
REF. 01290



5 u

u.m.vta: 1  30 

Ribete negro
Black border

REF.02532/50

u.m.vta: 1  50

Con gancho
With hook

REF.00973



10 u

50 u



Gorros mechas caucho
Streaks caps rubber

Marrón
 Brown



u.m.vta: 1  10 

REF. 00896



Gorros mechas silicona con ganchillo
Streaks rubber caps silicone with hook

Traslúcido
 Translucent

u.m.vta: 12  80 

REF. 02196



u.m.vta: 1  60 

REF. 03402



u.m.vta: 1  5

Perforado
 Drill

REF.06460



Gorros mechas silicona
Streaks rubber caps silicone

u.m.vta: 1  10 



REF. 03729



u.m.vta: 1  12 



REF. 00897



u.m.vta: 1  10 

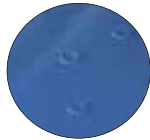

REF. 00894

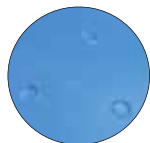

u.m.vta: 1  10 

REF. 01511





u.m.vta: 1  20 

REF. 01995



Bolsa ganchillos

Bag hooks



u.m.vta: 1  12 

6 u

REF. 01266



- Medianos
- Medium

u.m.vta: 1  12 

3 medidas
3 sizes

3 u



REF. 01265

Ø 0,75 mm Ø 1 mm Ø 1,25 mm



Peine especial mechas

Streaks special comb

u.m.vta: 1  60 

REF. 00440



Bolsa ganchos mechas

Bag streaks hooks

u.m.vta: 1  125 



Doble
Double

REF. 01966



Peine púa metal gancho mechas

Tail comb metallic with hook for streaks

u.m.vta: 12  120 

REF. 00473



Las mechas a gorro son una alternativa para dar luz al cabello ya sea decolorándolo o con tinte.

Using the cap method to highlight hair is an alternative to provide it with light either by bleaching or with dye.

Gorros Caps

u.m.vta: 12  12

Plástico "MACRO"
"MACRO" Plastic

REF.00966



u.m.vta: 10  10

Aluminio
Aluminium

REF.02534





u.m.vta: 6  6

Térmico para secador
Thermal for hair dryer

REF.03189



Gorro toalla Towel cap

u.m.vta: 1  10 

Con goma y botón
100% algodón
With rubber and button
100% cotton

REF. 03404

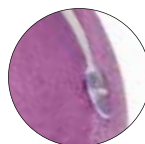

REF. 04433



Redes invisibles
Invisible hairnets

u.m.vta: 12  12

 **REF.01046/50** Nylon
Nylon

 **REF.01046/65**  **REF.01046/67**

 **REF.01046/66**  **REF.01046/76**

Nylon moño
Nylon bun

 **REF.01047/50**  **REF.01047/66**



 **REF.01047/65**  **REF.01047/69**

 **REF.01045/50** Pelo natural
Natural hair

 **REF.01045/69**  **REF.01045/66**



Relleno moño circular
Circular hair bun stuff

u.m.vta: 1  12 



REF. 03001/50



REF. 03001/67





REF. 03001/65

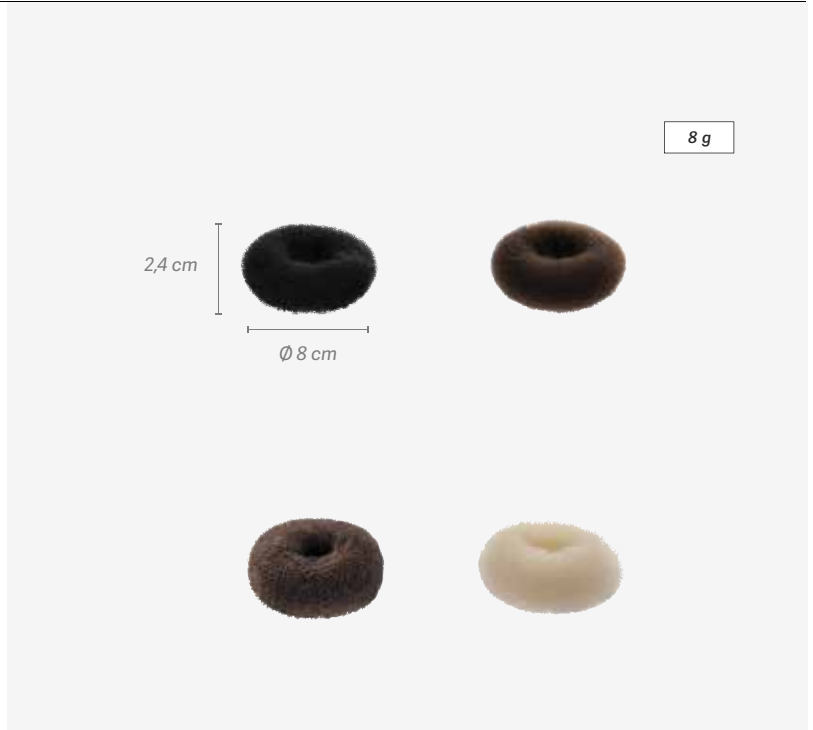

REF. 03001/66



u.m.vta: 1  12 



REF.04435/50





REF.04435/65



REF.04435/66



Relleno moño circular
Circular hair bun stuff

u.m.vta: 1  12 



REF.04436/50



REF.04436/65



REF.04436/66



REF.04437/50



REF.04437/65



REF.04437/66



Relleno moño
Hair bun stuff



u.m.vta: 1  12 

 **REF. 03002/50**  **REF. 03002/67**

 **REF. 03002/65**  **REF. 03002/66**



Relleno moño con goma
Hair bun stuff with elastic



u.m.vta: 1  12 

 **REF.04434/50**

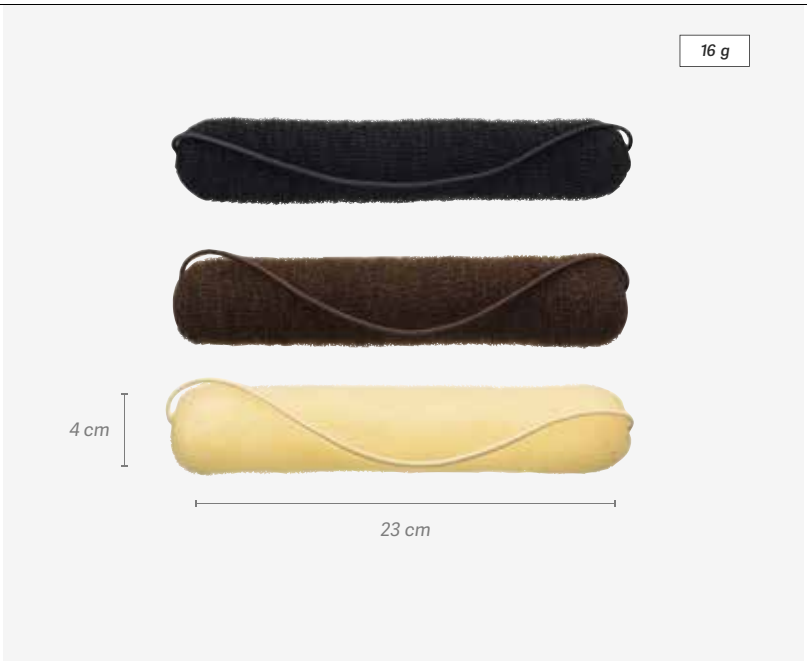
 **REF.04434/65**  **REF.04434/66**



Relleno moño grande alargado
Large and long hair bun stuff



u.m.vta: 1  8 

 REF. 03636/50

 REF. 03636/65  REF. 03636/66



Relleno moño grande redondo
Large and round hair bun stuff

u.m.vta: 1  8 

 REF. 03635/50

 REF. 03635/65  REF. 03635/66



¿Cómo usar? - How to use?



1. Haga una coleta
1. Make a ponytail



2. Pase la coleta por el aro y sujételo con horquillas
2. Pull ponytail through the ring and secure firmly with pins



3. Aplique un poco de laca y enrolle el cabello alrededor del aro
3. Apply a little hairspray, wrap it around the ponytail holder



1. Coloque el relleno en la coronilla
1. Crown the stuff with toupee clips



2. Sujete el relleno
2. Secure stuff at crown area



3. Recubra el relleno con los cabellos de la parte delantera y sujételo con horquillas
3. Pull front hair to cover stuff and secure it with pins



10

Navajas y tijeras Scissors & razors

Tijeras, estuches...

Scissors, cases...

Tijera profesional EXCELSIOR

EXCELSIOR Professional Scissors

u.m.vta: 1  10Corte
Cutting

5,5"

REF.04900

- Material: acero japonés VG10
- Dureza: 63HRC
- Borde: convexo
- Mango: offset

- Material: Japanese steel VG10
- Toughness: 63HRC
- Edge: convex
- Handle: offset



Tijeras INFINITY

INFINITY scissors

u.m.vta: 1  10

5,5"

Corte
Cutting

REF.06976

5,5"



6"

Corte
Cutting

REF.06977

6"



6"

Esculpir
Thinning

REF.06978

6"



- Material: acero 440C
- Dureza: 60 HRC
- Mango: offset

- Material: steel 440C
- Hardness: 60 HRC
- Handle: offset



Tijeras AMATIST
AMATIST scissors

Incluye: aceite, gamuza, aros de goma y llave para apretar
 It includes: oil, suede, rubber rings ond tightening wrench

u.m.vta: 1  10

REF.06970 Corte
 Cutting

5,5"



REF.06971 Corte
 Cutting

6"



REF.06972 Esculpir
 Thinning

6"



- Material: acero 440C
- Dureza: 60 HRC
- Mango: Offset

- Material: steel 440C
- Hardness: 60 HRC
- Handle: Offset

Tijeras OASIS
OASIS scissors

u.m.vta: 1  10

REF.06973 Corte
 Cutting

5,5"



REF.06974 Corte
 Cutting

6"



REF.06975 Esculpir
 Thinning

6"



- Material: acero 440C
- Dureza: 60 HRC
- Mango: Offset

- Material: steel 440C
- Hardness: 60 HRC
- Handle: Offset



- Acero 440
- Afilado navaja
- Acabado Manual
- Gran dureza 59.61 HRC
- Tornillos de ajuste
- Estuche individual

- 440 steel
- Razor sharpened
- Hand-finished
- High level of hardness: 59.61 HRC
- Adjustment screws
- Individual pouch



Tijera SHARK
SHARK scissors

u.m.vta: 1 10

Corte
Cutting

5,5"

REF. 04627

Esculpir
Thinning

5,5"

REF. 04628



Tijera PIRATA
PIRATA scissors

u.m.vta: 1 10

REF. 04630

Corte
Cutting



Tijera DARK
DARK scissors

u.m.vta: 1 10

REF. 04629

Corte
Cutting



Estuche muestrario porta-tijeras
Scissors holder case

u.m.vta: 1 1

6 unidades
6 units

REF.04633



Tijeras ATENEA
ATENEA scissors

No incluye: aceite, gamuza, aros de goma ni llave para apretar
Not included: oil, suede, rubber rings or tightening wrench

u.m.vta: 1  12

Corte
Cutting

REF.07020/68

Esculpir
Thinning

REF.07021/68

Corte
Cutting

REF.07020

Esculpir
Thinning

REF.07021

Corte
Cutting

REF.07020/70

Esculpir
Thinning

REF.07021/70

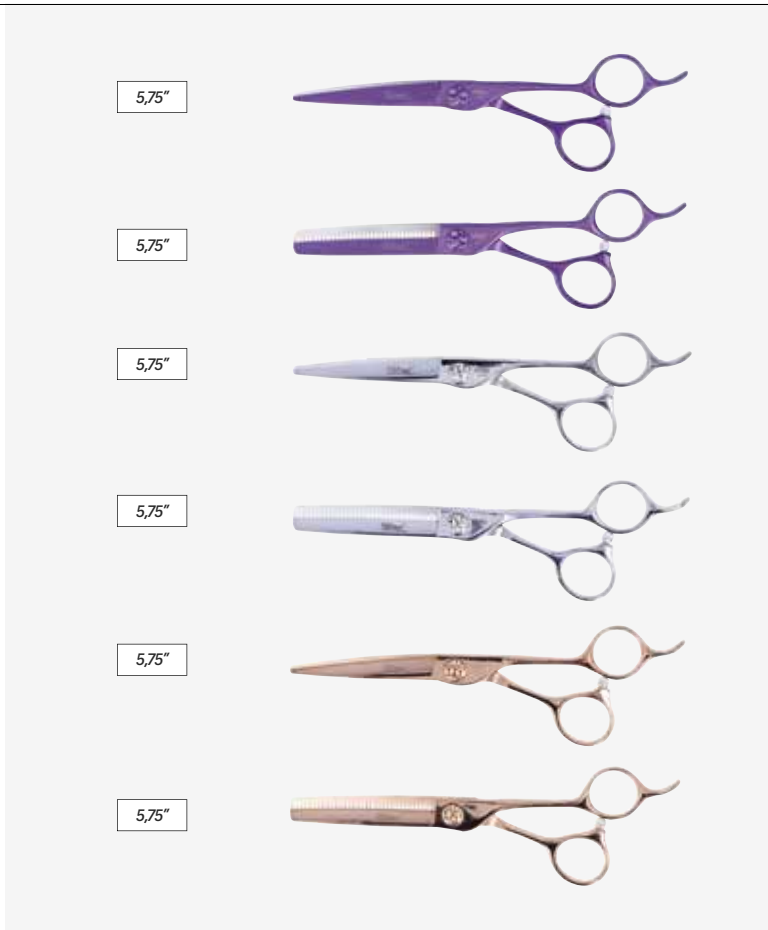

- Material: acero martensítico 420J2
- Dureza: 56HRC

Material: martensitic steel 420J2
Hardness: 56HRC

Tijeras AFRODITA
AFRODITA scissors

No incluye: aceite, gamuza, aros de goma ni llave para apretar
Not included: oil, suede, rubber rings or tightening wrench

u.m.vta: 1  12

Corte
Cutting

REF.07022/70

Corte
Cutting

REF.07022



- Material: acero 440C
- Dureza: 59-61 HRC

Material: steel 440C
Hardness: 59-61 HRC



Tijeras ISIS
ISIS scissors

No incluye: aceite, gamuza, aros de goma ni llave para apretar
Not included: oil, suede, rubber rings or tightening wrench

u.m.vta: 1 12

REF.07023

Corte
Cutting

6"

REF.07024

Esculpir
Thinning

6"

REF.07023/70

Corte
Cutting

6"

REF.07024/70

Esculpir
Thinning

6"

- Material: acero martensítico 420J2
- Dureza: 56HRC

Material: martensitic steel 420J2
Hardness: 56HRC

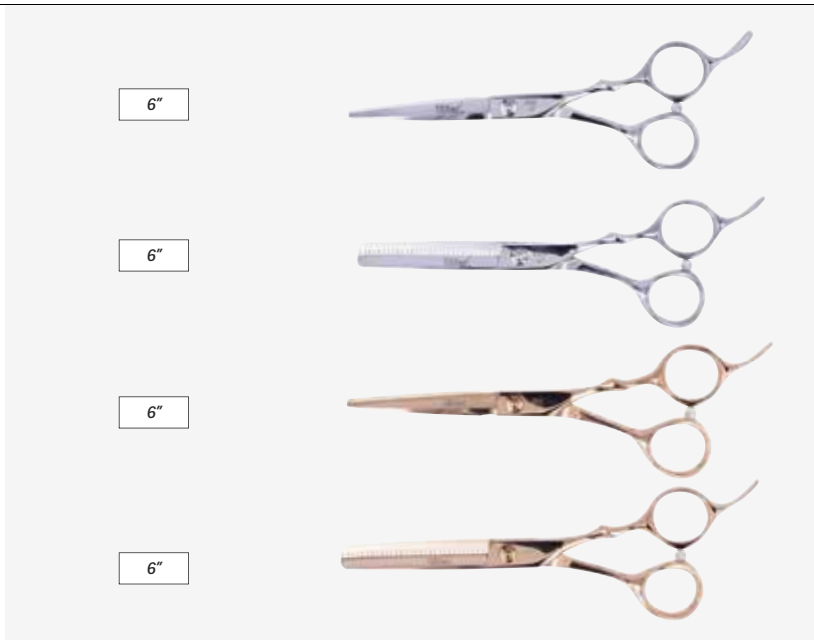

Tijeras MINERVA
MINERVA scissors

No incluye: aceite, gamuza, aros de goma ni llave para apretar
Not included: oil, suede, rubber rings or tightening wrench

u.m.vta: 1 12

REF.07026

Corte
Cutting

6"

REF.07025

Esculpir
Thinning

6"

REF.07026/70

Corte
Cutting

6"

REF.07025/70

Esculpir
Thinning

6"

- Material: acero martensítico 420J2
- Dureza: 56HRC

Material: martensitic steel 420J2
Hardness: 56HRC

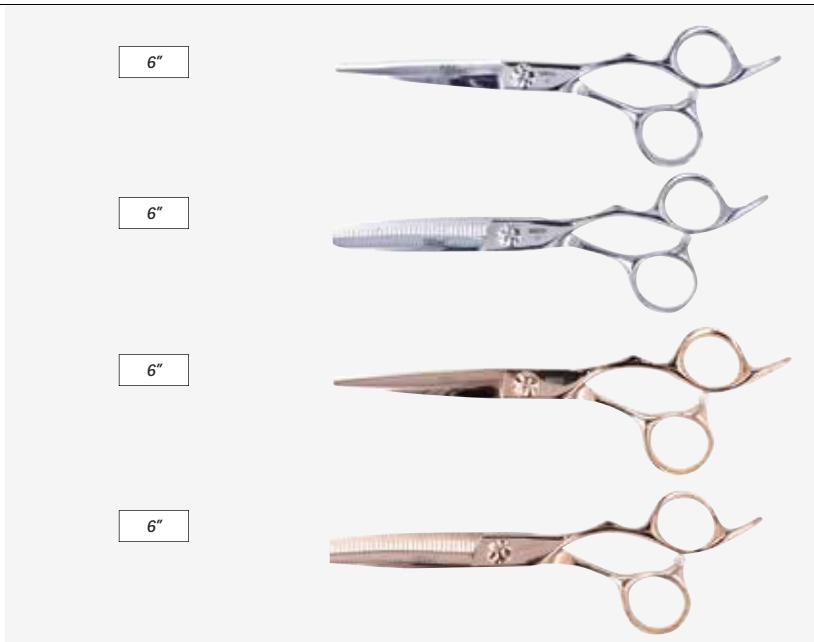

Tijeras ECLIPSE
ECLIPSE scissors

No incluye: aceite, gamuza, aros de goma ni llave para apretar
Not includes: oil, suede, rubber rings or tightening wrench

u.m.vta: 1  12

REF.07027/68 Corte
Cutting

6"



REF.07054/68 Esculpir
Thinning

6"



REF.07027 Corte
Cutting

6"



REF.07054 Esculpir
Thinning

6"



REF.07027/70 Corte
Cutting

6"



REF.07054/70 Esculpir
Thinning

6"



- Material: acero martensítico 420J2
- Dureza: 56HRC

Material: martensitic steel 420J2
Hardness: 56HRC



Tijera acero WAVES
WAVES steel scissors

u.m.vta: 1  12

REF.04316 Corte
 Cutting

REF.04317 Esculpir
 Thinning



Tijera profesional ERGO
ERGO professional scissors



u.m.vta: 1  12

REF.04314 Corte
 Cutting

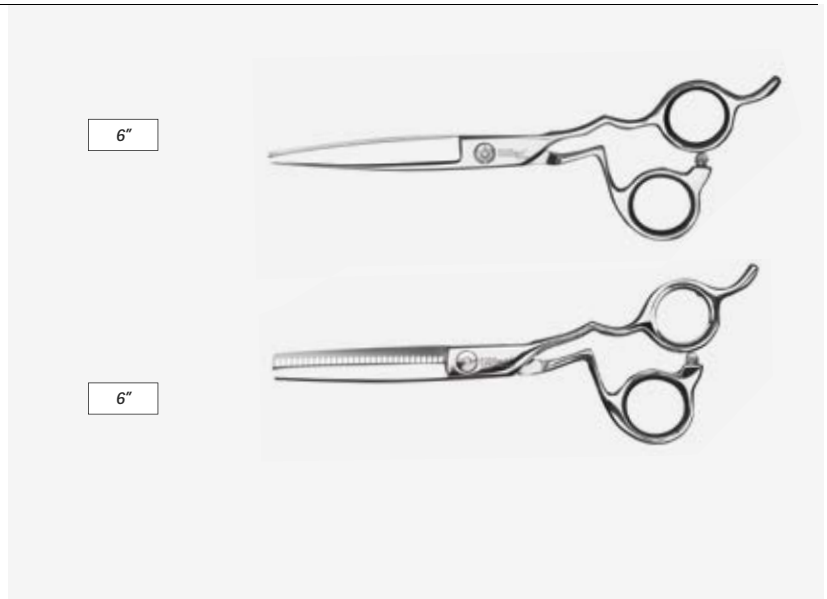
REF.04315 Esculpir
 Thinning



Tijera filo navaja con rabillo WILL
WILL scissors with razor edge and finger rest

u.m.vta: 1  12 

REF. 04707

Corte
Cutting

5,5"



REF. 04708

Corte
Cutting

6"



REF. 04709

Esculpir
Thinning

6"



Tijera filo navaja para ZURDOS (plata mate)
LEFT HANDED scissors with razor edge (matte silver)

u.m.vta: 1  12

REF.04503

Corte
Cutting

5,5"



REF.04504

Esculpir
Thinning

5,5"



Tijera para ZURDOS
LEFT HANDED scissors

u.m.vta: 1  30

REF.02213

Corte
Cutting

5,5"



Tijeras COSMOS LINE
COSMOS LINE scissors

u.m.vta: 1  12

REF.06815 Corte
 Cutting

REF.06816 Corte
 Cutting

REF.06817 Esculpir
 Thinning



5,5"



6"



6"



- Material: acero martensítico 4cr
- Dureza: 51-52hrc- acabado: mate
- Apoya dedos extraíble.Hoja convexa

*Material: martensitic steel 4Cr
 Hardness: 51-52HRC.-Finish:matte
 Supports removable fingers. Convex sheets*

Tijeras EVOLUTE LINE
EVOLUTE LINE scissors

u.m.vta: 1  12

REF.07101 Corte
 Cutting

REF.07102 Corte
 Cutting

REF.07103 Esculpir
 Thinning



5,5"



6"



6"



- Material: acero martensítico 4Cr
- Dureza: 51-52HRC- Acabado: mate
- Apoya dedos extraíble.Hoja convexa

*Material: martensitic steel 4Cr
 Hardness: 51-52HRC.- Finish:matte
 Supports removable fingers. Convex sheet*

Tijeras UTILE LINE
UTILE LINE scissors

u.m.vta: 1  12

REF.07104 Corte
 Cutting

REF.07105 Corte
 Cutting



REF.07106 Esculpir
 Thinning



Material: acero martensítico 4Cr
 Dureza: 51-52HRC- Acabado: mate
 Apoya dedos extraíble.Hoja convexa

Material: martensitic steel 4Cr
 Hardness: 51-52HRC.- Finish:matte
 Supports removable fingers Convex sheet

Tijeras CORVUS LINE
CORVUS LINE scissors

u.m.vta: 1  10 

REF.06818 Corte
 Cutting

REF.06819 Corte
 Cutting

REF.06820 Esculpir
 Thinning



Accesorios: aceite, dos anillas de caucho para dedos
 Accessories: oil, two rubber finger rings



 Microdentado
 Micro-serrated

Material: acero martensítico 420
 Dureza: 51-52HRC - Acabado: mate
 Apoya dedos extraíble

Material: martensitic steel 420
 Hardness: 51 - 52HRC- Finish:matte
 Supports removable fingers

Tijeras SCULPTOR LINE
SCULPTOR LINE scissors

Accesorios: aceite, dos anillas de caucho para dedos
 Accessories: oil, two rubber finger rings

u.m.vta: 1  10 

REF.06822 Corte
 Cutting

REF.06823 Corte
 Cutting

REF.06824 Esculpir
 Thinning



5,5"



6"



6"



 Microdentado
 Micro-serrated

Material: acero martensítico 420
 Dureza: 51-52HRC - Acabado: mate
 Apoya dedos extraíble

Material: martensitic steel 420
 Hardness: 51.52HRC- Finish:matte
 Supports removable fingers

Tijeras LOYAL
LOYAL scissors

Accesorios: aceite, dos anillas de caucho para dedos
 Accessories: oil, two rubber finger rings

u.m.vta: 1  5

REF.07119 Corte
 Cutting

REF.07120 Corte
 Cutting

REF.07121 Esculpir
 Thinning



5,5"



6"



6"



 Microdentado
 Micro-serrated

Material: acero martensítico 420J2
 Dureza: 52-54HRC - Acabado: mate
 Apoya dedos extraíble

Material: martensitic steel 420J2
 Hardness: 52.54HRC- Finish:matte
 Supports removable fingers

Tijeras NEOSTAR
NEOSTAR scissors



Microdentado
Micro-serrated

u.m.vta: 1  10

REF.06964 Corte
Cutting

5,5"



REF.06965 Corte
Cutting

6"



REF.06966 Esculpir
Thinning

5,5"



REF.06964/70 Corte
Cutting

5,5"



REF.06965/70 Corte
Cutting

6"



REF.06966/70 Esculpir
Thinning

5,5"



Material: acero martensítico 420J2
Dureza: 56HRC

Material: martensitic steel 420J2
Hardness: 56HRC

Tijera inoxidable SATINY
SATINY stainless scissors



Microdentada de una hoja
Micro-serrated one blade

u.m.vta: 1  30

REF.00725 Corte
Cutting

5,5"



REF.00726 Corte
Cutting

6"



REF.00727 Corte
Cutting

6,5"



Tijera INOXIDABLE

INOX Scissors

u.m.vta: 1  30

REF.00724

Esculpir
Thinning

5,5"



REF.00728

Entresacar
Thinning

5,5"



Tijera ELEGANT con filo navaja, negra y mango dorado

ELEGANT black scissors with razor edge and golden handle

u.m.vta: 1  12

REF.04499

Corte
Cutting

5,5"



REF.04500

Esculpir
Thinning

5,5"



Tijera BLACK con filo navaja, negra mate

BLACK matte scissors with razor edge

u.m.vta: 1  12

REF.04501

Corte
Cutting

5,5"



REF.04502

Esculpir
Thinning

5,5"



Tijera profesional mango aleación hoja satinada DARK GARDEN
DARK GARDEN professional scissors with alloy handle and satin blade

u.m.vta: 1  12

REF.03677 Esculpir
 Thinning



5,5"



Tijera profesional mango plástico
Professional scissors plastic handle



Microdentado
 Micro-serrated

u.m.vta: 1  12 

REF. 01977 Corte
 Cutting

6"



REF. 01978 Esculpir. 30 dientes
 Thinning. 30 teeth

6"



u.m.vta: 1  12

REF.00722 Corte
 Cutting

5,5"



REF.00723 Corte
 Cutting

6"



Tijeras ESPECIAL ACADEMIA mango plástico
SPECIAL ACADEMY scissors plastic handle



Microdentado
 Micro-serrated

u.m.vta: 1 12

REF.02807

Corte
 Cutting

5"



REF.02808

Corte
 Cutting

5,5"



REF.02809

Esculpir - 22 dientes
 Thinning - 22 teeth

6"



Tijeras INICIACIÓN
INITIATION scissors

u.m.vta: 1 12

REF.04359

Corte
 Cutting

6,5"





REF.04361

Esculpir
 Thinning

6,5"



Estuches 2 tijeras corte/esculpir
Cases 2 cutting/thinning



u.m.vta: 1  10 

CORVUS

REF.06821

6"



u.m.vta: 1  10 

SCULPTOR

REF.06825

6"



Estuche FLASH 2 tijeras corte/esculpir
FLASH Case 2 cutting/thinning

u.m.vta: 1  12

REF.07107

5,5"



Estuche polipiel Leatherette case

u.m.vta: 1  12

REF.03267

Estuche simil piel con:

- Tijera corte filo navaja
- Tijera esculpir
- Navaja de hojas cambiables 00698
- Peine profesional 00115

Imitation leather case with:

- Cutting scissors razor edge
- Thinning scissors
- Razor with interchangeable blades 00698
- Professional comb 00115

5,5"



kit corte estudiantes Cutting kit for students

u.m.vta: 1  50

REF.04901

Estuche con:

- 1 tijera corte
- 1 tijera esculpir
- 1 navaja metálica
- Hoja navaja

Case with:

- 1 cutting scissors
- 1 thinning scissors
- 1 metallic razor
- Razor blade

5,5"



Estuches 2 tijeras corte/esculpir
Cases 2 cutting/thinning scissors



Microdentado
 Micro-serrated

u.m.vta: 1  12

REF.03682

Tijeras brillantes
 Bright scissors



Estuches porta - tijeras para 20 unidades (vacío)
Scissors holder case for 20 units (empty)

u.m.vta: 1  1

REF.04634



Contenedor para tijeras Scissors container

u.m.vta: 1  12

REF.04740



Expositor tijeras Scissors display

u.m.vta: 1  20

- Metraquilato
- Methacrylate

REF.04074



Corta-cabellos Hair cutter

u.m.vta: 25  300

REF.00961



Una hoja
One blade

REF.00962

Dos hojas
Two blades



Caja 100 navajas desechables Pollié Box 100 Pollié disposable razors

u.m.vta: 1  7 

REF.02480

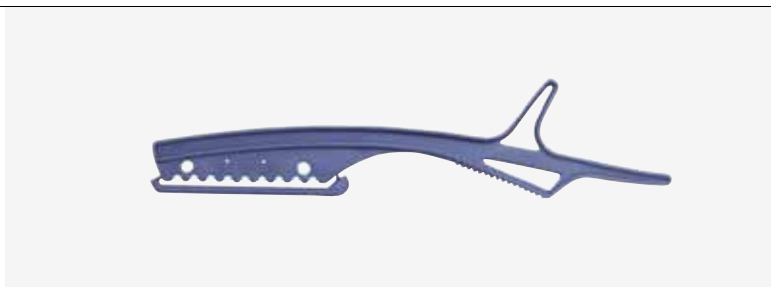

Con protector
With protector



10 Cajas de 10 cuchillas profesionales eurostil styling blades

10 Boxes of 10 eurostil professional styling blades

Con baño de teflón
With Teflon coating

u.m.vta: 1  20 

REF.07123



SCAN
ME!



Recambio para las navajas:
01498 -04073- 04075

Replacement for:
01498 -04073- 04075

La hoja está hecha de de acero inoxidable de alta calidad, con un baño de platino, que hace que la cuchilla dure más. También lleva un baño también de teflón que la hace más suave al afeitado y da una sensación más confortable en el afeitado. Van en caja de plástico que protege la cuchilla.

The blade is made of high-quality stainless-steel in platinum. It has a bath of teflon to make it last longer, give it a smoother shave and a more comfortable feeling when shaving. They come in a plastic box that protects the blade.

Navajas Razors

u.m.vta: 1  100

REF.02535/54

Navaja metálica color
plata
Silver metallic razor



u.m.vta: 1  12

REF.04073

Metálica azul
Con protector
Metallic blue
With protector



REF.04075

Mango plástico
Con protector
Plastic handle
With protector



REF.01498

Metálica color plata
Metallic silver colour



Navajas FEATHER
FEATHER razors



u.m.vta: 1 6

REF.04386

REF.04387



Caja de 10 cuchillas STYLING RAZORS · Box 10 STYLING RAZORS blades

u.m.vta: 1 5

REF.07159



u.m.vta: 1 5

REF.04388



u.m.vta: 1 5

REF.04389



Recambio para las navajas: 04386 - 04387
Replacement for: 04386 - 04387

Navaja FEATHER NAPE RAZOR
FEATHER NAPE RAZOR Razor

u.m.vta: 1 6

REF.04394



Caja de 10 cuchillas NAPE RAZOR
Box 10 NAPE RAZOR blades

u.m.vta: 1 10

REF.04395



Dispensador 20 cuchillas
20 blades dispenser

Professional PB-20

u.m.vta: 1 10

REF.04391



11

Extensiones adhesivas y cortinas Adhesive extensions & wefts

*Cortinas, extensiones, clips,
anillas, adhesivo, disolvente...*

Hair weft, extensions, clips, adhesive, solvent...



Cortinas de cabello natural remy Natural remy Hair wefts

u.m.vta: 1  10Negro
Black

N°1

REF.03354

Rojizo
Reddish

N°30M

REF. 03363

Castaño cobrizo
Cooper Brown

N°10

REF.03357

- Peso cortina 98-100 g aproximadamente.
- Weight 98-100 g aprox.



Cortinas de cabello natural remy con clip Natural Remy hair weft with clip

u.m.vta: 1  6Rojizo
Reddish

N°30M

REF.03650

Castaño rojizo
Reddish brown

N°30

REF.03651

- Cortina de 15 cm de ancho con 3 clips y 50 cm de largo
- Cabello remy
- Cada clip es de 2,8 mm
- Peso: 20 g aproximadamente (con los clips)

- 15 cm wide and 50 cm long curtain with 3 clips
- Remy hair
- Every clip is 2.8 mm
- Weight: 20 g approx (with clips)



Bote de anillas de aluminio grabado
Engraved aluminium rings pot

100 unidades para extensiones
 100 units for extensions

u.m.vta: 1  12

Negro
Black

Nº1

REF.02911

Castaño oscuro
Dark brown

Nº3

REF.02912

Castaño medio
Medium brown

Nº5

REF.02913

Rubio oscuro
Dark blonde

Nº8

REF.02914

Rubio platino
Platinum blonde

Nº13

REF.02915

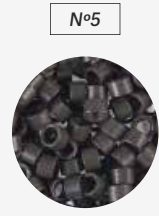
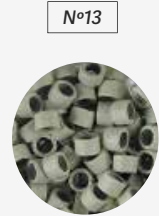
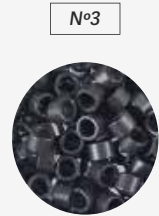
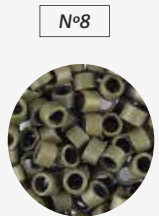

Bote de anillas de aluminio grabado
Engraved aluminium rings pot

1000 unidades para extensiones
 1000 units for extensions

u.m.vta: 1  120

Negro
Black

Nº1

REF.02867

Castaño oscuro
Dark brown

Nº3

REF.02868

Castaño medio
Medium brown

Nº5

REF.02869

Rubio oscuro
Dark blonde

Nº8

REF.02870

Rubio platino
Platinum blonde

Nº13

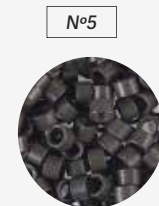
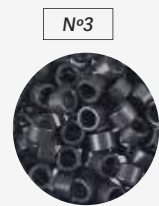
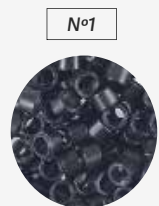

REF.02871



68 g

Bolsas de clips para extensiones grandes 3,2 cm

Bags clips large extensions 3,2 cm

u.m.vta: 1  20	u.m.vta: 12  120	u.m.vta: 1  20	u.m.vta: 12  120
50 u	4 u	50 u	4 u
REF.02924/50	REF.03269/50	REF.02924	REF.03269







Negro
Black

3,2 cm



Marrón
Brown

3,2 cm

u.m.vta: 1  20	u.m.vta: 12  120	u.m.vta: 1  20	u.m.vta: 12  120
50 u	4 u	50 u	4 u
REF.02924/54	REF.03269/54	REF.02924/66	REF.03269/66



Plata
Silver

3,2 cm







Rubio
Blonde

3,2 cm

Bolsas clips extensiones 2,8 cm

Bags clips extensions 2,8 cm

u.m.vta: 1  20	u.m.vta: 12  12	u.m.vta: 1  20	u.m.vta: 12  12
50 u	4 u	50 u	4 u
REF.03306/50	REF.03270/50	REF.03306	REF.03270







Negro
Black

2,8 cm



Marrón
Brown

2,8 cm

u.m.vta: 1  20	u.m.vta: 12  12	u.m.vta: 1  20	u.m.vta: 12  12
50 u	4 u	50 u	4 u
REF.03306/54	REF.03270/54	REF.03306/66	REF.03270/66

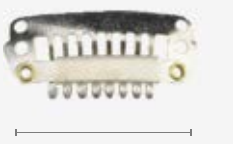

Plata
Silver

2,8 cm





Rubio
Blonde

2,8 cm

Bolsa de clips para extensiones 2,3cm

Bag clips extensions 2,3cm

u.m.vta: 1  20	u.m.vta: 12  12		u.m.vta: 1  20	u.m.vta: 12  12	
50 u	4 u	Negro Black	50 u	4 u	Marrón Brown
REF.03307/50	REF.03271/50	2,3 cm	REF.03307	REF.03271	2,3 cm

u.m.vta: 1  20	u.m.vta: 12  12		u.m.vta: 1  20	u.m.vta: 12  12	
50 u	4 u	Plata Silver	50 u	4 u	Rubio Blonde
REF.03307/54	REF.03271/54	2,3 cm	REF.03307/66	REF.03271/66	2,3 cm

Adhesivo para fijar cortinas de cabello

Adhesive to fix hair wefts

u.m.vta: 1  12 		u.m.vta: 1  12 	
50 ml	A base de látex natural Color del adhesivo oscuro	50 ml	A base de látex natural Color del adhesivo blanco
REF.03176/50	Made from natural latex Dark colour	REF.03176/58	Made from natural late. Withe colour

Disolvente para extensiones de queratina

Solvent keratine extensions

u.m.vta: 1  20 	
150 ml	
REF.03164	

Disolvente adhesivo cortinas

Solvent glue for hair wefts

u.m.vta: 1  20 	
150 ml	
REF.03177	

Bolsa de 12 discos para extensiones
Bag 12 protectors hair extensions

u.m.vta: 1  60

12 u

REF.02582



Bolsa de ganchos para anillas
Bag hook for rings



u.m.vta: 1  5

12 u

REF.02873



Alicate para extensiones
Nipper for hair extensions

u.m.vta: 1  12 

REF.07599



REF.07601



u.m.vta: 1  60

REF.02872

Mango bicolor
 Bicoloured handle



Muestrario color extensiones
Sample colour extensions

u.m.vta: 1  20

REF.03378



Kit extensiones
Extensions kit

u.m.vta: 1  12

REF.04208





12



Varios Various

*Toallas, maletas,
pulverizadores, algodón...*

*Towels, suitcases,
sprayers, cotton...*

1 Kg de algodón en rollos

1 Kg of cotton in rolls



u.m.vta: 1	 12	
------------	--	---

REF. 00964

9 cortes de 3,5 cm
(puntas incluidas)
9 cuts of 3.5 cm (tips
included)



Anónimo
Anonymous

REF. 00964/00

u.m.vta: 1	 12	
------------	--	---

REF. 04290

Ancho
4 cortes de 8 cm
(puntas incluidas)
Width
4 cuts of 8cm (tips
included)

u.m.vta: 1	 10	
------------	--	---

REF. 04288

Plegado
9 cortes de 3,5 cm
(puntas incluidas)
Folded
9 cuts of 3.5 cm
(tips included)



Bolsa de peluquería negra Black hairdressing handbag

u.m.vta: 1  6



REF.02517

u.m.vta: 1  10

REF.02596



Bolsa grande de peluquería eurostil school Large eurostil school hair styler's bag



u.m.vta: 1  25 

Transformable en mochila
It can be converted into a backpack

REF. 07473



Bolsa de porta-útiles negro Black handbag for tools

u.m.vta: 1  6 

REF. 02516



Bolsa - mochila para academia Backpack bag for academy

u.m.vta: 1  15

REF. 07018



Cómoda maleta negra de tela con colgador y con tiras para poder colgar como mochila. Posee un agarre para llevar como maleta de mano y también una cinta para colgar al hombro. Incluye 2 compartimentos y un tarjetero

Comfortable black fabric case with hanger and straps to wear as a backpack. It has a grip to carry as a handbag and also a shoulder strap. It includes two compartments and a cardholder

Maletas aluminio Aluminium suitcases

Todas las maletas se venden vacías
All the cases sold empty

u.m.vta: 1  4

Para útiles, interior 6
compartimentos y 4
bandejas
For tools, 6
compartments and
4 trays

REF.03599



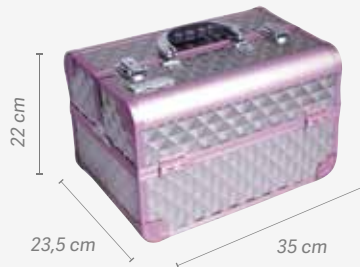

REF.03598



u.m.vta: 1  1

REF.02318



u.m.vta: 1  1

REF.04307



Maletas de aluminio
Aluminium suitcase

Todas las maletas se venden vacías
All the cases sold empty

u.m.vta: 1  4

REF.01492



REF.02317



REF.04306



Porta útiles
Tools

REF.01497



Maletas de aluminio
Aluminium suitcase

Todas las maletas se venden vacías
All the cases sold empty

u.m.vta: 1  4

REF. 02319



Maleta PVC negra
Black PVC suitcase

Todas las maletas se venden vacías
All the cases sold empty

u.m.vta: 1  4

REF.02925



Maleta profesional gris melamina (vacía)
Melamine grey professional case (empty)

u.m.vta: 1  4

REF.02593



Todas las maletas se venden vacías
All the cases sold empty

Maleta trolley
Trolley suitcase

u.m.vta: 1  4

●
REF.02523/50

u.m.vta: 1  1

●
REF.03814/50

u.m.vta: 1  1

●
REF.02929/50

REF.02929



Maleta trolley de polipiel para peluquería
Trolley suitcase leatherette hairdressing

Todas las maletas se venden vacías
 All the cases sold empty

u.m.vta: 1  1

REF.04308



Maleta trolley "COCODRILO" de polipiel para peluquería
Trolley suitcase leatherette hairdressing "COCODRILO"

Todas las maletas se venden vacías
 All the cases sold empty

u.m.vta: 1  1

REF.06136

- Consta de: 3 compartimentos amplios con 2 bandejas cada uno en la parte superior. La bandeja dispone de unos compartimentos para poder poner utensilios.
- Con ruedas extraíbles permite trasladarlo de manera más cómoda y fácil, según se necesite.

- 3 large compartments with 2 trays at the top with holes for utensils.
- 4 wheels for easy moving
- With removable wheels



Maleta de 4 cuerpos 4 body suitcase

Todas las maletas se venden vacías
All the cases sold empty

u.m.vta: 1  1



REF.03178



REF.03178/80



REF.03178/68



- Maleta de 3 cuerpos. Los 2 primeros en la base inferior tienen 4 patas y el cuarto tiene 5 ruedas
- Interior recubierto de espuma negra
- Asa regulable en altura según necesidad de cuerpos
- 1º y 2º cuerpo: aprox. 24,5 x 21,5 x 9 cm de altura, incluye 2 separadores laterales con guías para adaptar el espacio según necesidades.
- 3º cuerpo: aprox. 24,5 x 21,5 x 35 cm de altura, totalmente diáfano
- 4º cuerpo: aprox. 24,5 x 21,5 x 18 cm de altura, totalmente diáfano
- 3 body suitcase. The first 2 in the lower base have 4 legs and the fourth has 5 wheels
- Covered black foam core
- Adjustable handle based on the needs of the bodies
- 1st and 2nd bodies: approx. 24.5 x 21.5 x 9 cm tall, includes 2 side separators with rails that allow you to adjust the space to your needs
- 3rd body: approx. 24.5 x 21.5 x 35 cm tall, entirely open
- 4rd body: approx. 24.5 x 21.5 x 18 cm tall, entirely open

Bolsa de peluquería con ruedas Hairdressing bag with wheels

Todas las maletas se venden vacías
All the cases sold empty

u.m.vta: 1  1

Con estructura metálica que permite usar la maleta como asiento

With metal structure that allows to use the suitcase as a seat



REF.04402/50



REF.04402/80

Neceser (vacío) incluido

Vanity case (empty) included in



Maleta doble de nylon con ruedas Nylon double suitcase with wheels

u.m.vta: 1  1

REF.04943

La maleta superior se puede convertir en maleta de mano, que viene con una tira para colgar del hombro. Tiene dos bandejas interiores las cuales pueden ser desplazadas hacia los laterales, el interior es amplio y la parte inferior es extraíble y está plastificada para facilitar la limpieza de la maleta. También en la parte trasera tiene un bolsillo exterior. La maleta inferior con ruedas tiene la parte interior plastificada, es extraíble para facilitar la limpieza y viene con una manta porta pinceles que está pegada mediante un velcro. Esta manta se puede intercambiar entre la maleta superior e inferior. Tiene 8 cajones para guardar y separar pequeños productos. Tiene un bolsillo en cada lateral. Cada columna integra 4 cajones que van unidos en una sola pieza, son extraíbles.



The upper case can be turned into a hand luggage, it has a strip to hold it in the shoulder. It has two interior trays that can be moved to both sides. The inside part is wide and the bottom is laminate and removable so the cleaning process its easier. In addition, there is a pocket in the back. The case below has wheels and the interior part is laminated and removable for easy cleaning. It includes a bag to keep make up brushes stucked with velcro. This bag can be exchanged between the top and the bottom suitcase. It has 8 drawers to keep and separate small products. It has a pocket on each side. Each column integrates 4 drawers that are joined in one piece and are removable.

Maleta trolley 2 cuerpos 2 section trolley suitcase

Todas las maletas se venden vacías
All the cases sold empty

u.m.vta: 1  1

REF.04939/50

REF.04939

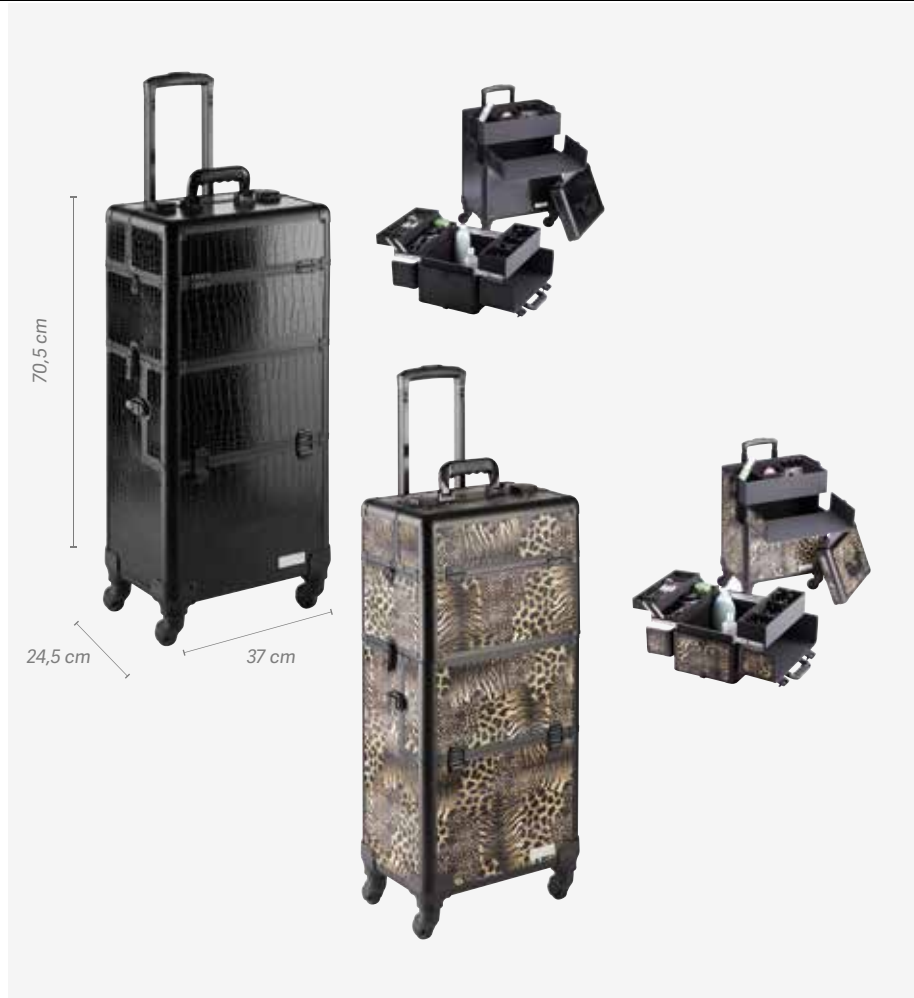

La maleta trolley de Pollié, está creada en base a una estructura de 2 cuerpos modificables, pensado para facilitar el almacenaje al profesional de sus utensilios de peluquería, maquillaje o cosmética.

La parte superior de la maleta consta de tres bandejas extraíbles. Cada una de ellas está dividida en tres compartimentos.,

A su vez, en una de ellas, encontrarás doce espacios circulares pensados para almacenar las lacas de uñas y así evitar su desprendimiento, facilitando su transporte con total seguridad. Asimismo, el interior del cuerpo superior puede ser modificado según sus necesidades, variando la estructura de los compartimentos. Para finalizar, su función 2 en 1 les permitirá disponer de una maleta de mano, o bien se lo prefieren colgársela al hombro, gracias a su tira de nylon.

La parte inferior de la maleta, tiene una bandeja extraíble con opción de 4 compartimentos también modificables gracias a los separadores. el cuerpo inferior, con gran capacidad en su interior, les dará la opción de un transporte más ligero, ya que se puede convertir en una maleta más pequeña, con tapa y espejo incorporado en ésta. Las ruedas son intercambiables mediante la pestaña de enganche. El trolley dispone de dos bobinas y dos llaves de recambio.

The trolley suitcase of Pollié, is created based on a structure of 2 modifiable bodies, designed to facilitate the professional storage of your hairdressing, makeup or cosmetic utensils.

The top of the suitcase consists of three removable trays. Each of them is divided into three compartments., So, in one of them, you will find twelve circular spaces designed to store nail lacquers and thus prevent their detachment, facilitating their transport with total security. Also, the interior of the upper body can be modified according to your needs, varying the structure of the compartments. Finally, its 2-in-1 function will allow them to have a handbag, or they prefer to hang it on the man, thanks to its nylon strip.

The lower part of the suitcase has a removable tray with the option of 4 compartments that can also be modified thanks to the spacers. The lower body, with large capacity inside, will give them the option of lighter transport, since it can be converted into a smaller suitcase, with a lid and mirror incorporated in it. The wheels are interchangeable using the hitch tab. The trolley has two coils and two spare keys.



Estuche porta útiles negro
Black purse for tools

Todos los porta útiles se venden vacíos
 All the purses for tools sold empty

u.m.vta: 1		8	
------------	---	---	---



REF. 01238



u.m.vta: 1		6	
------------	---	---	---



REF. 01236



u.m.vta: 1		8	
------------	--	---	--

REF. 01237





u.m.vta: 1		5	
------------	---	---	---

REF. 02515





Cinturón porta-útiles
Belt for tools

Todos los porta útiles se venden vacíos
All the purses for tools sold empty

u.m.vta: 1		5	
------------	---	---	---

REF. 02513



u.m.vta: 1		10	
------------	---	----	---

REF. 02514



u.m.vta: 1		48
------------	---	----

Con 5 bolsillos
combinables
With 5 pockets

REF.03622





u.m.vta: 1		48
------------	---	----

REF.04310



Caja 50 unidades protector facial FACEPRO
Box of 50 units FACEPRO face protector

Artículos de venta exclusiva EN ESPAÑA, PORTUGAL Y ANDORRA
 This product are sold exclusively IN SPAIN, PORTUGAL AND ANDORRA

u.m.vta: 1  10 

Orgánico
Organic
 REF. 04480



NO Orgánico
NO Organic
 REF. 04223



Face pro protege el rostro del pelo cortado, de la laca, aire caliente del secador, tintes...
Facepro protects your face from cut hair, hairspray, and hot air from the hair dryer, hair dyes...

Caja organizadora (vacía)
Organiser box (empty)

Vacía
 Empty

u.m.vta: 1  24

u.m.vta: 1  12

●
 REF.04722

●
 REF.04309

Imantada
 With magnet



Portaútiles silicona
silicone purse tools

u.m.vta: 1  48

u.m.vta: 1  6

●
 REF.04404/68

Con ventosas
 With suction cups

●
 REF.04370



Tarjetero aluminio
Aluminium card case

u.m.vta: 1  400

REF.02470





Colgador bolso
Bag hanger

u.m.vta: 12  250

REF.03304





Protector facial
Protector for face

u.m.vta: 20  20 

REF.01233



Espejos
Mirrors

u.m.vta: 1  12 

REF.00287





Espejos
Mirrors

u.m.vta: 1  12 

REF.00286



u.m.vta: 1  6 

REF.02538/54





u.m.vta: 1  12

REF.03626



Porta pelucas
Wig holder



u.m.vta: 1  10

u.m.vta: 1  20 

REF. 03489

Porexpan
Porexpan

REF. 04367

u.m.vta: 1  60 

Viaje
Travel





REF.00982



REF.00982/50



Spray Mini
Mini Spray



u.m.vta: 1  234 

30 ml

REF.07481



Spray Barber
Barber Spray

u.m.vta: 1  20 

30 ml



REF.07001



- Botella transparente con pulverizador negro
- Material: plástico
- Peso 45 gramos

- Transparent bottle + black trigger
- Plastic
- Weight 45g

Pulverizador tijera & peine Scissor and comb sprayer



u.m.vta: 1  12 

300 ml

REF.07482



Pulverizador transparente colores Transparent colours sprayer

u.m.vta: 12  84 

300 ml

330 ml



REF.01372

REF.00959

Redondo
Round

300 ml

300 ml





REF.01484

REF.01663



Pulverizador 360° Continuous disinfectant sprayer

u.m.vta: 1  12 



300 ml

REF.04731

- Spray continuo: con una sola presión pulveriza el agua de manera fina y uniforme con la misma presión desde el inicio hasta la última gota.
- 360°: se puede usar desde todos los ángulos, incluso boca abajo. Pulverización fina, tipo niebla que distribuye el agua de manera uniforme sobre todo el cabello.
- Capacidad: 300 ml rellenable.
- Volúmen fijo de presión: 1,25 cc continuo.
- Evita la fatiga de la mano en comparación con los sprays estándar. Sin gases contaminantes.
- Continuous spray: with a single pump, it sprays the water finely and evenly with the same pressure from the start to the last drop.
- 360°: can be used from all angles, even upside down. Fine, mist-like spray that distributes water evenly throughout the hair.
- Capacity: 300 ml refillable.
- Fixed pressure volume: 1.25 cc continuous.
- Avoids hand fatigue compared to standard sprays. No polluting gases.



Pulverizador aluminio Aluminium sprayer

u.m.vta: 1  35 

Interior lacado
Lacquered inside

Neutro
Unprinted

280 ml

280 ml

REF.01384

REF.01384/02



Expositor 30 pulverizadores aluminio Display 30 aluminium sprayers

u.m.vta: 1  1

Eurostil
Eurostil

Neutro
Unprinted

280 ml

280 ml

REF.01465

REF.01465/02



Pulverizador plástico Plastic sprayer

u.m.vta: 1  180 

Con colgador
With hanger

130 ml

REF.03401



u.m.vta: 20  80 

STIL. Transparente
Transparent. STIL

260 ml



REF.02683

u.m.vta: 1  24 

Negro japonés
Black japanese



300 ml

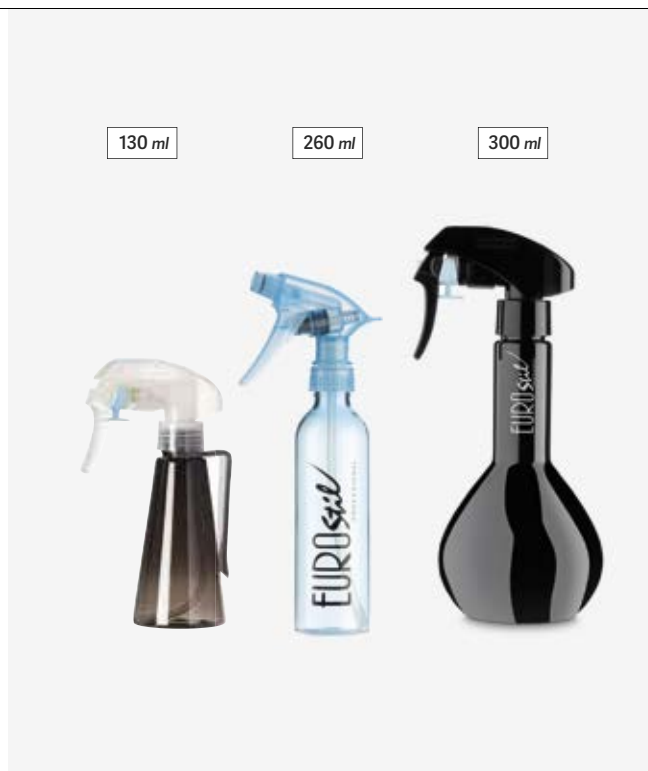

REF.04377



Toalla 100% algodón
100% cotton towel

u.m.vta: 12  48 

 
REF. 02947/50 **REF. 02947/58**



 
REF. 02901/50 **REF. 02901/58**



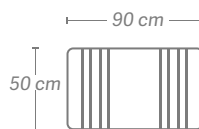
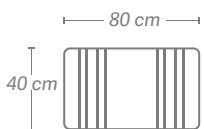

Resistente lejía
Resistant bleach

REF. 04953/50





REF. 06829/50



Gel hidro-alcohólico con Aloe Vera
Sanitising gel with Aloe Vera

u.m.vta: 1		40		u.m.vta: 1		20	
100 ml				500 ml			
REF.07245				REF.07235			



u.m.vta: 1		12		u.m.vta: 1		2	
1 L				5 L			
REF.07267				REF.07268			

Solución hidro-alcohólica
Sanitising solution

u.m.vta: 1		23
500 ml		
REF.07175		



u.m.vta: 1		7	
1 L			
REF.07259			

Bomba dosificadora gel 1l/500 ml
Gel dosing pump 1l / 500 ml



u.m.vta: 1		40
REF.RE07267		



Ideal para mezclar con agua y poner en pulverizador para limpiar y desinfectar superficies.

Ideal for mixing with water and spraying to clean and disinfect surfaces.

Gel hidro-alcohólico Sanitising gel



u.m.vta: 1  22 

500 ml

REF.07215



Alcohol 96° Alcohol 96°

u.m.vta: 1  12 

1 L

REF.07217



Higienizante de manos en spray Spray hand sanitiser

u.m.vta: 1  12 

400ml

REF.07231



Caja expositora 120 sachets con toallita higienizante 120 SACHETS DISPLAY BOX WITH HYGIENE WIPE

u.m.vta: 1  6

REF.07236



Para higienizar las manos sin necesidad de agua y jabón. Formulado para mantener las manos limpias en cualquier momento protegiéndolas de factores externos. Alto contenido en Glicerina que actúa como hidratante para la piel. USO EXCLUSIVO SOBRE PIEL SANA.

For hand hygiene without the need for soap and water. Formulated to keep hands clean by protecting them from external factors. High glycerine content, which acts as a moisturiser for the skin. EXCLUSIVE USE ON HEALTHY SKIN.

Limpieza sin agua. Para una piel sana y limpia en cualquier parte

Resistant bleach Cleaning without water. For healthy, clean skin everywhere and anywhere.

Artículos de venta exclusiva EN ESPAÑA
 Those product are sold exclusively IN SPAIN



Antiséptico daromix GH
Daromix GH antiseptic

u.m.vta: 1  12

1 L

REF.06200

Desinfectante Limoseptol
Limoseptol disinfectant

u.m.vta: 1  20 

u.m.vta: 1  20

50 ml

1 L

REF. 06151

REF.06150



- N° Registro AEMPS: 905-DE5
- Antiséptico hidroalcohólico para desinfección higiénica de manos por fricción
- Eficacia garantizada científicamente
- Amplio espectro biocida a partir de 30 seg
- Fórmula hipoadérgica
- Preserva la hidratación de la piel
- No irritante cutáneo
- Seca rápidamente
- Eficaz como: bactericida, levuricida, virucida, microbactericida

- Registration Number AEMPS: 905-DE5
- Water alcohol antiseptic for hygienic friction disinfection
- Scientific efficiency guaranteed
- Wide biocide range from 30 sec
- Hypoallergenic formula
- Preserves skin hydration
- No skin irritation
- Quick drying
- Effective as: bactericide, levuricide, virucidal and microbactericide

- Dosis: 100 ml en 10 l de agua
- Tiempo: 15 min
- N° Registro AEMPS: 47-DE5
- Producto de gran alto nivel desarrollado exclusivamente para la higiene, limpieza y desinfección, de utensilios profesionales de salones de belleza
- Acción detergente - Amplio espectro
- Biodegradable - Sin fosfatos y SIN FORMOL
- Eficacia germicida y DESINFECTANTE frente a: bacterias, levaduras y hongos

- Dosage: 100 ml in 10 l of water
- Time: 15 min
- Registration Number AEMPS: 47-DE5
- High level product developed exclusively for the hygiene, cleaning and disinfection, for professional utensils of salons of beauty
- Detergent action - Wide spectrum
- Biodegradable - No phosphates/formol
- Disinfectant and germicide efficiency against bacteria, yeast and fungi

Alfombra desinfectante de calzado

Shoe disinfectant mat

u.m.vta: 1  12

REF.07234

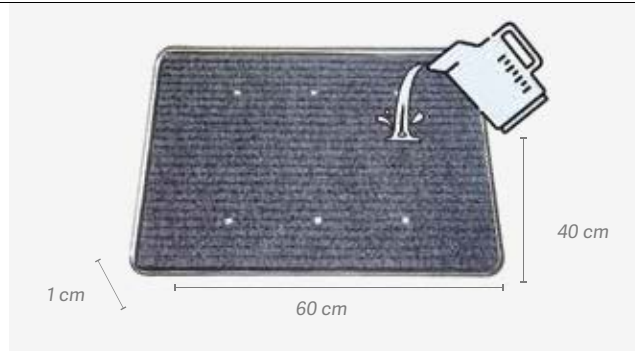

Alfombrilla extraplana de solo 1cm de alto para evitar tropiezos fabricada en polipropileno sobre una base de caucho y contenedor de aluminio ionizado. Medidas: 60 cm de ancho x 40 cm de largo x 1cm de alto/grosor.



Extra flat mat. Only 1cm high to avoid tripping. Made of polypropylene on a rubber base and ionised aluminium container. Measurements: 60 cm wide x 40 cm deep x 1 cm high/thick

Modo de uso: colocar la alfombra sobre una superficie plana y nivelada aplicar en la bandeja unos 700ml aproximadamente de líquido desinfectante. Se aconseja colocar un felpudo después de la bandeja para secar el calzado del cliente.

Instructions for use: Place the carpet on a flat, level surface and apply approximately 700 ml of disinfectant liquid to the tray. Place a mat after the tray to dry the customer's shoes.

Gafa protectora antivaho

Anti-fog protective goggles

u.m.vta: 1  10 

REF.07256



- Protección para prevenir infecciones: protegen eficazmente de las salpicaduras, grava, etc.
- Lugar de uso: cualquier lugar donde se requiere protección para los ojos.
- Diseño innovador cómodo. Se ajustan perfectamente a cualquier forma y tamaño de cabeza. Se pueden utilizar al mismo tiempo que sus gafas graduadas.
- Certificado CE
- Material: plástico

- Protection to prevent infection: They effectively protect from splashing, gravel, etc.
- Place of use: any place where eye protection is required.
- Innovative and comfortable design. They fit any shape and size head perfectly.
- They can be used with your prescription glasses.
- CE-certified
- Material: plastic

Bolsa 100 peucos cubrezapatos

Bag 100 shoe covers

u.m.vta: 1  50

REF.07211



Plástico. Un solo uso
Plastic. Disposable

Dispensador gel automático de pared con bandeja

Gel mounted automatic gel dispenser with tray

u.m.vta: 1  12

1 L

REF.07271



Dispensador gel automático de sobremesa

Desktop automatic gel dispenser

u.m.vta: 1  12

1 L

REF.07272



Dispensador gel automático de pared con pie

Floor standing automatic gel dispenser

u.m.vta: 1  12

1 L

REF.07273



Dispensador gel manual de pared

Manual wall dispenser

u.m.vta: 1  12

700 ml

REF.07274



- Material ABS
- Tipo de bomba: goteo de gel
- Fuente alimentación 4 baterías /LR14 tamaño C)
- Distancia de detección: 6-10 cms.
- Salida: 0,8-1 ml ajustable

- Material: ABS
- Pump type: gel drip
- Power supply: 4 Batteries (LR14 size C)
- Sensing distance: 6-10 cms.
- Outflow: 0,8-1 ml adjustable



Escobas de goma Rubber brooms

u.m.vta: 4  16

Con lengüeta
With thead

REF.01223



u.m.vta: 5  20 

REF. 01285/50



u.m.vta: 5  20

Rosca española e italiana
Spanish and Italian thread

REF.02420



- De fácil limpieza y de larga duración, la eficacia del diseño de sus púas logra arrastrar el polvo sin levantarlo, por lo que es ideal para personas alérgicas ya que favorecen a un ambiente limpio
- Easy to clean and long-lasting, the effectiveness of the design of its spikes manages to drag the dust without lifting it, making it ideal for allergy sufferers as they favor a clean environment

Mango para escoba Broom handle

Rosca española e italiana
Spanish and Italian thread

u.m.vta: 12  12

REF.01131

- De fácil limpieza y larga durabilidad
- Soporte de plástico
- Ideal para todo tipo de suelos, en especial el parquet

- Easy cleaning and long durability
- Plastic support
- Ideal for all types of floors, especially wood floor



u.m.vta: 10  10

REF.01365

- Telescópico extra
- Extra telescopic



