

**Pollié**   
*Pensando en el profesional*

 **TASSEL**  
SKIN COSMETICS

**Especial estética**  
**Special Aesthetic**

**Sin precio / Without prices**

**ANDREA**  
Pestañas

**BEAUTENE**

**maniquick**  
Quality Treatment & Innovation

**MEDISANA**

**promed**



## 01 Línea cuidado facial Facial care line 4

Limpieza y preparación de la piel ..... 5 <i>Cleansing and preparation of the skin</i>	5
Cremas y tratamientos y aceites esenciales ..... 8 <i>Creams and treatments and essential oils</i>	8
Vapores y accesorios · <i>Steamers and accessories</i> ..... 23	23

## 02 Línea cuidado corporal Body care line 26

Cremas y tratamientos y aceites bases ..... 27 <i>Creams and treatments and base oils</i>	27
Accesorios · <i>Accessories</i> ..... 35	35

## 03 Depilación Depilation 36

Cera formato Kg · <i>Wax format Kg</i> ..... 37	37
Accesorios cera · <i>Accessories wax</i> ..... 48	48
Cera formato roll-on · <i>Wax roll-on format</i> ..... 50	50
Accesorios cera roll-on · <i>Accessories roll-on wax</i> ..... 54	54
Accesorios depilación · <i>Hair removal accessories</i> ..... 57	57
Pinzas depilar · <i>Hair removal tweezers</i> ..... 66	66

## 04 Manicura y pedicura Manicure and pedicure 72

Esmalte Pollié · <i>Pollié nail polish</i> ..... 73	73
Esmalte semipermanente P-Lack ..... 80 <i>Semi-permanent nail polish P-LACK</i>	80
Acrylic gel · <i>Acrylic gel</i> ..... 82	82
Quitaesmaltes y crema de manos ..... 84 <i>Nail polish remover and hand cream</i>	84
Pinceles gel y acrílico · <i>Gel and acrylic brushes</i> ..... 87	87
Accesorios NAIL ART · <i>NAIL ART accessories</i> ..... 89	89
Lámparas · <i>Lamps</i> ..... 99	99
Parafina · <i>Paraffin</i> ..... 105	105
Tornos · <i>Nail drills</i> ..... 107	107
Lupas · <i>Magnifying lamps</i> ..... 116	116
Limas y bloques pulir · <i>Nail files and nail polishing buffers</i> ..... 118	118
Esterilizadores · <i>Sterilizers</i> ..... 135	135
Alicates cortacutículas · <i>Cuticle nippers</i> ..... 137	137
Alicates cortaúñas · <i>Nail clippers</i> ..... 142	142
Empujadores · <i>Cuticle pushers</i> ..... 146	146
Accesorios manicura · <i>Manicure accessories</i> ..... 147	147
Tijeras pieles y uñas · <i>Scissors cuticles and scissors nails</i> ..... 148	148
Baja pieles ..... 150 <i>Orange sticks</i>	150
Específicos pedicura · <i>Specific pedicure</i> ..... 151	151

## 05 Maquillaje Make-up 162

Lápices, eyeliners y máscara pestañas ..... 163 <i>Pencils, eyeliners and eyelashes mascara</i>	163
Espojas desmaquillar · <i>Make-up remover sponges</i> ..... 168	168
Espojas maquillaje · <i>Make-up sponges</i> ..... 169	169
Brochas / Pinceles de maquillaje ..... 173 <i>Makeup brushes/pencils</i>	173

## 06 Pestañas Eyelashes 188

Pestañas Pollié · <i>Pollié eyelashes</i> ..... 189	189
Pestañas Andrea · <i>Andrea eyelashes</i> ..... 195	195
Kits de pestañas, mechones y pelo a pelo ..... 197 <i>Eye-lashes kits, eyelashes locks and one by one hair</i>	197
Expositores, pegamento pestañas y accesorios ..... 199 <i>Displays, glue eyelashes and accessories</i>	199
Cejas · <i>Eyebrows</i> ..... 201	201

## 07 Accesorios e higiene Accessories and hygiene 202

Fundas y papel camilla ..... 203 <i>Covers and massage table paper</i>	203
Toallas y sábanas ..... 204 <i>Towels and bed sheets</i>	204
Protectores y guantes · <i>Protectors and gloves</i> ..... 207	207
Un solo uso · <i>Single use</i> ..... 211	211
Algodón · <i>Cotton</i> ..... 218	218
Espesos · <i>Mirrors</i> ..... 219	219
Mascarillas faciales · <i>Facial Masks</i> ..... 226	226
Vestimenta/Uniformes LACLA · <i>LACLA Clothing / uniforms</i> ..... 228	228
Aro luz led · <i>Led ring light</i> ..... 234	234
Maletas · <i>Suitcases</i> ..... 236	236
Pulverizadores · <i>Sprayers</i> ..... 242	242
Potectores rayos UV · <i>UV protectors</i> ..... 243	243
Higiene y desinfectantes · <i>Hygienic and disinfectants</i> ..... 244	244

## 08 Mobiliario Furniture 248

Camillas · <i>Massage table</i> ..... 249	249
Mesas manicura · <i>Manicure tables</i> ..... 254	254
Carritos manicura/pedicura ..... 255 <i>Manicure/pedicure trolleys</i>	255
Taburetes, sillas y soportes ..... 258 <i>Stools, chairs and supports</i>	258
Maletines y sillas de maquillaje ..... 263 <i>Make-up cases and make-up chairs</i>	263



Los precios que figuran en este catálogo son precios recomendados, impuestos no incluidos.  
Los precios serán vigentes salvo errores tipográficos.  
Industrias Oriol 1942, S.L. se reserva el derecho a realizar modificaciones sin previo aviso.

*The prices in the catalog are intended for professionals and do not include VAT.  
Prices are up to date unless there is a typographical error.  
Industrias Oriol 1942 S.L. reserves the right to make changes without notice.*

01

## Línea de cuidado facial Facial Care line

*Limpieza y reparación de la piel, cremas  
y tratamiento, expositores, accesorios...*

*Cleansing and preparation of the skin, creams  
and treatments, displays, accessories...*





## Agua micelar vs leche limpiadora Micellar water vs cleansing milk



Para una buena limpieza facial es imprescindible una leche limpiadora que arrastre toda la suciedad y un tónico que limpie los restos a la vez que desinfeste y cierre los poros. El tónico y leche limpiadora Tassel contienen azuleno que es más cuidadoso con las pieles sensibles. También se puede utilizar el agua micelar que ahorra pasos en el proceso de la limpieza y es suave con la piel. Varias opciones para limpiar tu piel. ¡Escoge tu producto!

*For a proper facial cleansing, a good cleansing milk that can remove any impurities, followed by a tonic that cleans out the remains while disinfecting and closing pores, are indispensable. The Tassel tonic and cleansing milk contain azulene, which is milder with sensitive skins. Micellar water, which saves steps in the cleaning process and is also easy on the skin, can be used as well. Several options to clean your skin, choose your product!*

### Leche limpiadora Cleansing milk

u.m.vta: 1 12

500 ml

REF.07094



### Tónico revitalizante Revitalising tonic

u.m.vta: 1 12

500 ml

REF.07095



#### Aceite de argán y aloe vera

El uso de la leche limpiadora ayuda a eliminar las impurezas y los restos de suciedad acumulados en la piel. De esta forma, la piel se oxigena, luce más luminosa y sana. Con azuleno para pieles sensibles, no gasa. De uso diario.

#### Argan oil and aloe vera

*Using cleansing milk helps clean out impurities and dirt that accumulate on the skin. This allows the skin to breathe, providing with a brighter and healthier look. Contains azulene, ideal for sensitive skin. Daily use.*

#### Aceite de argán y aloe vera

El uso del tónico facial actúa de equilibrante tras la limpieza con la leche limpiadora. Es el paso definitivo para completarla. Aporta frescor y vitalidad a la piel. Contiene azuleno, ideal para pieles sensibles. De uso diario.

#### Argan oil and aloe vera

*The use of a facial tonic provides a balancing effect after cleaning with cleansing milk, and it is the definitive step to complete your cleansing. It provides freshness and vitality to the skin. Contains azulene, which makes it ideal for sensitive skins. Intended for daily use.*

## Exfoliante facial

### Facial scrub

u.m.vta: 1

15



100 ml

REF.06071



### Mineral natural como exfoliante

El aceite de argán y el de aloe vera poseen propiedades reestructurantes y regenerantes. El activo mineral natural posee grandes propiedades de exfoliación. Elimina y arrastra las células muertas sin dañar la piel dejándola limpia, suave, luminosa y con gran capacidad respiratoria favoreciendo la absorción de cualquier tratamiento de belleza. Puede utilizarse como exfoliante facial habitual.

### Natural mineral as an exfoliant

Argan oil and aloe vera have restructuring and regenerating properties. The mineral natural asset has great exfoliation properties. Removes and drags dead cells without damaging the skin leaving it clean, soft, luminous and with great respiratory capacity favoring the absorption of any beauty treatment. It can be used as a regular facial scrub.

## Black Mask limpieza profunda

### Black Mask deep cleaning

u.m.vta: 1

12



50 ml

REF.04580

### Máscara Peel-off:

Producto elaborado especialmente en base a una fórmula suave y eficaz, que contiene carbón vegetal activo, aloe vera, avena y glicerina vegetal. Permite limpiar profundamente las impurezas de la piel, sin ningún tipo de daño ni agresión a la misma.

### Peel-off mask:

Product made especially on the basis of a gentle and effective formula, containing active coal, aloe vera, oats and vegetable glycerin. It allows to clean deeply the impurities of the skin, without any type of damage or aggression to it.

## Agua micelar

### Micellar water

u.m.vta: 1

9



400 ml

REF.04206



### Limpia, tonifica e hidrata

Agua micelar 3 en 1. Limpia, desmaquilla y elimina impurezas de la piel sin necesidad de aclarado. Respetando el equilibrio hídrico y Ph de la piel dejándola limpia y suave. Eficaz con el maquillaje más resistente. Suave aroma a rosas.

### Cleanses, tones and hydrates

3 in 1 micellar water. Cleanses, removes make-up and impurities from the skin without rinsing. It respects the moisture and Ph balance of the skin, making it clean and soft. Effective even against the most resistant make-up. Soft scent of roses.



SCAN ME!





**TASSEL SKIN COSMETICS lanza al mercado la línea HYALURONIC**  
**TASSEL SKIN COSMETICS launches the HYALURONIC line to the market**

El ácido hialurónico es un componente estructural de la matriz extracelular de la piel que, junto con el colágeno y las fibras elásticas, forman la estructura de la dermis cutánea y es el encargado de mantener la piel hidratada. Una falta de hidratación puede producir efectos contraproducentes en nuestra dermis y epidermis, haciendo la piel más sensible a los factores que aceleran el envejecimiento.

*Hyaluronic acid is a structural component of the extracellular matrix of the skin that, together with collagen and elastic fibers, form the structure of the dermal dermis and is responsible for keeping the skin hydrated. A lack of hydration can produce counterproductive effects on our dermis and epidermis, making the skin more sensitive to factors that accelerate aging.*



**Expositor hyaluronic (de regalo)**  
**Free hyaluronic display**

u.m.vta: 1  1

**REF.07800**

Incluye 2 Cremas de ácido hialurónico ref. 06798 y + 2 sérums de ácido hialurónico ref. 06799.

*Includes 2 hyaluronic acid creams ref. 06798 and + 2 hyaluronic acid serums ref. 06799.*



## Crema hyaluronic

### Hyaluronic cream

u.m.vta: 1



24



50 ml

REF.06798



Específico para pieles deshidratadas. Por su composición, Redensifica la piel disminuyendo de forma inmediata la profundidad de las arrugas. Combate las líneas de expresión. Uso diario.

#### Propiedades:

- Altamente hidratante y humectante
- Mejora visiblemente la barrera lipídica de la piel
- Estimula la regeneración celular de la piel
- Suaviza las líneas de expresión, reduciendo la profundidad de las arrugas
- Rellena las líneas finas y las arrugas de la piel

**Aplicación:** aplicar sobre la piel limpia tanto en la zona facial, como cuello y escote con suaves masajes circulares, hasta la total absorción. Se puede aplicar día y noche dependiendo de la necesidad de la piel.

*Specific for dehydrated skin. Due to its composition, it re-densifies the skin by immediately reducing the depth of wrinkles. Fight the expression lines. Daily use.*

#### Properties:

- Highly moisturizing and moisturizing
- Visibly improves the skin's lipid barrier
- Stimulates skin cell regeneration
- Softens expression lines, reducing wrinkle depth
- Fills the fine lines and skin wrinkles

**Application:** apply to the clean skin both the facial area, as neck and neckline with gentle circular massages, until completely absorbed. It can be applied day and night depending on the need of the skin.

## Sérum hyaluronic

### Hyaluronic concetrate serum

u.m.vta: 1



12



30 ml

REF.06799

Rellenador de arrugas. Efecto antiedad, contrarresta los efectos del paso del tiempo, dejando la piel más hidratada, elástica y luminosa.

Se trata de un sérum con alta concentración de ácido hialurónico que ayuda a rehidratar la piel y a prevenir la pérdida de agua, a la vez que refuerza sus defensas y mejora considerablemente su volumen, firmeza y suavidad.

Aplicación: aplicar mañana y noche antes de la crema hidratante, sobre la piel del rostro, cuello y escote limpio y seco. Masajear hasta su total absorción.

*Wrinkle filling. Anti-aging effect, counteracts the effects of the passage of time, leaving the skin more hydrated, elastic and luminous. It is a serum with a high concentration of hyaluronic acid that helps rehydrate the skin and prevent water loss, while strengthening its defenses and greatly improving its volume, firmness and smoothness.*

*Application: apply morning and night before the moisturizer, on the skin of the face, neck and clean and dry neck live. Massage until completely absorbed.*







## Crema hidratante de día Moisturising day cream

u.m.vta: 1  1200

3 ml

REF.06653

Nueva  
fórmula  
New  
formula

u.m.vta: 1  24 

50 ml

200 ml

REF.06451

REF.07184



## Hidra-nutrive day - Premium

Tratamiento hidro-nutritivo que estimula y reestablece los mecanismos de la piel. Gracias a sus activos: agua de glaciador liposomada, ácido hialurónico, ceramidas, aloe vera y aceite de argán, restaura la barrera lipídica natural de la piel, previniendo la pérdida de agua transepidérmica (TWEL). Mejora la suavidad, el balance hídrico y la flexibilidad de la piel.

### Cream hydro nutritive day - premium

Hydro-nutritive treatment that stimulates and re-establishes the skin's mechanisms. Thanks to its assets: liposomated glacial water, hyaluronic acid, ceramides, aloe vera and argan oil, restores the natural lipid barrier of the skin, preventing the loss of transepidermal water (TWEL). Improves softness, water balance and skin flexibility.

## Crema nutritiva de noche Nourishing night cream

u.m.vta: 1  1000

3 ml

REF.07297

u.m.vta: 1  24 

50 ml

200 ml

REF.03541

REF.07437



## Aceite de argán y aloe vera

Crema hidratante enriquecida con aceite de argán y aloe vera. Indicada para todo tipo de pieles. Sus principios activos estimulan la capacidad celular contra los radicales libres y ayudan a la regeneración de la dermis. Aporta luminosidad, tersura y firmeza a la piel. Rápida absorción. Aplicar diariamente preferiblemente por la noche.

### Argan oil and aloe vera

Moisturizing cream enriched with argan oil and aloe vera. Indicated for all skin types. Its active principle stimulate the cellular capacity against free radicals, and help the regeneration of the dermis. Brings luminosity, smoothness and firmness to the skin. Rapid absorption. Apply daily preferably in at night.



## Crema nutritiva caviar

### Nourishing caviar cream

u.m.vta: 1  1200

3 ml

REF.06654

u.m.vta: 1  18 

50 ml

REF.03543

u.m.vta: 1  12 

200 ml

REF.06452

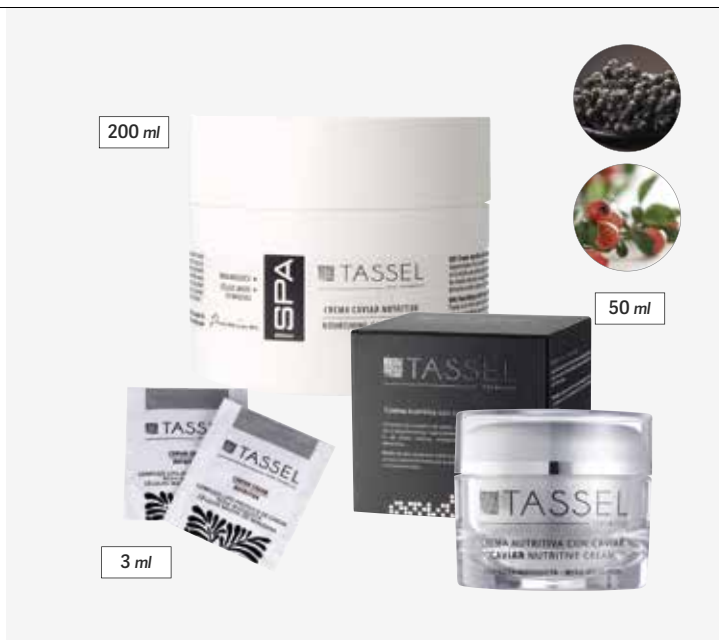



Complejo lipo-protéico de caviar, rico en vitaminas, aminoácidos y oligoelementos. Indicada para pieles deshidratadas y maduras, con alto poder regenerante gracias a la rosa mosqueta. Previene y suaviza los signos del envejecimiento y los causados por las agresiones externas. Rápida absorción. Para mejores resultados, preferiblemente aplicar 2 veces al día.

*Protein lipo-protein complex, rich in vitamins, amino acids and trace elements. Indicated for dehydrated and mature skins with high regenerating power thanks to musk rose. Prevents and softens the signs of aging and those caused by external aggressions. Rapid absorption. For best results, preferably apply 2 times a day.*

## Crema E-Pigment despigmentante

### Depigmenting E-Pigment cream

u.m.vta: 1  24 

50 ml

REF.06800

Esencialmente formulada para actuar sobre las zonas más oscuras del rostro, ayudando a frenar la producción de melanina y estimulando la generación de nuevas células que renuevan la piel, recuperando así su tono habitual. Enriquecida con glycyrrhiza glabra root extract, kojic acid, alfa hidroxiácidos.

- Aclara y reduce la intensidad de las manchas
- Aumenta la luminosidad y homogeniza del tono de la piel
- Mejora la hidratación y la función barrera de la piel
- Protege la piel del daño solar y previene la aparición de manchas

*Primarily formulated to work on the darkest areas of the face, helping to stop the production of melanin and stimulating the generation of new cells that renew the skin, thus recovering its normal tone. Enriched with glycyrrhiza glabra root extract, kojic acid, alpha-hydroxy acids.*

- Clarifies and reduces the intensity of stains
- Increases luminosity and makes the skin tone more uniform
- Improves skin's hydration and barrier function
- Protects the skin from sun damage and prevents the appearance of spot







## Crema hidratante de oro Moisturising gold cream

u.m.vta: 1  1200



3 ml

REF.06655

u.m.vta: 1  18 

50 ml

REF.04980

u.m.vta: 1  24 

200 ml

REF.07185



### Oro y rosa mosqueta

Indicada para pieles maduras, uso diario. Los oligoelementos naturales estimulan la capacidad celular contra los radicales libres, ayudan a la regeneración de la dermis, actúan contra la flacidez y aportan luminosidad, tesura y firmeza a la piel.

Emulsionante de última generación: emulsionante no iónico, natural y libre de PEG.

Propiedades humectantes significativas y mejora visiblemente de la textura de la piel.

**Oro:** potencia la luminosidad (ideal para pieles apagadas y muy morenas) tiene además un efecto tensor y regenerador, piel visiblemente más joven

**Argirelox:** este péptido es un ingrediente activo que lucha contra las arrugas de expresión atenuando la contracción muscular en la vía pre-sináptica

**Pollushield:** ingrediente funcional que actúa como una barrera entre la piel y los contaminantes en el medio ambiente y también aumenta el potencial antioxidante de la piel

**Rosa Mosqueta:** antiarrugas natural que favorece la producción de colágeno, elastina y ácido hialurónico, que dan firmeza y elasticidad a la piel

### Gold and musk rose

Indicated for mature skin, daily use. The natural trace elements stimulate the cellular capacity against free radicals, help the regeneration of the dermis, act against flaccidity and bring luminosity, and firmness to the skin.

State-of-the-art emulsifier: non-ionic, natural and PEG-free emulsifier. Clinically proven, it has significant moisturizing properties and visibly improves the texture of the skin.

**Gold:** strengthens luminosity (ideal for dull and very dark skin) and it also has a tensor and regenerating effect, visibly younger skin

**Argirelox:** this peptide is an active ingredient that fights against expression wrinkles by attenuating muscle contraction in the pre-synaptic pathway

**Pollushield:** functional ingredient that acts as a barrier between the skin and contaminants in the environment and also increases the antioxidant potential of the skin

**Musk-Rose:** natural anti-wrinkle that promotes the production of collagen, elastin and hyaluronic acid, which give firmness and elasticity to the skin

**Active cells · antiedad · células madre vegetales**  
**Active cells · anti-aging · plant stem cells**



El extracto de células madre de origen vegetal previene y ralentiza el envejecimiento prematuro. Ayuda a estimular la regeneración del tejido cutáneo, aportándole firmeza, elasticidad y atenuando las manchas y arrugas producidas por el paso del tiempo. Sérum de rápida absorción por su textura ligera. Aplicar el sérum antes de la crema y utilizar ambos productos para un resultado más eficaz.

**Propiedades:**

Antienvejecimiento y antiedad al ralentizar el proceso del envejecimiento y estimular la regeneración celular en el tejido cutáneo. Reparación de los efectos nocivos del medio ambiente, especialmente de la contaminación y la radiación UV.

*Vegetable stem cell extract prevents and slows premature ageing. It helps stimulate the regeneration of skin tissue, providing it with firmness and elasticity and softening the spots and wrinkles that arise over time. This serum can be absorbed rapidly owing to its light texture; simply apply the serum before the cream and use both products at the same time for the most effective results.*

**Properties:**

*Anti-ageing effect by slowing the ageing process and stimulating cell regeneration in skin tissue. Repairs the harmful effects of the environment, especially pollution and UV radiation.*

**Expositor Tassel Active Cells**  
**Tassel Active Cells Display**

u.m.vta: 1	 1
------------	---

**REF.03926**

Expositor compuesto por:



- 5 cremas Active · Cells antiedad de células madre vegetales (REF. 03702)
- 5 sérums Active · Cells antiedad de células madre vegetales (REF. 03703)

Display containing:

- 5 Active · Cells cream anti-ageing effect based on vegetable stem cell
- 5 Active · Cells serum antiageing effect based on vegetable stem cells



**Crema**  
**Cream**

u.m.vta: 1	 1200	u.m.vta: 1	 24	
------------	--	------------	--	---

3 ml

**REF.06656**

50 ml

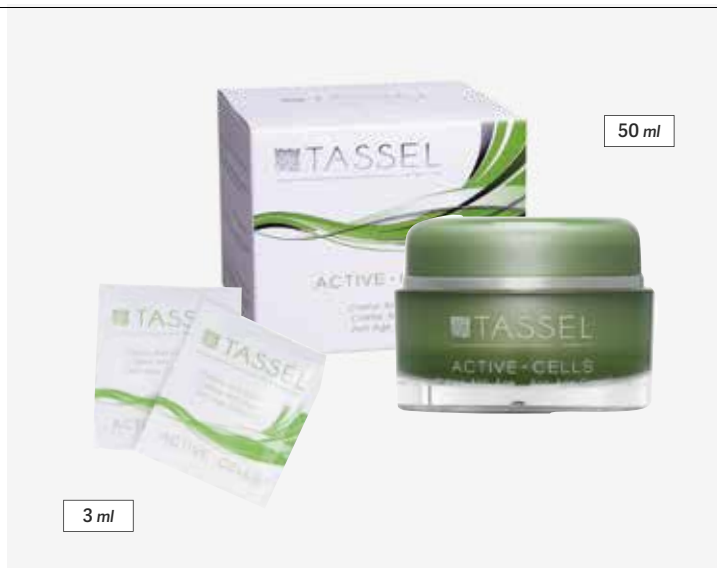

**REF.03702**



Crema semi-fluida, de rápida absorción. Indicada para pieles maduras. Utilizar después del sérum para un tratamiento más eficaz. Se recomienda el uso diario día y noche.

*Semi-fluid cream, fast absorption. Indicated for mature skin. Use after the serum for a more effective treatment. Daily use is recommended day and night.*

**Sérum**  
**Serum**

u.m.vta: 1	 6	
------------	---	---

30 ml

**REF.03703**

Sérum de rápida absorción de textura ligera. Aplicar el sérum antes de la crema. Utilizar ambos productos para un resultado más eficaz. Uso diario.

*Sérum of fast absorption of light texture. Apply the serum before the cream. Use both products for a more effective result. Daily use.*







### Expositor Tassel Professional Line Tassel Professional Line Display

u.m.vta: 1		1
------------	---	---

**REF.04664**

Expositor para cremas compuesto de:



- 3 cremas de día Hydra-Nutrive (REF. 06451)
- 3 cremas de noche Hydra- Nutrive (REF. 03541)
- 3 cremas hidratante de oro (REF. 04980)
- 3 cremas nutritiva de caviar (REF. 03543)
- 6 colágeno puro (REF. 07762)
- Sachets + poster

Creams display containing:

- 3 Hydra-Nutrive Day creams (REF. 06451)
- 3 Hydra-Nutrive Night creams (REF. 03541)
- 3 gold moisturising creams (REF. 04980)
- 3 caviar extract nourishing creams (REF. 03543)
- 6 pure collagen (REF. 07762)
- Sachets + poster



## Colágeno Collagen

u.m.vta: 1  6 

30 ml

REF.07762

### Efecto inmediato

Concentrado de colágeno. Gracias a su poder reafirmante y a su concentración se corrige gradualmente la flacidez del rostro, en especial en las zonas del contorno de ojos, labios, cuello, etc. Uso diario. No engasa y es de rápida absorción. Aplicar diariamente.

### Immediate effect

Collagen concentrate. Its firming effect and concentration allow it to gradually correct sagging in the face, especially around the eyes, lips, neck, etc. For daily use. The texture is not geasy and it is absorbed quickly by the skin. To be applied daily.





## Contorno de ojos Focus 3 Focus 3 eye contour

u.m.vta: 1  1200

3 ml

REF.06658

u.m.vta: 1  6 

30 ml

REF.03741



Crema de textura fresca y ligera que ayuda a la reparación de las pequeñas arrugas del contorno de ojos gracias a sus principios activos:

1. Vitamina C: antioxidante y antirradical libre

Manzanilla: calmante y descongestiva

Beta-carotenos: anti-envejecimiento

2. Proporciona tersura, ayuda a combatir las bolsas, ojeras y signos de fatiga. De uso diario

Cream with a fresh and light texture that helps repair the small wrinkles around the eyes thanks to its active principles:

1. Vitamin C: anti-oxidant and anti-free radicals

Chamomile: soothing and decongestive effect

Beta-carotenes: anti-ageing effect

2. Provides firmness, helps combat bags, shadows and signs of fatigue. Daily use



SCAN  
ME!

### Mousse limpiadora T-PURITY T-PURITY mousse cleaner

u.m.vta: 1



12



200 ml

REF.06084



Excelentes propiedades seborreguladoras, hidratantes y acondicionadoras de la piel que eliminan delicadamente el maquillaje, las impurezas y el exceso de grasa sin irritar la piel. Su textura líquida se transforma en una espuma ligera y suave que proporciona una limpieza en profundidad, hidratando y manteniendo el equilibrio cutáneo. Recupera un aspecto mate y aterciopelado. Por sus activos, aporta beneficios: poros afinados y reducidos, brillos difuminados, textura cutánea suavizada y purificada, apariencia suave y matificada.

*Excellent sebum-regulating, moisturizing and conditioning properties of the skin that delicately eliminates make-up, impurities and excess of fat without irritating the skin. Its liquid texture is transformed into a light and soft foam that provides a deep cleaning, hydrating and maintaining skin balance. Recovers a matt and velvety look. For its assets, it provides benefits: pore refined and reduced, diffuse shine, soft and purified skin texture, smooth and matted appearance.*

### Crema astringente T-PURITY T-PURITY astringent cream

u.m.vta: 1



1200

3 ml

REF.06657

Crema-gel fresco y de textura ligera, formulado con activos hidratantes, seborreguladores y matificantes del brillo causado por el exceso de grasa en la piel. Minimiza los poros, los puntos negros y las espinillas. Está formulado con activos vegetales que actúan como antiinflamatorio, reestructurantes de la barrera lipídica, matificantes y seborreguladores.

*Fresh and light texture cream-gel, formulated with moisturizing, sebo regulator and mattifying the shine caused by excess oil in the skin. Minimizes pores, blackheads and pimples. It is formulated with plant assets that act as an anti-inflammatory, restructuring of the lipid barrier, mattifying and sebo regulator.*

u.m.vta: 1



12



50 ml

REF.06086



50 ml

3 ml

### Línea pieles grasas astringente Astringent Line oil skin

### Tónico astringente T-PURITY T-PURITY astringent tonic

u.m.vta: 1



12



200 ml

REF.06085



Tónico facial astringente, formulado especialmente para pieles grasas, regula el exceso de grasa, evita los brillos y ayuda a eliminar las imperfecciones.

Gracias a sus activos cierra los poros, ayuda a conseguir un efecto mate y suave en la piel, controlando los brillos y la grasa en la piel. Combate y previene las imperfecciones: propiedades reguladoras del sebo, ayuda a controlar la proliferación bacteriana, evitando la infección de los poros que provoca la aparición del acné.

*Facial astringent tonic, formulated especially for oily skin, regulates excess fat, prevents shine and helps eliminate imperfections. Thanks to its actives, it closes the pores. It helps to achieve a matt and soft effect on the skin, controlling the shine and fat on the skin. Combat and prevent imperfections: regulating properties of sebum, helps control bacterial proliferation, preventing infection of the pores that causes the appearance of acne.*



### Expositor de madera aceites esenciales Wooden display essential oils

u.m.vta: 1	 1
------------	---

REF.04995

- 42 Aceites esenciales
- 6 modelos de 15 ml por cada referencia (x6)
- 1 modelo de 30 ml por cada referencia (x6)
- Regalo 20 folletos

- 42 essential oils
- 6 models of 15 ml for each reference
- 6 model of 30 ml for each reference
- Gift 20 brochures



### Expositor madera aceites esenciales Wooden display essential oils

u.m.vta: 1	 1
------------	---

Vacío  
Empty

REF.04995/01



## Aceites esenciales

### Essential oils

La mayoría de los aceites esenciales se obtienen a través de la destilación y presión en frío, de esta forma se consigue obtener un líquido que representa la esencia pura de la planta y nos permite disfrutar de todas sus propiedades.

*The majority of essential oils are obtained through distillation and cold pressing, in this way we obtain a liquid that represents the pure essence of the plant and allows us to enjoy all its properties.*

#### Aceite Esencial Naranja Dulce · Sweet Orange Essential Oil

u.m.vta: 1



6



15 ml

REF.07752

Propiedades antioxidantes y antimicrobianas. Atenúa las arrugas, mejorar la firmeza de la piel. Ayuda combatir la celulitis y la retención de líquidos, Reduciendo el estancamiento de los líquidos. El aceite esencial de naranja también tiene otros usos como repelente de mosquitos.

*Antioxidant and antimicrobial properties. Reduces wrinkles, improve skin firmness. Helps combat cellulite and fluid retention, reducing fluid stagnation.*

*Orange essential oil also has other uses as a mosquito repellent.*

30 ml

REF.07753

#### Aceite Esencial de Limón · Lemon Essential Oil

u.m.vta: 1



6



15 ml

REF.07754

Hidrata, nutre y repara la piel la piel dañada. Antiarrugas y antioxidante Da brillo a la piel apagada. Favorece la circulación sanguínea, Antiséptico y Astringente.



*Hydrates, nourishes and repairs damaged skin. Anti-wrinkle and antioxidant Brightens dull skin. Promotes blood circulation, Antiseptic and Astringent.*

30 ml

REF.07755

NEW



**Aceite Esencial Bergamota · Bergamot Essential Oil**u.m.vta: 1  6 



15 ml

**REF.07756**

Propiedades Antiinflamatorias, Antibacteriana y Antiséptico (impide el desarrollo de microorganismos), antiacné, cicatrizante.

*Anti-inflammatory, antibacterial and antiseptic properties (prevents the development of microorganisms), anti-acne, healing.*

30 ml

**REF.07757****Aceite Esencial Salvia · Sage Essential Oil**u.m.vta: 1  6 



15 ml

**REF.07758**

Para todo tipo de pieles, regula el sebo de la piel y la tonifica. Propiedades antisépticas, evitando el crecimiento de microorganismos. Esto ayuda con diferentes tipos de problemas de la piel, como el eccema o los piojos. Evitar la sequedad del cuero cabelludo y ayudar a prevenir la caída del cabello.

*For all skin types, it regulates the skin's sebum and tones it. Antiseptic properties, preventing the growth of microorganisms. This helps with different types of skin problems, such as eczema or lice. Prevent dryness of the scalp and help prevent hair loss.*

30 ml

**REF.07759****Aceite Esencial Ylang-Ylang · Ylang-Ylang Essential Oil**u.m.vta: 1  6 

15 ml

**REF.07760**

Antiséptica, antimicrobiana, y antiinflamatoria. Mejora el aspecto de la piel, regenerándola tras haber sufrido alteraciones tales como eczemas, dermatitis o acné. Mejorar la circulación sanguínea, estimulando el rejuvenecimiento celular. Ayuda a la circulación y a desintoxicar la piel, hace que la celulitis sea mucho menos visible.

*Antiseptic, antimicrobial, and anti-inflammatory. It improves the appearance of the skin, regenerating it after having suffered alterations such as eczema, dermatitis or acne. Improve blood circulation, stimulating cell rejuvenation. It helps circulation and detoxifies the skin, making cellulite much less visible.*

30 ml

**REF.07761****NEW**



u.m.vta: 1

6



15 ml

REF.06044

**Aceite esencial lavanda · Lavender essential oil**

Es un antibiótico natural y un agente antiséptico y cicatrizante. Drena, combate la celulitis, ayuda a diluir los nódulos subcutáneos y es un gran antiséptico. Actúa eficazmente contra los microorganismos bacterianos y fúngicos. Antiinflamatorio, combate problemas dérmicos tales como el acné. También ayuda a regenerar la dermis después de quemaduras, ya que activa el metabolismo celular. La lavanda contribuye en la regeneración activa del tejido para mantener la piel más joven. Aporta un extra de hidratación. También se pueden aplicar unas gotas de este aceite en cualquier tratamiento facial o corporal.

30 ml

REF.06049

*It is a natural antibiotic and an antiseptic and healing agent. Drains, fights cellulite, helps dilute subcutaneous nodules and is a great antiseptic. Acts effectively against bacterial and fungal microorganisms. Anti-inflammatory, combat skin problems such as acne. It also helps to regenerate the dermis after burns, as it activates cellular metabolism. Lavender contributes to the active regeneration of the tissue to keep the skin younger. Provides an extra hydration. You can also apply a few drops of this oil in any facial or body treatment.*



15 ml

REF.06052

**Aceite esencial rosa mosqueta · Musk rose essential oil**

Es un gran regenerador de la piel. Actúa de forma superficial como factor natural humectante, mejorando la hidratación. Nutre y regenera atenuando visiblemente las cicatrices y las arrugas. Corrige y previene los problemas cutáneos debidos al fotoenvejecimiento, a través de la autogeneración de melanina. Para evitar estrías durante el embarazo es recomendable su uso durante el último trimestre de la gestación en abdomen y pechos. Contribuye a redistribuir la pigmentación permitiendo que se atenúen o eliminen las manchas, debidas a casos de acné, manchas solares, etc. Acción tonificante, cicatrizante, rejuvenecedora y evita la oxidación de las células.

30 ml

REF.06053

*It is a great skin regenerator. It acts superficially as a natural moisturizing factor, improving hydration. Nourishes and regenerates visibly attenuating scars and wrinkles. Corrects and prevents skin problems due to photoaging, through the self-generation of melanin. To avoid stretch marks during pregnancy, it is recommended to use during the last trimester of pregnancy in the abdomen and breasts. It contributes to redistribute the pigmentation allowing the spots to be attenuated or eliminated, due to cases of acne, sunspots, etc. Toning action, healing, rejuvenating and prevents oxidation of cells.*



15 ml

REF.06043

**Aceite esencial eucalipto · Eucalyptus essential oil**



Efecto adelgazante, retención de líquidos, astringente, actúa como antibacteriano en afecciones cutáneas, pediculosis y caspa, efecto refrescante, contrae los vasos sanguíneos periféricos. (Ideal piernas cansadas para masajear). Añadiendo unas gotas de este aceite en el champú diario, es una gran opción para la estimulación de los folículos del cabello y cuero cabelludo así como para combatir la caspa. También se pueden aplicar unas gotas de este aceite en cualquier tratamiento facial o corporal.

30 ml

REF.06048

*Slimming effect, fluid retention, astringent, acts as antibacterial in skin conditions, pediculosis and dandruff, refreshing effect, shrinks peripheral blood vessels. (Ideal tired legs to massage). Adding a few drops of this oil in the daily shampoo, is a great option for the stimulation of hair follicles and scalp as well as to combat dandruff. You can also apply a few drops of this oil in any facial or body treatment.*



u.m.vta: 1  6 

15 ml

REF.06041

**Aceite esencial árbol de té · Tea tree essential oil**

Sus aplicaciones se fundamentan básicamente en sus propiedades bactericidas y antisépticas, a las que se une un suave efecto anestésico local. Sus propiedades: cicatrizante, dermoprotector, actúa directamente sobre la degradación del sudor, dermopurificante, eczemas, llagas, manchas de la cara, manos, escote. Drenante y adelgazante. También se usa para las cutículas después de haber sido eliminadas por su acción antiséptica.

*Its applications are based basically on its antibacterial and antiseptic properties, to which it joins a mild local anesthetic effect. Its properties: healing, dermoprotector, acts directly on the degradation of sweat, dermopurifying, eczema, sores, spots of the face, hands, neckline. Draining and slimming. It is also used for cuticles after they have been removed for their antiseptic action.*

30 ml

REF.06046



15 ml

REF.06042

**Aceite esencial romero · Rosemary essential oil**

**Cabello:** es recomendable para fortalecer el cabello. Estimula la circulación propiciando el crecimiento y fortaleciendo las raíces, y mejorando la estructura capilar del pelo fino y quebradizo.

**Piel:** el romero es muy utilizado en cremas cosméticas antiedad, excelente antioxidante. Algunos de sus componentes, como el ácido rosmarínico, promueven la formación de nuevas células. Es descongestivo, desinflamatorio, cicatrizante, refrescante y astringente.

*Hair: it is recommended to strengthen the hair. Stimulates circulation promoting growth and strengthening the roots, and improving the capillary structure of fine and brittle hair.*

*Skin: rosemary is widely used in anti-aging cosmetic creams, an excellent antioxidant. Some of its components, such as rosmarinic acid, promote the formation of new cells. It is decongestant, anti-inflammatory, healing, refreshing and astringent.*

30 ml

REF.06047



15 ml

REF.06045

**Aceite esencial menta · Mint essential oil**

En la piel es muy útil ya que ayuda a retener la humedad evitando el envejecimiento prematuro. Si se utiliza en masajes, en zonas puntuales puedes conseguir un efecto relajante único. Aplicando en una crema base diaria, actúa sobre el enrojecimiento cutáneo debido a la inflamación o acné. El uso del aceite esencial de menta tiene propiedades: regulación de la grasa de la piel, limpieza del acné, eliminación de edemas y retención de líquidos, reducción de la celulitis, descongestión y acción refrescante de la piel.

*The skin it is very useful because it helps to retain moisture avoiding premature aging. If used in massages, in specific areas you can get a unique relaxing effect. Applying in a daily base cream, acts on skin redness due to inflammation or acne. The use of essential oil of mint has properties: regulation of skin fat, cleansing of acne, elimination of edema and fluid retention, reduction of cellulite, decongestion and refreshing action of the skin.*

30 ml

REF.06050



## Mascarilla facial · Facial mask

### Pieles normales y mixtas Normal and mixed skin

u.m.vta: 1  12

400 ml

REF.04454



#### Zona T: frente, nariz y barbilla

Se trata de una combinación de piel seca y piel grasa. Unas zonas suelen tener más exceso de sebo como la zona T (frente, nariz y barbilla) y otras zonas sufren más de deshidratación, como suele suceder en la zona U (zona de debajo de los pómulos y mandíbula).

Sus activos de origen vegetal, rheum rhaponticum root extract, actúan activando los mecanismos naturales de hidratación de la piel, consiguiendo: reconstrucción del estrato córneo y sus componentes, regulación de la descamación, restauración de la función barrera.

#### Zone T: front, chin and nose

It is a combination of dry skin and oily skin. Some areas tend to have more excess sebum such as the T zone (forehead, nose and chin) and other areas suffer more from dehydration, as usually happens in the U zone (area under the cheekbones and jaw).

Its plant-derived assets, rheum rhaponticum root extract, act by activating the skin's natural hydration mechanisms, achieving: reconstruction of the stratum corneum and its components, regulation of desquamation, and restoration of the barrier function.

### Pieles secas Dry skin

u.m.vta: 1  12

400 ml

REF.04974



#### Gan hidratación

Las pieles secas siempre necesitan un aporte importante de hidratación y un cuidado más especial, ya que suelen enrojecerse con facilidad y son más sensibles. Por ello, la mascarilla facial para pieles sensibles, gracias a sus principios activos de origen vegetal, salix alba (willow) bark extract, alternifolia melaleuca, curculigo orchioides root extract, actúan sobre el mecanismo interno de control del pH cutáneo, reparando la función barrera y causando una disminución de la reactividad y sensibilidad de la piel. Así pues, mejora la cohesión entre las células, devolviendo de esta forma la integridad de la epidermis.

#### Get hydration

Dry skin always needs an important supply of hydration and more special care, as they tend to redden easily and are more sensitive. Therefore, the facial mask for sensitive skin, thanks to its active ingredients of plant origin, salix alba (willow) bark extract, alternifolia melaleuca, curculigo orchioides root extract, act on the internal mechanism of cutaneous pH control, repairing the barrier function and causing a decrease in skin reactivity and sensitivity. Thus, it improves the cohesion between the cells, thus returning the integrity of the epidermis.

### Pieles grasas Oily skin

u.m.vta: 1  12

400 ml

REF.03810



#### Equilibra el exceso de grasa

Mantiene un equilibrio hídrico hidratante y evita que cualquier agente externo como sudor, humedad, etc., produzca bacterias. Uno de sus componentes es el encargado de ejercer una acción absorbente contra la humedad. Esto permite dejar sobre la piel, un film protector que va cediendo la piel, ejerciendo su función de catarsis y hidratación. Su activo barosma betulina leaf extract, equilibra el exceso de grasa y trata los poros visibles disminuyéndoles en número y tamaño, equilibrando la secreción sebácea y mejorando visiblemente la textura de la piel.

#### Balances excess fat

Maintains a hydrating water balance and prevents any external agent such as sweat, moisture, etc., from producing bacteria. One of its components is responsible for exerting an absorbent action against moisture. This allows to leave on the skin, a protective film that cedes the skin, exerting its function of catharsis and hydration. Its active barosma betulina leaf extract, balances excess fat and treats visible pores by decreasing these in number and size, balancing sebaceous secretion and visibly improving skin texture.



## Sauna facial

### Facial sauna

u.m.vta: 1  4

105 W

REF. 03280

- Indicado para la limpieza de la piel y para el alivio de enfermedades respiratorias
- Accesorios: vaso medidor y accesorio para la nariz. Difusor para que el spray sea constante. Calefacción PTC de alta calidad
- Fácil de limpiar
- Potencia: 105 W

- Indicated for cleansing the skin and for the relief of respiratory diseases
- Accessories: measuring cup and accessory for the nose. Diffuser so that the spray is constant. PTC heating of high quality
- Easy to clean
- Power: 105 W



## Vaporal facial

### Facial steamer

u.m.vta: 1  1

1 L

REF.04952

SCAN  
ME!

Sólo utilizar con agua destilada. Con función de vapor frío y caliente. El vaporal incorpora la función de vapor de OZONO, lo que genera más vapor de agua tanto en vapor frío como caliente. Cuando el agua esté por debajo del mínimo, el vaporal se apagará automáticamente por seguridad. El cabezal puede rotar 120°.

- Voltaje: 220-240V
- Frecuencia: 50-60Hz
- Potencia: 650 W
- Depósito capacidad: 1L

Only use with distilled water. With cold and hot steam function. The steam incorporates the OZONE steam function, which generates more water steam in both cold and hot. When the water is below the minimum, the vapor will automatically turn off due to safety. The upper part can rotate 120°.

- Voltage: 220-240V
- Frequency: 50-60Hz
- Power: 650 W
- Capacity deposit: 1L





**Bolsa 10 mini espátulas transparentes para crema**  
**Bag 10 transparent mini cream spatulas**

u.m.vta: 1  100

**REF.07328**





**Cepillo facial masaje**  
**Facial massage brush**

u.m.vta: 1  20 

**REF.01811**

Ideal para exfoliar  
*Ideal for scrub*

u.m.vta: 1  50 

**REF.06660**

Con capuchón protector de las cerdas  
*With a protective soft nylon tines cap*



**Sacabarros**  
**Blacket removal**

u.m.vta: 1  50

Lanceta grande  
*Large*

**REF.01477**



u.m.vta: 1  50

Lanceta pequeña  
*Small*

**REF.01478**



u.m.vta: 1  40

Doble uso  
*2 sizes*

**REF.01479**



## Esponjas konjac Konjac sponges

u.m.vta: 1	 12	
------------	--	---

Esponjas de textura extra fina y fabricadas a partir de las raíces de konjac, rica en minerales. Es 100% natural, biodegradable, sostenible y respetuoso con el medio ambiente. Libre de colorantes, conservantes y pigmentos artificiales. Antimicrobiano gracias a su naturaleza alcalina y con gran capacidad para limpiar la piel. Con el uso de la esponja, no es necesario utilizar jabón ni limpiadores, ya que la esponja por sí sola tiene capacidad de eliminar toda la suciedad e impurezas de la piel.

*Sponges of extra fine texture and made from the roots of konjac, rich in minerals. It is 100% natural, biodegradable, sustainable and respectful with the environment. Free of dyes, preservatives and artificial pigments. Antimicrobial thanks to its alkaline nature and it has great ability to cleanse the skin. With the use of the sponge, it is not necessary to use soap or cleansers, since the sponge alone has the ability to remove all dirt and impurities from the skin.*

REF.04970



### Carbón de leña de bambú natural

- Elimina el exceso de sebo, exfolia suavemente, limpia los poros en profundidad que pueden provocar bacterias que causan el acné
- Elimina los puntos negros dejando tras de sí una película para nutrir y mejorar la barrera protectora de la piel, sin necesidad de usar abrasivos químicos
- Equilibra el pH de la piel
- Especialmente indicado para pieles grasas y con tendencia acnéica
- No apta para pieles sensibles
- Debe reemplazarse la esponja cada 2 meses

### Natural bamboo charcoal

- It removes excess sebum, exfoliates gently, cleans pores in depth that can cause bacteria that cause acne
- Eliminates blackheads leaving behind a film to nourish and improve the protective barrier of the skin, without the need to use chemical abrasives
- Balances the pH of the skin. Especially indicated for oily skin and with acne tendency
- Not suitable for sensitive skin
- The sponge should be replaced every 2 months

REF.04971

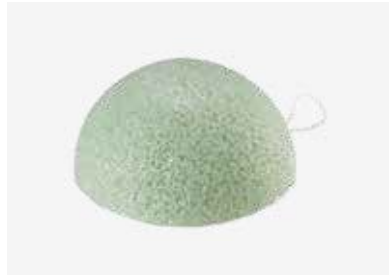

### Aloe vera. Calmante, hidratante y humectante

- Equilibra el pH de su piel
- Deja una película para nutrir y mejorar la barrera protectora de la piel
- Puedes utilizarla tras la depilación ya que te ayudará a calmar y humectar la piel
- Ideal para pieles normales y mixtas
- Debe reemplazarse la esponja cada 2 meses

### Aloe vera. Smoothing, moisturizing and moisturizing

- It balances the pH of your skin
- Leave a film to nourish and improve the protective barrier of the skin
- You can use it after waxing because you it will help soothe and moisturize the skin
- Ideal for normal and combination skin
- The sponge should be replaced every 2 months

REF.04972



### Semillas de rosa búlgara. Hidrata, nutre y regenera

- Deja una película que humecta, nutre y mejora la barrera protectora de la piel
- Reduce la necesidad de usar jabones que puedan irritar su delicada piel
- Posee un efecto calmante natural
- Especialmente indicado para pieles muy sensibles e incluso en edades tempranas
- Debe reemplazarse la esponja cada 2 meses

### Bulgarian rose seeds. Hydrates, nourishes and regenerates

- It leaves a film that moisturizes, nourishes and improves the protective barrier of the skin
- Reduces the need to use soaps that they can irritate your delicate skin
- It has a natural calming effect
- Especially suitable for very skins sensitive and even at early ages
- The sponge should be replaced every 2 months

02

## Línea de cuidado corporal Body care line

*Cremas, tratamientos y accesorios...*

*Creams, treatments, accessories...*





## Aceites base · Base oils

Los aceites bases son también conocidos como aceites portadores o aceites vehiculares. Actúan como portadores (vehículos) en la aplicación de los aceites esenciales en el rostro y el cuerpo facilitando el movimiento necesario en el masaje por la lubricación que ofrecen y a su vez, aportan las propiedades terapéuticas propias a la mezcla. Son aceites fijos, es decir, no se evaporan (a diferencia de los esenciales que sí lo hacen).

Enriquecidos con aceite de pepita de uva. Propiedades altamente emolientes, protectoras, ideal como vehículo de penetración para otros componentes cuando se combina con principios activos diversos. Por su alto contenido en antioxidantes, vitaminas C, D, E y betacaroteno, aumenta la resistencia de la piel haciéndola más elástica. Se absorbe muy rápidamente y puede usarse en cualquier tipo de piel.

*Oils bases are also known as carrier oils or vehicular oils. They act as carriers (vehicles) in the application of essential oils on the face and body, facilitating the movement necessary in the massage due to the lubrication they offer and, at the same time, provide the therapeutic properties proper to the mixture. They are fixed oils, that is, they do not evaporate (unlike the essential oils that do). Enriched with grape seed oil. Highly emollient and protective properties, ideal as a penetration vehicle for other components when combined with various active ingredients. Due to its high content of antioxidants, vitamins C, D, E and betacarotene, it increases the resistance of the skin, making it more elastic. It is absorbed very quickly and can be used on any type of skin.*



### Aceite base caléndula Calendula base oil

u.m.vta: 1  4 

1 L

REF.06036

Tiene propiedades antiinflamatorias y calmantes, para después de someter la piel a tratamientos agresivos como la depilación o una exfoliación, el uso del aceite produce una sensación de relax y alivio de rojeces. Gan poder hidratante, nutritivo y desmaquillante. Especialmente útil para pieles sensibles como las de los bebés o personas que sufren irritaciones constantes. Apto para pieles secas o muy secas. Rico en vitamina E. Puede usarse directamente como desmaquillante, sobre todo en pieles muy sensibles que se irritan fácilmente.

*It has anti-inflammatory and soothing properties, so after subjecting the skin to aggressive treatments such as waxing or exfoliation, the use of oil produces a sensation of relaxation and relief of redness. Great moisturizing, nourishing and cleansing power. Especially useful for sensitive skin such as babies or people who suffer constant irritation. Suitable for dry or very dry skin. Rich in vitamin E. It can be used directly as a make-up remover, especially in very sensitive skin that irritates easily.*



**Más  
información**  
More  
information

SCAN  
ME!



## Aceites base · Base oils

### Aceite base almendras dulces

#### Sweet almond base oil

u.m.vta: 1



4



1 L

REF.06037

El aceite de almendras dulces es uno de los aceites por excelencia para masaje. Propiedades: da elasticidad y tersura a la piel. Buena penetración cutánea, no dejando la piel gasa. Nutritivo y regenerador. Adecuado para todo tipo de pieles incluidas las infantiles y la de los ancianos. Ideal para pieles quebradizas o agrietadas. Fortalecedor de cabellos débiles, ayuda a la desaparición de escamas en el cuero cabelludo. Es un hidratante y regenerador de pestañas natural.

*Sweet almond oil is one of the oils par excellence for massage. Properties: gives elasticity and smoothness to the skin. Good skin penetration, not leaving the skin oily. Nutritious and regenerative. Suitable for all skin types including children's and elderly. Ideal for brittle or cracked skins. Strengthener of weak hair, helps the disappearance of scales on the scalp. It is a natural eyelash moisturizer and regenerator.*



### Aceite base rosa mosqueta

#### Musk rose base oil

u.m.vta: 1



4



1 L

REF.06035

La rosa mosqueta es un gran regenerador de la piel. Actúa de forma superficial como factor natural humectante, mejorando la hidratación. Nutre y regenera atenuando visiblemente las cicatrices y las arrugas. Corrige y previene los problemas cutáneos debidos al fotoenvejecimiento, a través de la autogeneración de melanina. Contribuye a redistribuir la pigmentación permitiendo que se atenúen o eliminen las manchas. Acción tonificante, cicatrizante, rejuvenecedora y evita la oxidación de las células.

*Musk rose is a great skin regenerator. It acts superficially as a natural moisturizing factor, improving hydration. Nourishes and regenerates visibly attenuating scars and wrinkles. Corrects and prevents skin problems due to photoaging, through the self-generation of melanin. It contributes to redistribute the pigmentation allowing the spots to be attenuated or eliminated. Toning, healing, rejuvenating action and prevents oxidation of cells.*



### Aceite base jojoba

#### Jojoba base oil

u.m.vta: 1



4



1 L

REF.06038

Excelente penetración cutánea no deja la piel gasa debido a su buena capacidad de absorción. Recomendado para pieles gasas así como para tratamiento anti-acné por sus propiedades bactericidas y como tratamiento antiséborreico ya que disuelve el sebo que se deposita en los folículos pilosos activos, obstruyendo el crecimiento capilar. Excelente aceite capilar ya que nutre los cabellos secos y quebradizos. Actúa como protector ante las posibles irritaciones o alteraciones cutáneas producidas por tintes y permanentes.

*Its excellent skin penetration does not leave the skin oily due to its good absorption capacity. Recommended for oily skin as well as for anti-acne treatment for its bactericidal properties, as anti-seborrheic treatment, dissolves the sebum that is deposited in active hair follicles, obstructing hair growth. Excellent capillary oil as it nourishes dry and brittle hair. It acts as a protector against possible irritations or skin changes caused by dyes and perms.*



Más  
información  
More  
information

SCAN  
ME!

## Aceites base · Base oils

### Aceite base árbol de té Tea tree base oil

u.m.vta: 1		4	
------------	---	---	---

1 L
-----

REF.06051

Sus aplicaciones se fundamentan básicamente en sus propiedades bactericidas y antisépticas, a las que se une un suave efecto anestésico local. Sus propiedades: cicatrizante, dermatoprotector, actúa directamente sobre la degradación del sudor, dermopurificante, eczemas, llagas, manchas de la cara, manos, escote. Drenante y adelgazante. También se usa para las cutículas después de haber sido eliminadas por su acción antiséptica.

*Its applications are based basically on its antibacterial and antiseptic properties, to which it joins a mild local anesthetic effect. Its properties: healing, dermatoprotector, acts directly on the degradation of sweat, dermopurificante, eczema, sores, spots of the face, hands, neckline. Draining and slimming. It is also used for cuticles after they have been removed for their antiseptic action.*



### Aceite base oliva Olive base oil

u.m.vta: 1		4	
------------	---	---	---

1 L
-----

REF.06039

Propiedades emolientes, antioxidantes, tónicos, hidratantes y calmantes. Tiene un perfil lipídico muy similar al de la piel del ser humano. Restaura la humedad y la función barrera de la piel, favoreciendo la regeneración celular. Su aplicación en la piel actúa como emoliente reparando y protegiendo de un envejecimiento prematuro. Actividad antimicrobiana y antibacteriana.

*Emollient, antioxidant, toning, moisturizing and soothing properties. It has a lipid profile very similar to that of the human skin. Restores moisture and skin barrier function, promoting cell regeneration. Its application on the skin acts as an emollient repairing and protecting from premature aging. Antimicrobial and antibacterial activity.*



### Aceite base argán Argan base oil

u.m.vta: 1		4	
------------	---	---	---

1 L
-----

REF.06040

Contiene antioxidantes como la vitamina E y es rico en ácidos grasos. Regenerante y reafirmante de tejidos ya que refuerza las fibras de colágeno y elastina, mejora la barrera cutánea permitiendo la reducción de la pérdida de hidratación, antiinflamatorio para usar después de la exposición al sol, nutritivo y regenerador. Gracias a su contenido en tocoferoles posee un gran poder anti-oxidante, actuando en profundidad en la desnutrición de la piel. Ideal para el cabello y uñas ya que les da brillo y fortalece a través de su alta capacidad nutricional.

*It contains antioxidants such as vitamin E and is rich in fatty acids. Regenerating and reaffirming tissues since it reinforces the collagen and elastin fibers, improves the cutaneous barrier allowing the reduction of the loss of hydration, anti-inflammatory to use after sun exposure, nutritious and regenerative. Thanks to its content in tocopherols it has a great anti-oxidant power, acting in depth in the malnutrition of the skin. Ideal for hair and nails since it gives them shine and strengthens through their high nutritional capacity.*



## Exfoliante corporal Body scrub

u.m.vta: 1  20

REF.06648

### Aceite de argán y hueso de albaricoque

Exfoliante enriquecido con aceite de argán que aporta hidratación y hueso de albaricoque que ejerce un efecto exfoliante, eliminando células muertas e impurezas acumuladas.

El uso del exfoliante corporal ayuda a arrastrar las células muertas de la piel que se acumulan a pesar de la limpieza impidiendo su correcta oxigenación. Suaviza la piel, que aparece más tersa y luminosa, preparándola para recibir los tratamientos específicos cuyos principios activos penetrarán mejor tras la exfoliación. Agadable aroma afrutado. Puede usarse como exfoliante corporal habitual por las propiedades naturales y suaves del hueso de albaricoque.

No apta para pieles sensibles

### Argan oil and apricot kernel

Exfoliating enriched with argan oil that provides hydration and apricot bone that exfoliates, eliminating dead cells and accumulated impurities.

The use of the body scrub helps to drag the dead skin cells that accumulate despite the cleaning preventing proper oxygenation. Softens the skin that appears smoother and brighter preparing it to receive specific treatments whose active principles penetrate better after exfoliation.

It can be used as a regular body scrub because of the natural and gentle properties of apricot kernel.

Not suitable for sensitive skin.



## Kit exfoliante corporal y facial con espuma de goma de regalo Body and facial peeling kit with rubber sponge gift

u.m.vta: 1  12

REF.04883





## Sales del mar muerto, algas y extracto de limón

### Dead sea salts, algae and lemon extract



Para tratamientos de ayuda a la reducción del aspecto e intensidad de la celulitis o “piel de naranja”, disponemos de tratamientos reafirmantes, tonificantes y reductores. Todos ellos con productos naturales como sales del mar muerto, algas o extracto de limón. Con la ayuda de masajes circulares en las zonas más problemáticas ayudaremos a la absorción del producto.

*When it comes to treatments to help reduce the look and intensity of cellulite or the “orange peel” effect, we provide firming, toning and reducing treatments, all of which are based on natural products such as dead sea salts, algae or lemon extract. Applying circular massages to the most problematic areas helps the product to absorb completely.*

## Anticelulítica efecto calor

### Anti-cellulite heat effect

u.m.vta: 1 25

**REF.03546**

#### Sales del mar muerto, aloe vera y aceite de argán

La adecuada combinación de algas marinas tan potentes como la LAMINARIA y el FUCUS con el ruscus, la extensina yodada, o la cafeína entre otros, permite degajar y movilizar el acumulo gaso (lipólisis). La activación de la circulación y la elevación localizada de temperatura crean las condiciones necesarias para el desarrollo de estos procesos convirtiendo a esta crema en un producto idóneo para el tratamiento de la celulitis y el volumen. El aceite de argán y aloe vera poseen propiedades reestructurantes y regenerantes.

**EFEECTO CALOR.** Masajear e incidir especialmente en las zonas más problemáticas (nalgas, caderas, muslos, etc.). Previene también la llamada “piel de naranja”. Activa la microcirculación. No recomendada para pieles sensibles.

#### Salts from the dead sea, aloe vera and argan oil

*The adequate combination of seaweeds as powerful as LAMINARIA and FUCUS, with ruscus, iodine extensine, caffeine among others, allows to degade and mobilize the fatty accumulation (lipolysis). The activation of the circulation and the localized elevation of temperature create the necessary conditions for the development of these processes, converting this cream into an ideal product for the treatment of cellulite and volume. The argan oil and aloe vera have restructuring and regenerating properties.*

*HEAT EFFECT. Massaging and incising especially in the most problematic areas (buttocks, hips, thighs, etc.). It also prevents the so-called “orange skin”. Activates the microcirculation. Not recommended for sensitive skin.*

250 ml



## Reafirmante remodeladora

### Firming and contouring effect

u.m.vta: 1 20

250 ml

**REF.03932**

#### Extracto de limón, colágeno y algas

Crema reafirmante-remodeladora que reafirma la piel estimulando la actividad celular, mejora la elasticidad y la firmeza. Ayuda a eliminar toxinas y remodela la figura. Masajear e incidir en las zonas más problemáticas.

#### Lemon extract, collagen and algae

*Firming-remodeling cream that reaffirms the skin stimulating cellular activity, improves elasticity and firmness. It helps eliminate toxins and reshapes the figure. Massage and influence the most problematic areas.*

u.m.vta: 1 5

500 ml

**REF.03931**

250 ml



500 ml



## Aceite de argán + Aloe vera

### Argan oil + Aloe vera



El aceite de argán penetra rápidamente en la piel dejándola hidratada y sin exceso de grasa. El árbol de Argania Spinosa, que crece sólo en el suroeste de Marruecos, es por sus características, un árbol único en el mundo.

El aceite se extrae sin ninguna utilización de productos químicos, es un producto biológico con beneficios demostrados. Los análisis químicos realizados confirman sus valiosas propiedades dermatológicas y la combinación con el aloe vera hace que se potencien los efectos cicatrizantes y regenerativos.

*Argan oil rapidly penetrates into the skin, hydrating it without excess oiliness. The argania spinosa tree, which only grows in south-western Morocco, occupies a unique place in the world. Its oil is extracted without using chemicals, and it is an organic product with proven benefits. Chemical analyses confirm its valuable dermatological properties, and the combination with aloe vera promote its scarring and regenerative effects.*

## Loción hidratante body milk

### Moisturizing lotion body milk

u.m.vta: 1  8

**REF.04458**

#### Aceite de argán y aloe vera

Su composición rica en aceite de argán y aloe vera aporta suavidad, hidratación y un gran poder regenerante a la piel, fortaleciendo el manto hidrolipídico y preparándola para el estrés diario, de manera que su uso continuado ayuda a regular y evitar la aparición de flacidez y signos de envejecimiento. De rápida absorción. Especialmente indicado para pieles secas.

#### Argan oil and aloe vera

*Its composition rich in argan and aloe vera oil provides softness, hydration and a great regenerating power to the skin, strengthening the hydrolipid mantle and preparing it for daily stress, so that its continued use helps to regulate and avoid appearance of flaccidity and signs of aging. Fast absorption. Especially suitable for dry skin.*



**Bastón de masaje vibratorio con luz roja MEDISANA**  
**Vibration massage stick and red light MEDISANA**

u.m.vta: 1  4

**REF.06590**





- Masaje de vibración agradable
- Posibilidad de configurar diferentes ángulos de masaje
- Incluye 5 accesorios de masaje intercambiables
- La luz roja y el calor también se pueden conectar
- 2 niveles de intensidad de masaje ajustable
- Diseño práctico para un cómodo auto-masaje

- *Pleasant vibration massage*
- *Possibility to set different angles of massage*
- *Includes 5 interchangeable massage accessories*
- *Red light and heat can also be connected*
- *2 levels of adjustable massage intensity*
- *Practical design for a comfortable self-massage*

## Líquido tratamiento vendas frías

### Cold bandage treatment liquid

u.m.vta: 1  6 

**REF.07012**

**RELAJANTE – REFRESCANTE – DESCONGESTIONANTE – ANTICELULÍTICO**  
De acción reductora. Principios activos vegetales e hipotérmicos  
**CONCENTRATE 1 x 3**

Mezcla: 1 parte de líquido vendas frías + 3 partes de agua  
Loción cosmética con principios activos vegetales (fucus, hiedra, aquifolium) e hipotérmicos que producen un enfriamiento local de la temperatura en la zona tratada durante un tiempo controlado.

#### MODO DE EMPLEO:

Mezclar una parte de la loción con 3 partes de agua y empapar las vendas en la mezcla, envolviendo con ellas la zona a tratar. Mantener de 30 a 45 minutos y no ducharse en 2 horas aproximadamente. Utilizar dos o tres veces por semana.

*RELAXING - REFRESHING - DECOARANT - ANTICELLULITE*  
*Reductive action Vegetable and Hypothermic active ingredients*  
**CONCENTRATE 1 x 3**

Mix: 1 part of liquid cold bandages + 3 parts of water  
Cosmetic lotion with active ingredients vegetables (fucus, ivy, aquifolium) and hypothermic that produce a local cooling of the temperature in the treated area during a controlled time.

#### HOW TO USE:

Mix a part of the lotion with 3 parts of water and soak the bandages in the mixture, wrapping with them the area to be treated. Keep 30 to 45 minutes and do not shower in about 2 hours. Use two or three times a week



## Rollo vendas frías 15x10 crepé

### Roll cool bandage crimp 15x10

u.m.vta: 1  50

**REF.07108**



Confeccionadas en tela de crepé guesa y elástica para tratamientos de vendas frías y tratamientos de compresión. Empapa las vendas en el líquido de vendas frías (07012) para hacer un tratamiento anticelulítico, antiinflamatorio, etc.

*Made of thick and elastic crepe fabric for cold bandage treatments and compression treatments. Soak the bandages in the cold bandage liquid (07012) to make an anti-cellulite, anti-inflammatory treatment, etc.*

## Rollo vendas frías 10x10 crepé

### Roll cool bandage crimp 10x10

u.m.vta: 1  65

**REF.03041**



Vendaje elástico tanto longitudinal como transversal. Composición: algodón: 93,84%, elastómero revestido: 6,2%. Calidad superior. Vendaje de cadena tejida en los laterales, ideal para tratamientos corporales.

*Elastic bandage both longitudinal and transverse. Composition: cotton: 93.84%, coated elastomer: 6.2%. Superior quality. Bandage of chain knit on the sides, ideal for body treatments.*





**Manopla de algodón**  
Cotton mitten

u.m.vta: 12  96

    
**REF.01916**





**Manopla de crin**  
Sisal glove

u.m.vta: 1  20 

**REF. 01084**





**Espanja de goma y colores para baño/masaje**  
Rubber sponge bath/massage colours

u.m.vta: 1  16 

**REF. 04591**



- Doble tipo de púas.
- Ideal para la circulación, celulitis, pieles sensibles.
- Larga duración, no acumula pelos y necesita poco jabón.
- Double type of picks.
- Ideal for circulation, cellulite, sensitive hemorrhoids.
- Long lasting, does not accumulate hair and needs little soap

u.m.vta: 1  24 

**REF. 04590**





**Cepillo para el baño**  
Bath brush

u.m.vta: 1  12 

**REF. 00526**

- Fibra natural. Mando madera
- Natural fiber. Wood handle

u.m.vta: 1  15 

**REF. 00679**

- Púas de nylon
- Nylon hair



03

## Depilación Hair removal



*Cera kg, cera roll-on, fusor de cera,  
accesorios, pinzas depilar...*

*Wax kg, wax roll-on, wax heaters,  
accessories, hair removal, tweezers...*





## Bolsa de 1 Kg de Cera en perlas 1 kg bag of wax pearls

u.m.vta: 1  6 

Perlas Cera Miel  
Honey Wax Pearls

REF.07465

Perlas Cera rosa - Piel sensibles  
Pink Wax Pearls- Sensitive skins

REF.07466

Perlas Cera verde - Aloe Vera  
Green Wax Pearls- Aloe Vera

REF.07467

Perlas Cera Azuleno  
Azulene Wax Pearls

REF.07468



Fundir la cera en un fusor. Mezclar bien hasta conseguir una cera suave y homogénea.

Antes de aplicar, comprobar que la temperatura de la cera sea óptima. Aplicar con una espátula de madera o metálica una capa de cera en la misma dirección del crecimiento del vello. No dejar enfriar del todo y retirar a contrapelo con un tirón para lograr extraerlo de raíz.

- Eficaz en vello corto
- Con ingredientes naturales
- Depilación perfecta y duraderas
- No usar bandas

Melt the wax in a melter. Mix well until it is smooth and homogeneous.

Before applying, check that the temperature of the wax is optimal. With a wooden or metal spatula, apply a layer of wax in the same direction as the hair growth. Do not cool entirely and pull against the hair with a tug to remove it from the root.

- Effective on short hair.
- Made with natural ingredients
- Perfect and long-lasting hair removal
- Do not use bands

## Bolsa 1 Kg discos de cera

### Bag 1 Kg wax discs

u.m.vta: 1



6



REF.04675

- Discos de cera **Brasilian**
- Bidireccional
- Extra flexible
- No necesita papel bandas

- **Brazilian** wax discs
- Bidirectional
- Extra-flexible
- Does not need paper bands

REF. 03916

Miel  
Honey

REF. 03917

Piel sensibles  
con dióxido de  
titanio  
*Sensitive skin  
with titanium  
dioxide*

REF. 03918

Aloe Vera  
Aloe Vera

REF. 03919

Aceite de argán  
Argan oil

REF. 03920

Cacao  
Cocoa

REF. 04260

Azuleno  
Azulene

1 kg



La depilación con ceras de baja fusión es muy efectiva en la extracción del vello. Su especial formulación a base de cera natural de abeja y colofonias de altísima calidad, prepara la piel ablandando el poro. Su adherencia es total por lo que extrae el vello desde la raíz, retrasando así su aparición. Para obtener una consistencia elástica y cremosa a temperatura ambiente, algunas de nuestras ceras están elaboradas con dióxido de titanio. De este modo, conseguimos un punto de fusión más bajo que favorece la depilación. Precios escalados combinables a partir de la caja de 6 unidades de todas las referencias de la página 612 excepto al referencia 04675.

*Hair removal with low temperature melting waxes is very effective in hair removal. Its special formulation based on natural wax of bee and high quality rosin prepares the skin by softening the pore. Its adhesion is total so it extracts the hair from the root, thus delaying its appearance. To obtain an elastic and creamy consistency at ambient temperature, some of our waxes are made with titanium dioxide. In this way, we achieve a lower melting point that favors hair removal. Combinable scaled prices starting from the box of 6 units with all the references on page 612 except reference 04675.*



## Bolsa 1 kg cera made in Spain Bag 1 kg wax made in Spain

Zona de tratamiento: ingles, axilas, brazos, labio superior, facial, corporal. Escoge la que mejor se adapte en función de su elasticidad, al tipo de vello y piel: transparentes, elásticas, con color, perfumadas, baja fusión, etc. Precio escalado combinable con cualquiera de la referencia de la página 613-614.

*Treatment area: goin, underarms, arms, superior lip, facial, body. Choose the one that adapts best according to its elasticity, to the type of hair and skin: transparent, elastic, with color, perfumed, low melt, etc. Scaled price combinable with any of the reference on page 613-614.*



## Pastillas cera rosa - elasticidad doble superior Pink wax tablets - superior double elasticity

u.m.vta: 1 12

1 kg

REF.06323

Flexibles, permiten aplicar una fina capa reduciendo la sensación de calor. La cera clásica, especial para depilar ingles y axilas.

*Flexible, it allows to apply a thin layer reducing the sensation of heat. The classic wax, special for shaving goins and underarms.*



## Pastillas cera verde - elasticidad superior Green wax tablets - superior elasticity

u.m.vta: 1 12

REF.06324

Transparentes o semitransparentes, de textura fluida, fuerte arranque y rápido secado. Ligera y cristalina apta para cualquier zona del cuerpo.

*Transparent or semitransparent, fluid texture, strong start and rapid drying. Light and crystalline suitable for any area of the body.*



## Pastillas cera azul - elasticidad superior Blue wax tablets - superior elasticity

u.m.vta: 1 12

REF.06325

Transparentes o semitransparentes, de textura fluida, fuerte arranque y rápido secado. Ligera y cristalina apta para cualquier zona del cuerpo.

*Transparent or semitransparent, fluid texture, strong start and rapid drying. Light and crystalline suitable for any area of the body.*



**Bolsa 1 kg cera made in Spain**  
**Bag 1 kg wax made in Spain**



Zona de tratamiento: ingles, axilas, brazos, labio superior, facial, corporal. Escoge la que mejor se adapte en función de su elasticidad, al tipo de vello y piel: transparentes, elásticas, con color, perfumadas, baja fusión, etc.  
 Precio escalado combinable con cualquiera de la referencia de la página 613-614.

*Treatment area: groin, underarms, arms, superior lip, facial, body. Choose the one that adapts best according to its elasticity, to the type of hair and skin: transparent, elastic, with color, perfumed, low melt, etc.  
 Scaled price combinable with any of the reference on page 613-614.*

**Pastillas cera chocolate - elasticidad triple superior**  
**Chocolate wax tablets - superior triple elasticity**

u.m.vta: 1 12

1 kg

**REF.06328**

Flexibles y elásticas, favorecen la aplicación y retirada de forma suave y poco agresiva para la piel. Depilación suave, deja la piel ligeramente perfumada.

*Flexible and elastic, they favor the application and removal of soft and less aggressive for the skin. Smooth hair removal, leaves the skin slightly perfumed.*



**Pastillas cera vino - elasticidad triple superior**  
**Wine wax tablets - superior triple elasticity**

u.m.vta: 1 12

1 kg

**REF.06327**



Flexibles y elásticas, favorecen la aplicación y retirada de forma suave y poco agresiva para la piel. De intenso color, proporciona una depilación suave dejando la piel ligeramente perfumada.

*Flexible and elastic, they favor the application and removal of soft and little aggressive for the skin. Of intense color, it provides a smooth depilation leaving the skin slightly perfumed.*



## Caja 20 discos cera

### Box 20 wax discs

u.m.vta: 1	 24	
------------	--	---

**REF. 04070**

Aloe vera  
Aloe vera

**REF. 04071**

Miel  
Honey

**REF. 04072**

Piel sensible  
Sensitive skin



La depilación con ceras de baja fusión es muy efectiva en la extracción del vello. Su especial formulación a base de cera natural de abeja y colofonias de altísima calidad prepara la piel ablandando el poro. Su adherencia es total por lo que extrae el vello desde la raíz, retrasando así su aparición. Para obtener una consistencia elástica y cremosa a temperatura ambiente, algunas de nuestras ceras están elaboradas con dióxido de titanio. De este modo, conseguimos un punto de fusión más bajo que favorece la depilación. Precio escalado combinable con página 615.

*Hair removal with low temperature melting waxes is very effective in hair removal. Its special formulation based on natural wax of bee and high quality rosin prepares the skin by softening the pore. Its adhesion is total so it extracts the hair from the root, thus delaying its appearance. To obtain an elastic and creamy consistency at ambient temperature, some of our waxes are made with titanium dioxide. In this way, we achieve a lower melting point that favors hair removal. Scalable price combinable with page 615.*

**Cera bandeja**  
**Wax tray**

u.m.vta: 1  12 

Miel  
Honey

500 g

REF. 03722

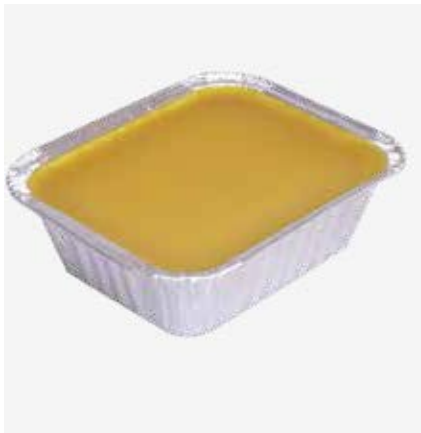

Clorofila  
Chlorophyl

500 g

REF. 03726



**Cera lata**  
**Wax tin**

u.m.vta: 1  24

Piel sensible  
Sensitive skin

REF.04563



Miel  
Honey

REF.03728



Aloe Vera  
Aloe Vera

REF.04735



u.m.vta: 1  12

Piel sensible  
Sensitive skin

REF.04565



Miel  
Honey

REF.04564



Aloe Vera  
Aloe Vera

REF.04736





400 ml



800 ml



## Fusores cera Wax heaters

u.m.vta: 1		12	
------------	---	----	---

REF. 03321



- Potencia: 110W
- Con termostato
- Sin cazoleta
- Apto para latas de 400 y 500 g
- Power: 110W
- With thermostat
- Without basket
- Suitable for cans of 400 and 500 g

u.m.vta: 1		60
------------	---	----

REF. RE03321/02

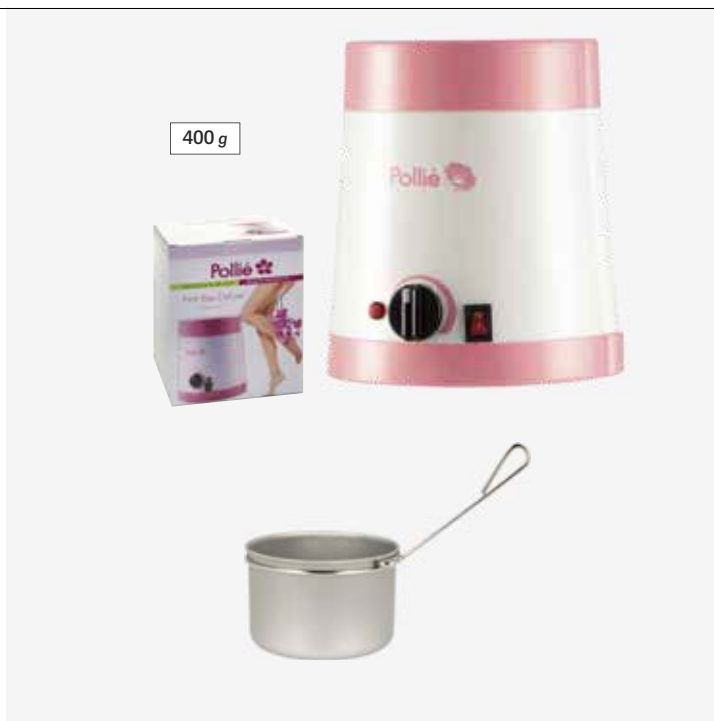
**Recambios**  
Spare parts



u.m.vta: 1		12	
------------	---	----	---

REF. 03322

- Potencia: 175W
- Con termostato
- Incluye cazoleta de 800 g
- Rápido calentamiento de la cera
- Seguro y ergonómico
- Ligero y de reducidas dimensiones
- Para discos, cera o perlas, utilizar cazoleta
- Power: 175W
- With thermostat
- With 800 g basket
- Fast heating of the wax
- Safe and ergonomic
- Lightweight and of reduced dimensions
- For discs, wax or pearls, use bowl

u.m.vta: 1		60
------------	---	----

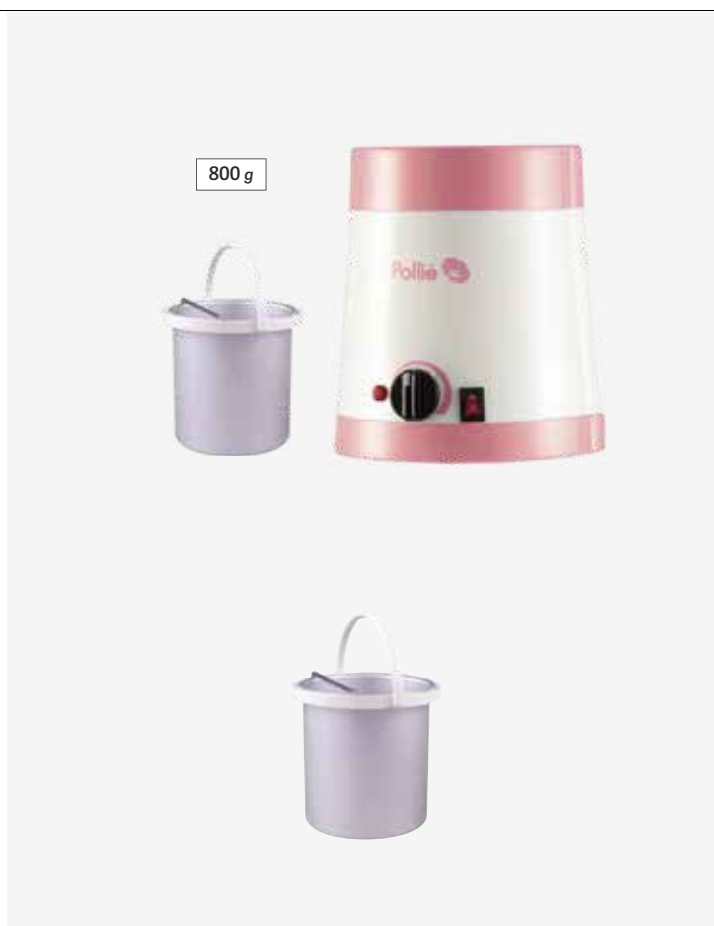

REF. RE03322/01

**Recambios**  
Spare parts





### Fusores cera Wax heaters

u.m.vta: 1		12	
------------	---	----	---

REF. 03154

- Potencia: 80W
- Con termostato
- Con cazoleta incluida de 450 g

- Power: 80W
- With thermostat
- With basket included 450 g



### Protector fusor cera Wax heater protector

u.m.vta: 1		16
------------	---	----



REF. 03716

- Bolsa 100 círculos protector fusor cera
- Diámetro interior: 9,8cm
- Diámetro exterior: 16cm
- Diámetro interior máximo: 13,5cm

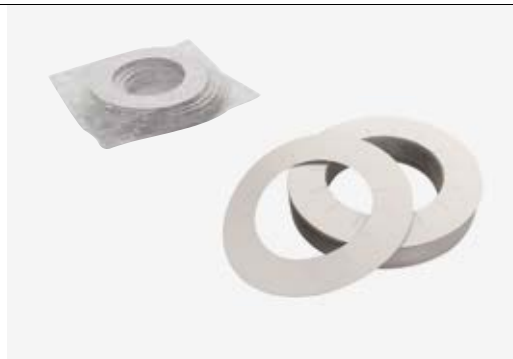
- Bag 100 rings wax protector heater
- Inside diameter: 9,8 cm
- Outside diameter: 16 cm
- Maximum inside dia meter: 13,5 cm



### Fusores cera Wax heaters

u.m.vta: 1		12	
------------	---	----	---

REF. 03612

- Potencia: 90W
- Termostato electrónico de temperatura
- Depósito de aluminio
- Rápido calentamiento de la cera
- Seguro y ergonómico
- Ligero y de reducidas dimensiones
- Cazoleta incluida con asa extraíble

- Power: 90W
- Electronic thermostat for temperature
- Aluminium reservoir
- Quickly warms wax to the desired temperature
- Safe and ergonomic
- Compact and lightweight
- Includes a bowl with a removable handle

u.m.vta: 1		1
------------	---	---

250 g



REF. RE03612/01

### Recambios Spare parts



## Fusores cera Pollié

### Polié wax heaters

u.m.vta: 1	 12	
------------	--	---



REF. 06614/58



REF. 06614/70



- Potencia: 40W
- Fusor cera 125 ml. Compacto ideal para la depilación de zonas pequeñas, tales como nariz, orejas, cejas y contorno barba

- Power: 40W
- Fusor wax 125 ml. Compact ideal for hair removal of small areas, such as nose, ears, eyebrows and beard contour

125 ml

REF. RE06614/01



### Recambios · Spare parts

- Cazoleta cera para los fusores
- ref. 06614/58, 06614/70 y 04505
- Wax bowl for heaters
- ref. 06614/58, 06614/70 and 04505

### Fusores cera con termostato de metal

#### Wax heaters with metal thermostat

Ideal para utilizar con discos de cera o pastillas  
Ideal for use with wax discs or tablets

u.m.vta: 1  1

250 g

REF. 02905

- Potencia: 125W
- Con filtro
- Power: 125W
- With filter



400 g

REF. 02928

- Potencia: 125W
- Con filtro
- Apto para latas de 400 y 500 g
- Power: 125W
- With filter
- Suitable for cans of 400 and 500 g



1 kg

REF. 02908

- Potencia: 250W
- Con filtro
- Power: 250W
- With filter



4 kg

REF. 02900

- Potencia: 450W
- Con filtro
- Power: 450W
- With filter



## FUSORES GRANDES BIG WAX HEATERS

### Fusores cera con termostato de metal Wax heaters with metal thermostat

Ideal para utilizar con discos de cera o pastillas  
Ideal for use with wax discs or tablets

u.m.vta: 1  1

10 kg

REF. 07821

- Potencia: 2 x 450W
- Con filtro
- Power: 2 x450W
- With filter



12 kg

REF. 04216

- Potencia: 2 x 450W
- Con filtro
- Power: 2 x450W
- With filter



20 kg

REF. 04217

- Potencia: 2 x 450W
- Con filtro
- Power: 2 x450W
- With filter



Fusores de cera con 2 recipientes conectados y con filtro para filtrar cera reutilizable. Contiene 2 termostatos independientes para cada recipiente

Wax heaters with 2 connected pots and equipped with a filter which allows to reuse the wax. It contains 2 independent thermostats for each container

### Espátula cera madera

#### Wooden wax spatula

u.m.vta: 12  12

Mini Pequeña  
Mini Small  
**REF.01627** **REF.01628**

**REF.01630** Mediana  
Medium



**REF.01632** Grande  
Large

**REF.01634** Súper grande  
Extra large



### Caja 100 espátulas madera

#### Box 100 wooden spatulas

u.m.vta: 1  50 



**REF.03282**

**REF.07114**



### Bolsa 100 espátulas madera

#### Bag 100 wooden spatulas

u.m.vta: 1  100 

**REF.06651**







**Paquete 100 espátulas cera especial**  
**Pack 100 special wax spatulas**

u.m.vta: 1  50

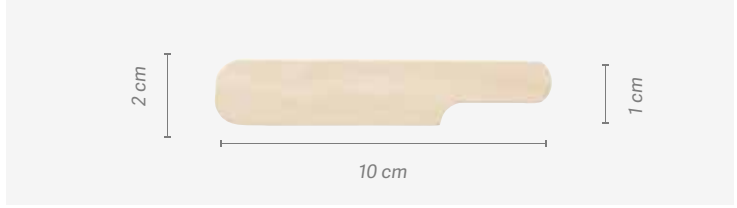
**REF.01636**



**Espátula cera con mango**  
**Wax spatula with handle**

u.m.vta: 12  12

**REF.01629**



**REF.01631**

**REF.01633**

**Espátula Extra Flex**  
**Extra flex spatula**

u.m.vta: 1  24 

**REF.03229**



Color blanco. Material plástico rígido para cera o cualquier tipo de tratamiento de estética que lo precise  
 White color. Rigid plastic material for wax or any type of aesthetic treatment that requires it

**REF.03230**

Color blanco. Material plástico flexible  
 White color. flexible plastic material.



**Espátula cera metálica/madera**  
**Metal/wood wax spatula**

u.m.vta: 1  12 



**REF.03469**

**REF.01419**



## Roll-on cera made in Spain

### Roll-on for wax made in Spain

u.m.vta: 20  20 

Zona de tratamiento: axilas, pecho, espalda, brazos, abdomen, piernas, rostro e ingles (roll-on facial). Escoge la que mejor se adapte al tipo de vello y piel: transparentes, ultra cremosas, con color, perfumadas, etc. Precios escalados combinables página 624-625.

Treatment area: underarms, chest, back, arms, abdomen, legs, face and groin (roll-on facial). Choose the one that best suits the type of hair and skin: transparent, ultracreamy, with color, perfumed, etc. Combinable scaled prices page 624-625.



## Natural - cristalina

### Natural - crystalline

**REF.06317**

Transparentes o semitransparentes, de textura fluida y fuerte arranque. Su excelente combinación de resinas de pino la hacen idónea para una perfecta depilación.

*Transparent or semitransparent, fluid texture and strong start. Its excellent combination of pine tree resins make it ideal for a perfect hair removal.*

## Azul- cristalina

### Blue - crystalline

**REF.06318**

Transparentes o semitransparentes, de textura fluida y fuerte arranque. Apto para todas las zonas incluso las más sensibles.

*Transparent or semitransparent, fluid texture and strong start. Suitable for all areas, even the most sensitive.*

## Oro - pigmentos irisados

### Gold - irised pigments

**REF.06321**

Densa textura que favorece la adherencia y reduce la sensación de calor y dolor. Gracias a las partículas doradas la cera mantiene su temperatura facilitando la aplicación y el arranque.

*Dense texture that promotes adhesion and reduces the sensation of heat and pain. Thanks to the golden particles the wax maintains its temperature facilitating the application and the pull up.*



110 g

### Rosa - cremosa

#### Pink - creamy

110 g

REF.06319

Transparentes o semitransparentes, de textura fluida y fuerte arranque. Su textura elástica facilita la depilación en cualquier tipo de vello.

*Pleasantly creamy and elastic texture for a perfect start. Its elastic texture helps to hair removal in any type of hair.*

### Chocolate - cremosa

#### Chocolate - creamy

REF.06320

De agradable textura cremosa y elástica para un perfecto arranque. Para una depilación suave y eficaz, con un intenso aroma a chocolate.

*Pleasantly creamy and elastic texture for a perfect start. For a smooth and effective hair removal, with an intense chocolate aroma.*

### Vino - cremosa

#### Wine - creamy

110 g

REF.06322

De agradable textura cremosa y elástica para un perfecto arranque. Para una depilación suave y eficaz, dejando la piel ligeramente perfumada.

*Pleasantly creamy and elastic texture for a perfect start. For a smooth and effective hair removal, leaving the skin slightly perfumed.*

110 g



**Roll-on cera****Roll-on wax**

u.m.vta: 24



24



El sistema de depilación roll-on es óptimo para aquellos profesionales que buscan conseguir los mejores resultados. Las resinas con las que fabricamos las ceras pueden utilizarse a mayor temperatura que la cera de baja fusión, con la ventaja que se aplican mediante una tira más fina. Así, la cera se enfría casi al instante y la sensación de calor en la piel se minimiza. La cera se retira fácilmente con las bandas higiénicas. Precios escalados combinables página 626-627 excepto referencia 03907.

*The roll-on hair removal system is optimal for those professionals who want to achieve the best results. The resins with which we make the waxes can be used at a higher temperature than the low melting wax, with the advantage that they are applied with a thinner strip. The wax cools almost instantly and the sensation of heat in the skin is minimized. Wax is easily removed with hair removal bands. Combinable scaled prices page 626-627 excepto reference 03907.*

Miel  
Honey

**REF.03704**

Talco con dióxido de titanio  
Talc with titanium dioxide

**REF.03705**

100 ml



Aceite de oliva  
Olive oil wax

**REF.03739**

Aloe vera  
Aloe vera

**REF.03740**

Para hombre  
For man

**REF.03858**

Azuleno  
Azulene

**REF.04259**



Coco  
Coconut  
**REF.04678**

Manzana  
Apple wax  
**REF.04674**

Banana  
Banana  
**REF.04677**

Cacao  
Cacao  
**REF.03748**

Argán  
Argan wax

**REF.03706**

Rosa pieles sensibles  
con dióxido de titanio  
Pink sensitive skin with  
titanium dioxide

**REF.03749**

Facial  
Facial



24 u

**REF.03907**



### Calentador roll-on con termostato interior

#### Roll-on heater with internal thermostat

u.m.vta: 1  30 

**REF. 03379**

- Potencia: 15W
- Calentador de cera roll-on con visor lateral del nivel de cera
- Diseño ergonómico
- Rápido en alcanzar la temperatura óptima
- Gracias a su diseño interior se adapta a cualquier tipo de roll-on
- Termostato interno que mantiene la temperatura ideal para la aplicación de la cera
- Led indicador de encendido y apagado
- 100-240V~
- 50/60 Hz

- Power: 15W
- Roll-on wax warmer with a side opening to check wax levels
- Ergonomic design
- Quickly reaches optimal temperature
- Its interior design allows it to adapt to all types of roll-on devices
- Its internal thermostat keeps it at the ideal temperature to apply wax
- On / off LED
- 100-240V~
- 50/60Hz



### Base calentador roll-on ref. 03379

#### Support roll-on ref. 03379

u.m.vta: 1  27

1 roll-on

**REF. 03272**

- Potencia: 15W
- 100-240V~

- Power: 15W
- 100-240V~

u.m.vta: 1  18

2 roll-on

**REF. 03273**

- Potencia: 30W
- 100-240V~

- Power: 30W
- 100-240V~

u.m.vta: 1  13

3 roll-on



**REF. 03274**

- Potencia: 45W
- 100-240V~

- Power: 45W
- 100-240V~



## Calentador roll-on con termostato exterior Roll-on heater with external thermostat

u.m.vta: 1  9 



**REF. 04091**

- Potencia: 20W
- Calentador con base para mayor estabilidad y uso
- Ventana para visionar el nivel de la cera
- Regulación de la temperatura del 1 al 6
- Cable de la base 2 metros
- Rápido calentamiento y bajo consumo
- Tapa protectora
- Gracias a su diseño interior se adapta a cualquier tipo de roll-on
- Led indicador de calentamiento
- 100-240V~

- Power: 20W
- Heater with a base for increased stability and ease of use
- Window to check wax levels
- Temperature regulation from 1 to 6
- The cable of the base is 2 meters
- Rapid heating and low energy consumption
- Protective lid
- Its interior design allows it to adapt to all types of roll-on devices
- LED to indicate heat level
- 100-240V~



## 1 calentador roll-on + 1 base cargador con base magnética 1 roll-on heater + 1 charger base with magnet base

u.m.vta: 1  6 

**REF. 06623**





- Potencia: 20W
- Capacidad: 100 g
- Frecuencia: 50Hz
- Voltaje: 220-240V~
- Base conectable a otras bases (hasta 5 bases)
- Ventana lateral para ver nivel cera
- Control regulador de temperatura (85°C máx)
- Ligero y de reducidas dimensiones
- Con tapón protector

- Power: 20W
- Capacity: 100 g
- Frequency: 50Hz
- Voltage: 220-240V~
- Connect the base to others (up to 5)
- Side window to see the wax level
- Temperature regulator control (85°C max)
- Lightweight and small size
- With protective cap



## Kits de depilación Pollié

### Polié waxing kits

u.m.vta: 1  10 

**REF.03310**

#### Contiene · It contains



- 1 calentador roll-on 15W
- 1 roll-on argán
- 1 paquete de 20 tiras depilar
- 3 toallitas de aceite post-depilación

- 1 roll-on heater 15W
- 1 roll-on argan
- 1 pack of 20 hair removal strips
- 3 post-waxing oil towels



Los kits de depilación Pollié son ideales para una depilación fácil y cómoda con todo lo necesario para depilarte en casa de forma profesional. Luce unas piernas bonitas todo el año.

*Polié waxing kits are ideal for quick, comfortable waxing, and they include everything you need to wax yourself professionally from the comfort of your own home, ensuring that you have beautiful legs year-round.*

u.m.vta: 1  9 

**REF.03925**

#### Contiene · It contains

- 1 calentador roll-on 20W
- 1 roll-on argán
- 1 paquete de 20 tiras depilar
- 3 toallitas de aceite post-depilación

- 1 roll-on heater 20W
- 1 roll-on argan
- 1 pack of 20 hair removal strips
- 3 post-waxing oil towels





**Paquetes tiras papel depilación POLLIE**  
**Pack strips hair removal POLLIE**

u.m.vta: 100 100

**85 g/m<sup>2</sup>**  
**REF.02091**

- 20 tiras
- 20 strips

u.m.vta: 25 25

**80 g/m<sup>2</sup>**  
**REF. 00929**

- 100 tiras
- 100 strips

u.m.vta: 25 25

**90 g/m<sup>2</sup>**  
**REF. 02556**

- 100 tiras
- Extra fuerte
- 100 strips
- Super strong



u.m.vta: 50 50

**REF. 04207**

- 100 tiras
- 100 strips

**REF. 03804**



- 100 tiras
- 100 strips





## Rollo papel depilar

### Hair removal paper roll

u.m.vta: 1  12 



80 g/m<sup>2</sup>

REF. 06926

- Ancho: 7 cm
- Largo: 75 m

- Width: 7 cm
- Length: 75 m



u.m.vta: 1  12 

80 g/m<sup>2</sup>

REF. 03806



- Ancho: 7 cm
- Largo: 100 m

- Width: 7 cm
- Length: 100 m



## Paquete tiras papel depilación ANÓNIMAS

### Pack strips hair removal paper UNPRINTED

u.m.vta: 100  100 

80 g/m<sup>2</sup>

REF. 00929/00

100 tiras  
100 strips

90 g/m<sup>2</sup>

REF. 02556/00

100 tiras  
Extra fuerte  
100 strips  
Super strong

80 g/m<sup>2</sup>

REF.03805

10 tiras  
10 strips

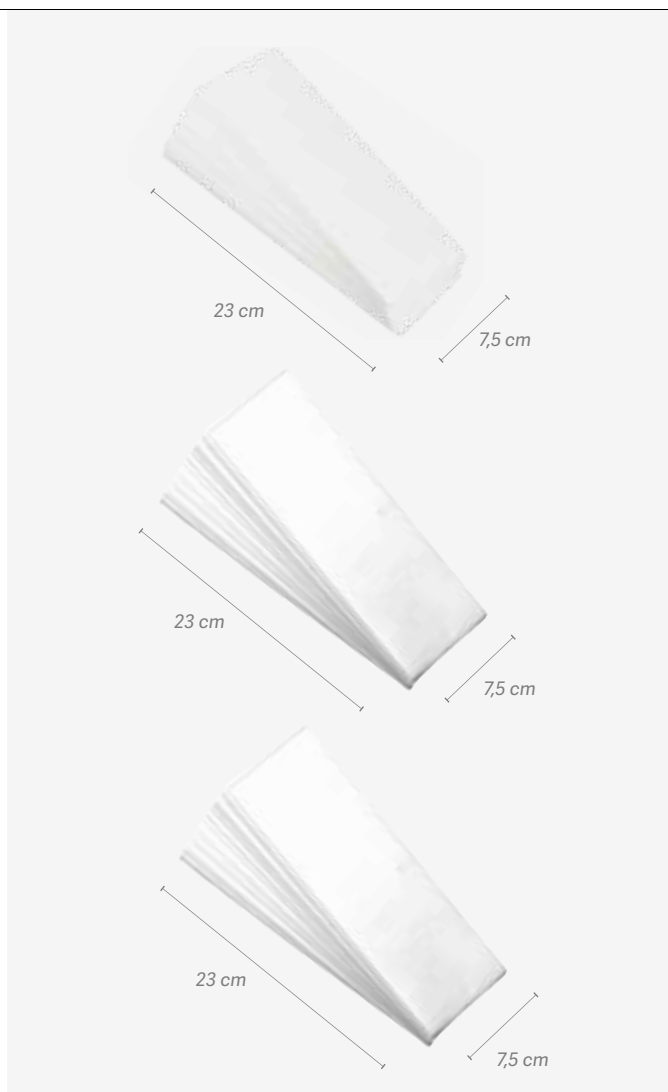

**Caja de 100 tiras papel depilación 90 gramos hipoalergénico**  
**Box 100 strips 90 grams hypoallergenic hair removal paper**

u.m.vta: 1  28 

90 g/m<sup>2</sup>

REF. 06114



Extra: al tener más densidad es más fuerte y resistente

Fibras estrechamente entrelazadas que dan al producto una resistencia total al desgarre y actúan como barrera para que la cera no traspase.

*Stronger and more resistant due to its thickness*

*Entwined closely fibers for a total resistance to laceration creating a barrier that avoids wax penetration*

**Toallitas aceite post depilación**  
**Post hair removal oil wipes**

u.m.vta: 12  12

Bolsa de 5 toallitas  
 Bag 5 wipes

2 ml

REF.03855

u.m.vta: 500  500

A ganel  
 In Bulk

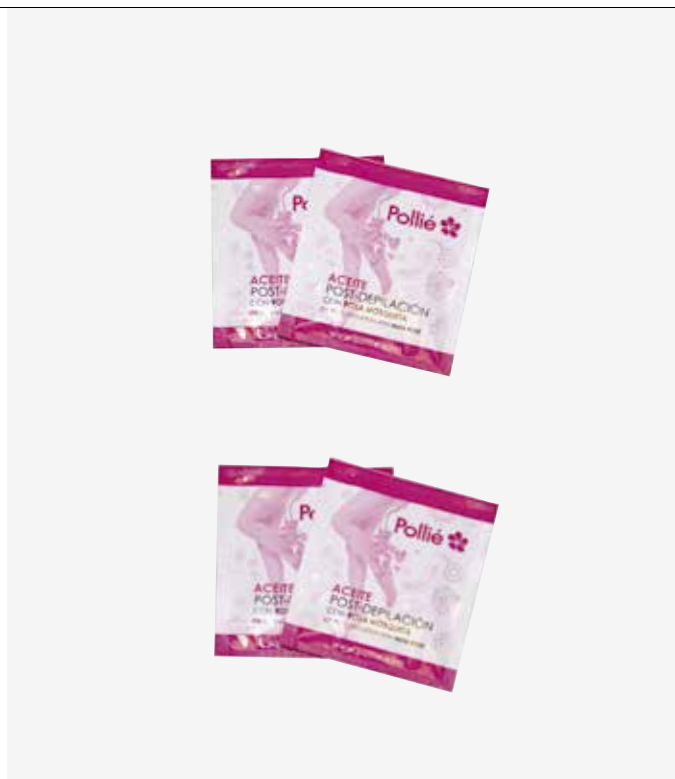

2 ml

REF.03855/01



## Gel post depilación Aloe Vera

### Post hair removal Aloe vera gel

u.m.vta: 1  6 

500 ml

REF.07644

Ideal para después de cualquier tipo de depilación incluida la láser por su acción regeneradora y cicatrizante. Todo tipo de Piel.

- Suavizante e Hidratante
- Regeneradora
- Cicatrizante

*Ideal for after any type of hair removal, including laser hair removal, due to its regenerating and healing action. All skin types.*

- Smoothing and Moisturizing
- Regenerator
- Healing

## Aloe Vera con caléndula

### Aloe Vera with calendula

500 ml

REF.07645

Ideal para después de cualquier tipo de depilación incluida la láser por su acción regeneradora y cicatrizante. Propiedades anti-inflamatorias y antisépticas. Todo tipo de Piel.

- Hidratante
- Regenerante
- Cicatrizante
- Acción Anti-Inflamatoria - Antiséptica.

*Ideal for after any type of hair removal, including laser hair removal, due to its regenerating and healing action. Anti-inflammatory and antiseptic properties. All skin types.*

- Moisturizing
- regenerating
- Healing
- Anti-Inflammatory Action - Antiseptic.

## Inhibidor Vello

### Hair inhibitor

500 ml

REF.07646

Ralentiza el crecimiento del vello y hace que este crezca mas débil. Posee propiedades hidratantes. Todo tipo de pieles.

- Ralentiza el crecimiento del vello.
- Debilita el nuevo vello.
- Hidratante.



*It slows down hair growth and makes it grow weaker. It has moisturizing properties. All skin types.*

- Slows hair growth.
- It weakens the new hair.
- Moisturizing.

NEW



**Gel post depilación**  
**Post hair removal gel**

u.m.vta: 1  6 



500 ml

- 99% aloe vera
- 99% aloe vera

REF.03613



**Aceite post depilación**  
**Post hair removal oil**

u.m.vta: 1  6 

500 ml

- Con rosa mosqueta
- Aroma a rosas

REF.03614



**Caja 20 bandas de cera fría PIELES SENSIBLES**  
**Box 20 cold wax strips SENSITIVE SKIN**

u.m.vta: 1  30

REF.03717

Bandas corporales  
Body strips

u.m.vta: 1  40

REF.03718

Bandas faciales  
Face strips



**Con extractos de frutos rojos**  
**With red fruit extracts**



### Caja 50 agujas depilación cónicas

#### Box 50 conic hair removal needles

u.m.vta: 1  20

TIPO K

0,5 mm **Inox**

REF.02965

TIPO K

1 mm **Inox**

REF.02966

TIPO K

1,5 mm **Inox**

REF.02967

TIPO K

0,5 mm **Oro-Gold**

REF.02968

TIPO K

1 mm **Oro-Gold**

REF.02969

TIPO K

1,5 mm **Oro-Gold**

REF.02970



### Agujas depil. Incl. Inclinadas

#### Hair removal angle needles

u.m.vta: 1  20

TIPO K

1 mm **Inox**



REF.03287

- Caja 50 agujas
- Box 50 needles



### Limpiador aparatos de cera

#### Wax cleaner

u.m.vta: 1  12 

500 ml

REF. 03437

- Disolvente en spray
- Para fusores y calentadores



- Spray solvent
- For fusers and heaters





### Gel electroconductor neutro

#### Neutral electroconductor gel

u.m.vta: 1		4	
------------	---	---	---

5 L

REF. 06694



El gel de transmisión de ultrasonidos TASSEL está indicado para mejorar la conductividad para ultrasonidos de diagnóstico y terapéutico. Es soluble al agua, no deja manchas. Se puede usar con todos los dispositivos de ultrasonidos disponibles en el mercado. Se extiende fácil, uniformemente y sin secarse.



El gel de transmisión de ultrasonidos TASSEL está destinado para uso externo en la piel intacta y sin heridas cutáneas. Aplique el gel en la zona a tratar. Es un excelente agente conductor para usos de terapia de ultrasonidos, imagen diagnóstica y depilación láser.

*The TASSEL ultrasound transmission gel is indicated to improve the conductivity for diagnostic and therapeutic ultrasound. It is soluble in water, does not leave stains. It can be used with all ultrasonic devices available in the market. It spreads easily, evenly and without drying out.*

*The TASSEL ultrasound transmission gel is intended for external use on intact skin and without skin wounds. Apply the gel to the area to be treated. It is an excellent conductive agent for ultrasonic therapy, diagnostic imaging and laser hair removal.*

### Gel electroconductor Aloe Vera



#### Aloe Vera Electroconductor gel

u.m.vta: 1		6	
------------	---	---	---

1 L

REF. 07616





u.m.vta: 1		1	
------------	---	---	---

5 L

REF. 07617

## Talco TASSEL

### TASSEL talcum

u.m.vta: 1  6 

200 g

REF. 06429

Polvos de talco extrafinos perfumados. Suavidad, frescura y nutrición para la piel. Los polvos de talco Tassel son suavizantes, hidratantes y emolientes.

Ideales para después del afeitado o depilación, irritaciones o escoqueduras, rojez, exposición al sol o lesiones dérmicas. Sin alérgenos y sin parabenos. Testado dermatológicamente.

- Absorbe la humedad
- Mantiene la piel fresca y seca
- Alivia la piel irritada
- Suaviza



*Extra-fine and perfumed talcum powder. Softness, freshness and nutrition for the skin. Tassel talcum powder softens, moisturises and hydrates. Ideal for after shaving or depilation, irritations or stings, redness, sun exposure or skin lesions. Does not contain any allergens or parabens. Tested dermatologically.*

- Absorbs moisture
- Keeps skin fresh and dry
- Relieves irritated skin
- Smooths



## Dispensador 100 maquinillas rasurar Pollié desechable

### Dispenser 100 Pollié disposable razors

u.m.vta: 1  20 

REF. 07440



NEW



Especialmente diseñada para el afeitado corporal. Con su hoja fabricada en acero sueco de alta calidad inoxidable y con un cabezal con peine, nos permite incluso rasurar aquellos pelos en las partes más delicadas. Ideal para la depilación láser. Es fácil de enjuagar y limpiar.

*Specially designed for body shaving. Its blade, made of high-quality Swedish stainless steel, and a comb head allows you to shave even the hair of the most delicate areas. Ideal for laser hair removal. Easy to rinse and clean.*

**Caja 100 navajas desechables Pollié**  
**Box 100 Pollié disposable razors**

u.m.vta: 1		7	
------------	---	---	---

**REF. 02480**



**Bolsa 5 maquinillas DERBY BODY**  
**Bag 5 DERBY BODY shaving razors**

u.m.vta: 14		112
-------------	---	-----

**REF.03828**

- Bolsa de 5 maquinillas de afeitado, con peine protector
  - Especialmente diseñada para eliminar pelos del cuerpo, ya que el peine protector especial proporciona un afeitado más fácil y seguro para los pelos más largos
  - Ideal para utilizar para el afeitado previo a la depilación láser
  - Recomendada en hospitales para afeitados previos a la cirugía
  - Cabezal y mango en material poliestireno
- 
- Bag of 5 razors with a protective comb
  - Specially designed to remove hair from the body, as the protective comb ensures an easier and safer shave for longer hairs
  - Ideal for shaving prior to laser waxing
  - Recommended in hospitals for shaving prior to surgery
  - The head and handle are made from polystyrene



**Bolsa 5 maquinillas DERBY 2**  
**Bag 5 DERBY 2 shaving razors**

u.m.vta: 40		40
-------------	---	----

Dos hojas  
 2 blades

**REF.02948**





**Pinzas depilar**  
**Hair removal tweezers**

Solingen

u.m.vta: 12 12

Nickel

**REF.01080** Punta testa  
Testa point



8 cm

**REF.00938** Punta testa  
Testa point



8 cm

**REF.00937** Punta testa  
Testa point



8 cm

**REF.01974** Punta testa  
Testa point



8 cm

**REF.00939** Punta testa  
Testa point



9 cm

**REF.01081** Punta testa  
Testa point



9 cm

**REF.00940** Punta testa  
Testa point



9 cm



**Pinzas depilar**  
**Hair removal tweezers**

Solingen

u.m.vta: 12 12

- REF.02467** Punta fina  
*Fine point*
  
- REF.02468** Punta oblicua  
*Oblique point*
  
- REF.02469** Punta plana  
*Flat point*

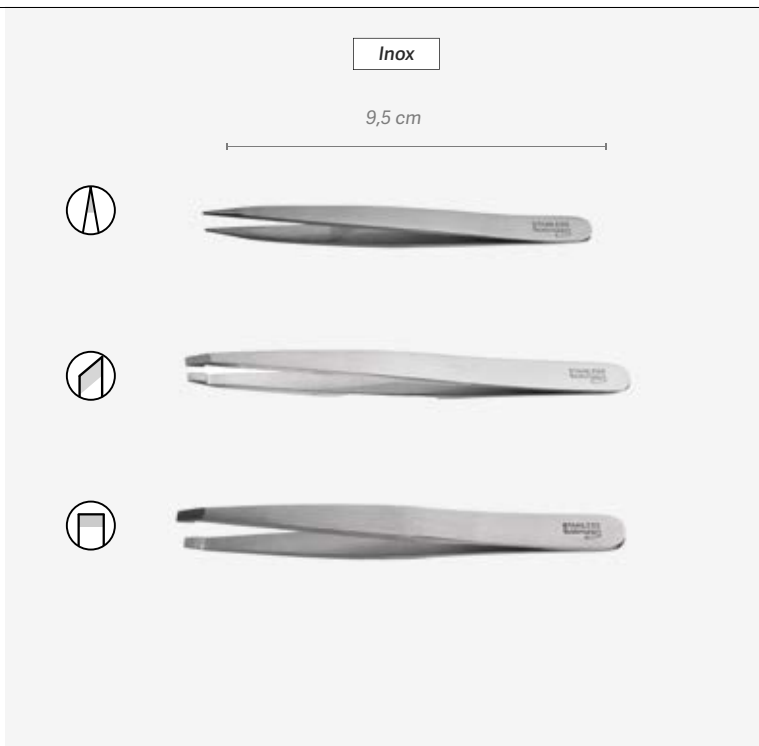

u.m.vta: 12 12

- REF.01402** Punta fina  
*Fine point*
  
- REF.01403** Punta fina  
*Fine point*
  
- REF.01404** Punta oblicua  
*Oblique point*
  
- REF.01405** Punta plana  
*Flat point*

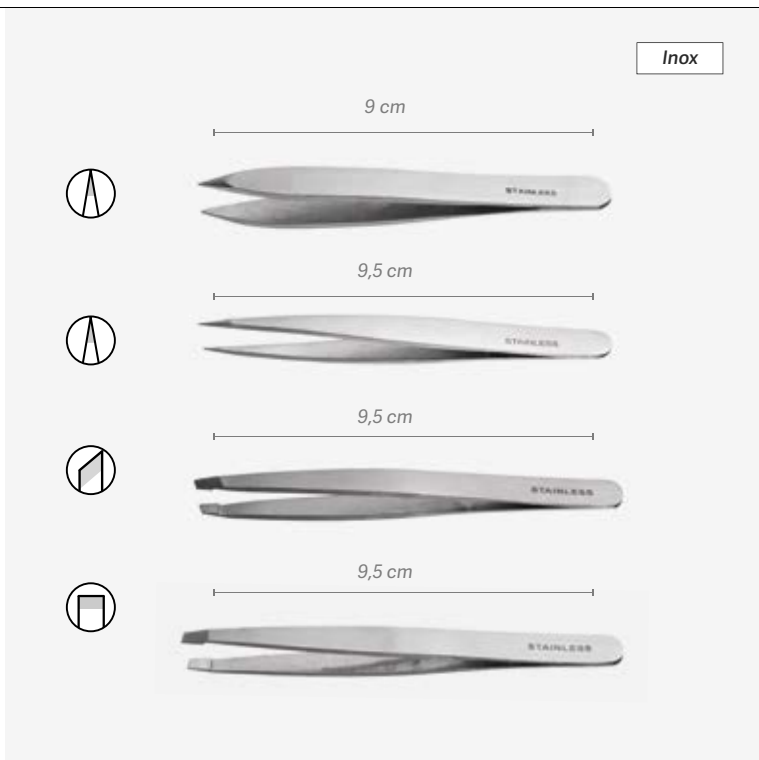



**Pinzas depilar POLLÍÉ**  
**POLLÍÉ hair removal tweezers**

u.m.vta: 12  12

**Punta testa**  
*Testa point*

**REF.03205**



**REF.02625**



**REF.02626**



**REF.02627**



**Punta plana**  
*Flat point*

**REF.01340**



**REF.01341**



**REF.01339**



**REF.02793**



**REF.02794**



**REF.02795**



**REF.02796**



**Punta oblicua**  
*Oblique point*

**REF.02628**



**Pinzas depilar ANATOMICAL**  
**ANATOMICAL hair removal tweezers**

u.m.vta: 12  12

**REF.02630** Punta oblicua  
*Oblique point*



9,5 cm

**REF.02500** Punta oblicua  
*Oblique point*



10 cm

**REF.02629** Punta plana  
*Flat point*



9,5 cm

**REF.02631** Punta fina  
*Fine point*



10 cm

**Pinzas depilar**  
**Hair removal tweezers**

**REF.02540/50** Punta oblicua  
*Oblique point*



9 cm

**REF.02742/50** Punta oblicua  
*Oblique point*



9,5 cm

**Pinzas depilar oblicua, colores**  
**Oblique hair removal tweezers, colours**

u.m.vta: 12  12

Punta oblicua  
 Oblique point



REF.02123



Punta oblicua  
 Oblique point



REF.02499

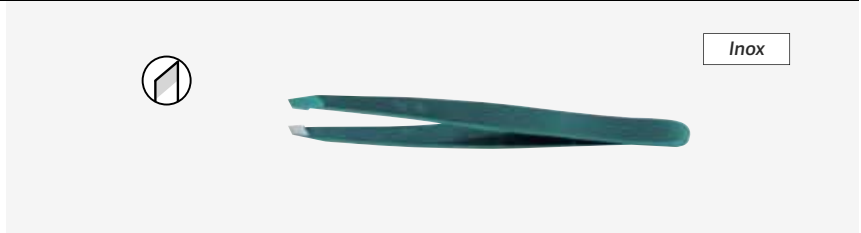

Punta oblicua  
 Oblique point

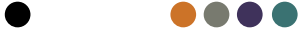

REF.02744/50

REF.02744



Punta oblicua  
 Oblique point



REF.02743/50

REF.02743



Punta oblicua  
 Oblique point



REF.02742/50

REF.02742

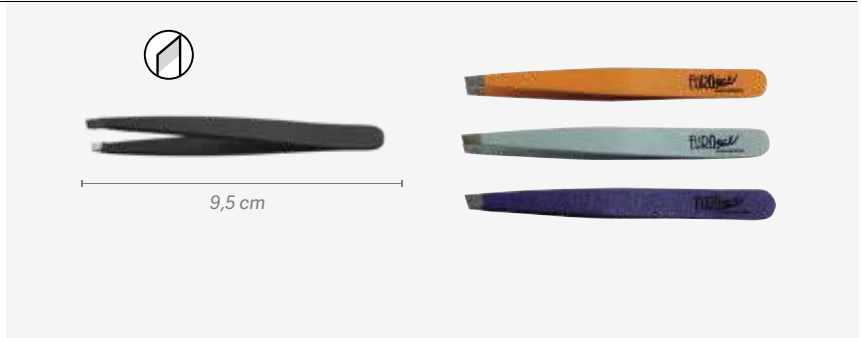

**Expositor 24 pinzas oblicuas color 9,5 cm**  
**Display 24 oblique tweezers colours 9,5 cm**

u.m.vta: 1  20

Punta oblicua  
 Oblique point

**REF.03723**



**Expositor 24 pinzas estampado animal 9,5 cm**  
**Display 24 animal print tweezers 9,5 cm**

u.m.vta: 1  20

Punta oblicua  
 Oblique point

**REF.03724**



**Expositor 24 pinzas negras 9cm**  
**Display 24 black tweezers 9 cm**

u.m.vta: 1  20

Punta oblicua  
 Oblique point

**REF.03725**



04

## Manicura y pedicura Manicure and pedicure

*Esmaltes de uñas, quitaesmalte, lámparas manicura,  
tornos de uñas, lupas, limas, alicates...*

*Nail polishes, removers, manicure lamps, nail drills,  
magnifying glass, nail files, nippers...*



## Esmalte Pollié · Pollié nail polish

**¿Cómo esmaltar? · How to polish nails?**

1. Aplicar una base para proteger la uña
2. Antes de aplicar el esmalte de color, es necesario mover un poco el contenido, aunque en ningún caso debes hacerlo agiténdolo de arriba hacia abajo, ya que esto provocará que la pintura pueda dejar pompas en tus uñas. Lo ideal es situar el frasco entre las manos y hacerlo rodar de forma horizontal. Cuando vayas a aplicar el esmalte sobre las uñas, es importante que lo hagas desde la mitad y lo extiendas de forma vertical
3. La aplicación se realizará con poca cantidad de esmalte en el pincel, y comenzando desde la cutícula hasta la punta de la uña. De abajo a arriba
4. Para que la duración del esmalte sea lo máximo posible hay que aplicar el Top Coat deseado sellando la punta
5. Para terminar, aplicar aceite para las cutículas y crema de manos

1. Apply a base to protect the nail
2. Before applying the color nail polish, it is necessary to move the contents a little, although in no case should you shake it from top to bottom, as this will may cause bubbles on your nails. The ideal is to place the bottle between your hands and make it roll horizontally. When you are going to apply the nail polish on the nails, it is important that you do it from the middle and extend it vertically
3. The application will be made with little amount of nail polish in the brush, and starting from the cuticle to the tip of the nail. From bottom to top
4. For the duration of the nail polish to be as long as possible, it is necessary to apply the desired Top Coat by sealing the tip
5. To finish, apply cuticles oil and hand cream

**Expositor esmalte de uñas POLLIÉ**  
**POLLIÉ nail polish display**
u.m.vta: 1  1

REF.03609

- 3 esmaltes x 33 colores = 99 esmaltes en total
- 1 carta de colores
- Expositor
- 1 póster

- 3 nail polish x 33 colours = 99 nail polishes
- Display
- 1 colours chart
- 1 Poster

**Esmaltes de uñas POLLIÉ**  
**POLLIÉ nail polishes**
u.m.vta: 3  3

12 ml

Blanco sólido  
Solid white

REF.03505

Blanco  
White

REF.03507

Blanco perla  
Pearl white

REF.03503

Hielo  
Ice

REF.03501



## Esmaltes de uñas POLLÍE

### POLLÍE nail polishes

u.m.vta: 3  3

12 ml

Beige  
Beige

REF.03497

Arena  
Sand

REF.03513

Rosa nude  
Nude pink

REF.07426

Súper nude  
Super nude

REF.07424

Camel  
Camel

REF.03422

Rosa pastel  
Pastel pink

REF.03495

Rosa nacarado  
Pearled pink

REF.03494

Rosa Candy  
Candy Pink

REF.04477

Rosa chicle  
Chewing pink

REF.03496

Rosa fucsia  
Pink fuchsia

REF.03504

Amaranto  
Amaranto

REF.04479

Terracota  
Terracote

REF.03423

Remolacha  
Beet

REF.06239

Coral  
Coral

REF.03510

Fresa  
Strawberry

REF.03511

Rojo pasión  
Passion red

REF.03502

Cereza  
Cherry

REF.07423



**Esmaltes de uñas POLLÍE**  
**POLLÍE nail polishes**

u.m.vta: 3  3

Rojo cereza  
 Cherry red

**REF.03490**



Rojo metalizado  
 Metallic red

**REF.04295**



Granate  
 Maroon

**REF.03493**



Chocolate  
 Chocolate

**REF.03491**



12 ml

Amarillo  
 Yellow

**REF.03859**



Dorado  
 Golden

**REF.04085**



Bronce  
 Bronze

**REF.03499**



Verde pastel  
 Pastel green

**REF.04227**



Verde esmeralda  
 Emerald green

**REF.03860**



Verde mar  
 Sea green

**REF.04569**



Verde aguamarina  
 Aquamarine green

**REF.04478**



Verde Jade  
 Jade green

**REF.04294**



Turquesa  
 Turquoise

**REF.03509**



Verde enebro  
 Juniper green

**REF.04570**



Verde bosque  
 Forest green

**REF.03420**



## Esmaltes de uñas POLLÍE

### POLLÍE nail polishes

12 ml

u.m.vta: 3  3

Verde selva  
Jungle green

REF.06240



Azul cyan  
Cyan blue

REF.03861



Turquesa metalizado  
Metallic turquoise

REF.04293



Azul metalizado  
Metallic blue

REF.03508



Azul Añil  
Indigo blue

REF.04567



Lila perlado  
Pearled lilac

REF.03506



Lila pastel  
Pastel lilac

REF.04226



Amatista  
Amethyst

REF.04568



Lila intenso  
Intense lilac

REF.07425



Violeta  
Violet

REF.03421



Berenjena  
Eggplant colour

REF.04082



Plata  
Silver

REF.04291



Gris mate  
Solid grey

REF.03512



Negro  
Black

REF.03492



Purpurina plata  
Silver glitter

REF.04084



Purpurina colores  
Glitter colours

REF.04086



**Tratamientos de uñas POLLIE**  
**POLLIE nail treatments**

12 ml

u.m.vta: 3  3

Top Coat "mate" secante  
 Matt top coat

REF.03913



Top Coat efecto "gel"  
 Gel effect Top Coat

REF.04261



Top coat. Brillo secante  
 Gloss coat . Nail drying

REF.03518



Base vitaminada  
 Vitamin-enriched base

REF.03514



Anti estrías  
 Nail anti stretch gloss

REF.03515



Endurecedor  
 Nail hardener

REF.03516



Quitacutícula gel  
 Cuticles gel remover

REF.03517



**Esmalte uñas flúor**  
**Neón nail polish**

u.m.vta: 3  3

12 ml

**NEW**

Azul  
 Blue

REF.07489



**NEW**

Rosa  
 Pink

REF.07490



**NEW**

Naranja  
 Orange

REF.07491



**NEW**

Amarillo  
 Yellow

REF.07492



### Carta colores esmalte POLLIE

#### POLLIE nail polish colours chart



u.m.vta: 1  150

Incluye 4 ruedas con los colores  
Includes 4 wheels with colours

**REF.06580**

### Spray secante de uñas

#### Drying nail spray

u.m.vta: 1  12 

200 ml

**REF.06693**

Acelera el secado del esmalte, realza su brillo y evita el deterioro del barniz. Vaporizar sobre las uñas recién pintadas, separando los dedos y a una distancia de unos 15 centímetros.

Accelerates the drying of the nail polish, enhances its shine and avoids the deterioration of the varnish. Spray on freshly painted nails, separating the fingers and at a distance of about 15 centimetres.

### Kit esmaltes "Back to basics"

#### "Back to basics" nail polishes kit

u.m.vta: 1  6

4 x12 ml

**REF.07154**

Ref. 1ud - 03423  
Ref. 1ud - 03501  
Ref. 1ud - 03502  
Ref. 1ud - 04477



### Kit esmaltes manicura francesa

#### French manicure nail polish kit

u.m.vta: 1  6

4 x12 ml

**REF.03863**

Ref. 1ud - 01200 lima  
Ref. 1ud - 00123 Baja pieles  
Ref. 1ud - 03514  
Ref. 1ud - 03495  
Ref. 1ud - 03507  
Ref. 1ud - 03528





### PASO A PASO ESMALTE P-LACK · STEP-BY-STEP P-LACK NAIL POLISH

1. Aplicar una fina capa de P-Lack base, sin tocar las cutículas ni el contorno de la uña. Sellar bien el borde de la uña con la misma base. Realizar esta operación en la primera mano y secar/polimerizar con una lámpara UV durante 120 segundos o con una lámpara LED 90 segundos. Repetir con la otra mano.
2. Posteriormente aplicar una fina capa de P-Lack colour, sin tocar las cutículas ni el contorno de la uña. Sellar bien el borde de la uña con el mismo color. Realizar esta operación en la primera mano y secar y polimerizar con una lámpara de UV durante 120 segundos o con una lámpara LED 90 segundos. Repetir esta misma operación con la otra mano.
3. Aplicar una segunda capa fina de P-Lack colour siguiendo las mismas indicaciones que en la primera capa. Muy importante sellar bien el borde de la uña.
4. Para una mayor duración con un acabado perfecto y brillante, aplicaremos una capa fina de P-Lack Gloss siguiendo las mismas indicaciones que en los casos anteriores.
5. Para finalizar: retirar los residuos pegajosos y desengasar las uñas humedeciendo una toallita de celulosa con el Nail Cleaner, limpiar uña a uña. Acabado final brillante y sin partes opacas.
6. Aplicar aceite en las cutículas y crema hidratante

1. Apply a thin layer of P-Lack base, without touching the cuticles or the contour of the nail. Seal the tip of the nail well with the same base. Do this on the first hand and dry / polymerize with a UV lamp for 120 seconds or with a LED lamp for 90 seconds. Repeat with the other hand.
2. Then apply a thin layer of P-Lack colour, without touching the cuticles or the contour of the nail. Seal the tip of the nail well with the same colour. Do this on the first hand and dry / polymerize with a UV lamp for 120 seconds or with a LED lamp for 90 seconds. Repeat this same operation with the other hand.
3. Apply a second thin layer of P-Lack colour following the same indications as in the first layer. Very important to seal the edge of the nail well.
4. For a longer duration with a perfect and shiny finish, we will apply a thin layer of P-Lack Gloss following the same indications as in the previous cases.
5. To finish: remove the sticky rests and degease the nails by moistening a cellulose wipe with the Nail Cleaner, cleaning nail to nail. Final finish bright and without opaque parts.
6. Apply cuticle oil and moisturizer

### Carta colores P-Lack P-Lack colours chart



u.m.vta: 1  100

REF.06558



**Esmaltes semipermanente P-LACK**  
**Semi-permanent nail polishes P-LACK**

9 g

u.m.vta: 1  6 



Dark Sky

REF.06247



Flames

REF.06246



Dark Rouge

REF.06245



Summer Fire

REF.06248



Violet Arrow

REF.06249



Pink Candy

REF.06250



Barbies dress

REF.06251



Pink Ribbon

REF.06253

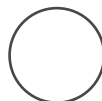

Pure White

REF.06254



Green Paradise

REF.06255



Clear Pink

REF.06256



Clear White

REF.06257



Chestnut

REF.06258





Baby Doll

REF.06262



**Esmaltes semipermanente P-LACK**  
**Semi-permanent nail polishes P-LACK**

9 g

u.m.vta: 1  6 



Top Coat

**REF.06260**



Top coat no wipe

**REF.07117**



Base

**REF.06261**



Black

**REF.06244**



Violet

**REF.06592**



Wine

**REF.06593**



French  
Pink

**REF.06594**



Red Ferrari

**REF.06595**



Glitter  
Top no wipe

**REF.07476**



Verde neón  
Neon green

**REF.06942**



Naranja neón  
Neon orange

**REF.06943**



Amarillo neón  
Neon yellow

**REF.06944**





Rose neón  
Neon pink

**REF.06945**



## Nail primer POLLÍÉ

### POLLÍÉ nail primer

u.m.vta: 1  6 

7 ml

REF.06673

Esmalte de uñas para asegurar la perfecta adherencia del gel y el acrílico. Contiene ácidos.

#### MODO DE USO:

- 1. Preparar las uñas
- 2. Aplicar una capa fina y dejar secar al aire
- 3. Aplicar el gel de construcción o acrílico y seguir con el proceso

#### Acid free

7 ml

REF.07116

*Nail polish to ensure perfect adhesion of gel and acrylic. It contains acid.*



#### DIRECTIONS:

- 1. Prepare the nails
- 2. Apply a thin layer and allow to air dry
- 3. Apply the construction gel or acrylic and continue with the process



## Nail prep P-LACK

### P-LACK nail prep

u.m.vta: 1  6 



15 ml

REF.07421



## Esmalte de uñas base/top

### Nail polish base/top coat

u.m.vta: 1  6 

9 g

REF.06674

Producto 2 en 1 transparente: base y top para el acrílico gel. Se aplica como base antes del acrílico gel y después como top para finalizar.

*Transparent 2 in 1 product: base and top coat for acrylic gel. It is applied as a base before the acrylic gel and then as a top coat to finish.*



## Acrylic gel

### Acrylic gel

u.m.vta: 1  12

60 g

REF.06597

Rosa transparente  
Transparent pink

60 g

REF.06598

Blanco  
White

60 g

REF.06599

Claro  
Clear

60 g

REF.06600

Camuflaje  
Camouflage

60 g

REF.06601

Rosa intenso  
Intense pink



Acrylic Gel es la combinación perfecta entre la técnica de acrílico y la de gel

MODOS DE USO:



- Lo mejor del acrílico: fuerza, duración y máxima dureza con esculpido más fino
- Lo mejor del gel: flexibilidad, sin olor, sin monómeros, limpio y fácil de rellenar. Disponible en 5 colores

Acrylic Gel is the perfect combination of acrylic and gel techniques

DIRECTIONS:

- The best of acrylic: strength, durability and maximum hardness with finer sculpture
- The best of the gel: flexible, odourless, monomer-free, clean and easy to refill. Available in 5 colours

**Nail prep P-LACK**  
**P-LACK nail prep**

u.m.vta: 1  16 

**REF.07422**

**Removedor esmalte P-LACK**  
**Remover soak off P-LACK**

**REF.06263**



- Acetona pura
- Perfume naranja
- Pure acetone
- Orange perfume

**Limpiador de uñas P-LACK**  
**Nail cleaner P-LACK**

**REF.06283**



**Quitaesmalte oleoso rosa**  
**Oily pink nail polish remover**

u.m.vta: 1  19 

150 ml

**REF.06608**

Quitaesmalte con acetona enriquecido con aceite de ricino. Elimina el esmalte de las uñas de forma suave dejándolas brillantes y perfumadas.

*Nail polish remover with acetone enriched with castor oil. Eliminates the nail polish gently leaving them bright and perfumed.*



**Quitaesmalte sin acetona**  
**Nail polish remover without acetone**

u.m.vta: 1  19

150 ml

**REF.07172**

Con aceite de ricino que hidrata las cutículas  
*With castor oil that hydrates the cuticles*

u.m.vta: 1  12 

1 L

**REF.06607**

- Con acetona
- With acetone



u.m.vta: 1  12

1 L



**REF.07173**

- Sin acetona,
- Acetone free





**Removedor esmalte P-LACK**  
**Remover soak off P-LACK**

u.m.vta: 1  19 

150 ml

REF.07109





u.m.vta: 1  12 

1 L

REF.07110



**Limpiador de uñas (limpiador/desengrasante)**  
**Nail cleaner (cleaner / degreaser)**

u.m.vta: 1  19 

150 ml

REF.07111



u.m.vta: 1  24 

400 ml

REF.07112

## Bote 10 remoja dedos individuales

### Bin 10 individual manicure bowls

u.m.vta: 1  12

REF.03879

- No usar con quitasmalte sin acetona
- Do not use with nail polish without acetone



## Láminas envoltentes para remover 100 uds

### Wrapped sheets to remove 100 units

u.m.vta: 1  107

100 u

REF.04824



Láminas de papel de aluminio con algodón incorporado para ser fácil y cómodo de aplicar con el remover o la acetona en la uña.

*Aluminum foil sheets with cotton incorporated to be easy and convenient to apply with the remover or acetone on the nail.*



## Crema de manos ultra hidratante nutritiva

### Ultra nourishing moisturizing hand cream

u.m.vta: 1  6 

Con dosificador  
With dispenser



500 ml

REF.07083

Una crema ultra-hidratante y nutritiva sin sensación grasa que envuelve las manos en un suave y poderoso velo reparador.

**El Aceite Rosa Mosqueta** resulta ser un poderosísimo regenerador para nuestra piel.

- Actúa de forma superficial como factor natural humectante, mejorando la hidratación
- Nutre y regenera
- Reduce la pérdida de agua en nuestra epidermis, ya que refuerza y multiplica la barrera de ceramides
- Corrige y previene los problemas cutáneos debidos al fotoenvejecimiento, a través de la autogeneración de melanina
- Revigora el fibroblasto, que es la célula dérmica productora del colágeno, ácido hialurónico, elastina y responsable de la firmeza y elasticidad de nuestra piel

u.m.vta: 1  17 

100 ml

REF.07082

*An ultra-moisturising, nourishing and non-greasy cream that envelops hands in a soft and powerful repairing veil.*

**Rose Hip Oil** is a powerful regenerator for our skin.

- It acts superficially as a natural moisturiser, improving hydration
- It nourishes and regenerates
- It reduces the loss of water in our epidermis since it reinforces and multiplies the ceramide barrier
- It corrects and prevents skin problems resulting from photo-ageing by fostering the self-generation of melanin
- It reinvigorates fibroblast, which is the dermal cell that produces collagen, hyaluronic acid, elastin and is responsible for the firmness and elasticity of our skin



**Pincel abanico con pelo sintético**  
**Fan brush synthetic hair**

u.m.vta: 1 12

REF.07097



REF.07098



- Grande
- Big

**Pinceles uñas acrílicas Kolinsky**  
**Kolinsky acrylic nail brushes**

u.m.vta: 1 12

- Pelo de marta

Considerado el mejor pelo para pinceles de uñas acrílicas por su resistencia y duración, por su gran elasticidad y máxima absorción del producto.

- Sable fur

Considered the best hair for acrylic nail brushes for its strength and durability, for its great elasticity and maximum absorption of the product.

Nº 2

REF.03659



Nº 4

REF.03660



Nº 6

REF.03661



Nº 8

REF.03662



Nº 10

REF.07648



Nº 12

REF.07649



NEW

NEW

**Pinceles uñas gel**  
**Gel nail brushes**

u.m.vta: 1 12

Nº 2

REF.03654



Nº 4

REF.03655



Nº 6

REF.03656



Nº 8

REF.03657



Nº 10

REF.03658



Nº 12

REF.07647



NEW

- Pelo de nylon
- Nylon hair

La uñas de gel, no se hacen con el pincel habitual de pelo Kolinsky que se utiliza para hacer uñas acrílicas. Recuerda, cuanto más grande sea el número de tu pincel, más grande será el grosor del mismo.

Si quieres esculpir uñas de gel, debes utilizar pinceles especiales que te faciliten la colocación del gel. Esto es, porque el gel es diferente al acrílico. Por esta razón, se emplean pinceles muy diferentes.

Actualmente los pinceles utilizados para aplicar gel son de nylon (sintéticos). PELO SINTÉTICO, VIOLA ALUMINIO, MANGO MADERA .

Gel nails are not made with the usual Kolinsky hair brush used to make acrylic nails. Remember, the bigger the number of your brush, the bigger the thickness of it.

If you want to sculpt nails in gel, you must use special brushes that facilitate the placement of the gel. This is because the gel is different from acrylic. For this reason, very different brushes are used.

Currently the brushes used to apply gel are nylon (synthetic). SYNTHETIC HAIR, ALUMINUM, WOOD HANDLE.

### Set 6 pinceles decoración uñas

### Set 6 nail brushes decoration

u.m.vta: 1  12



Pelo sintético  
Synthetic hair

REF.03653



### Pincel gel + empujador de cutículas

### Gel brush + cuticle pusher

u.m.vta: 1  12 



REF.06760



Nail art

### Pincel dotting para uñas

### Dotting nail brush

u.m.vta: 1  12 



REF.06761



Nail art

### Pincel gradient para uñas

### Gradient nail brush

u.m.vta: 1  12 

4 puntas de recambio  
4 replacement tips

REF.06762



Nail art

### Soporte negro de pinceles

### Black brushes holder

u.m.vta: 1  12 

REF.04822



### Set nail art

### Nail art set

u.m.vta: 1  42

REF.06759

- 15 pinceles para uñas
- 5 de doble punta de metal

- 15 nail brushes
- 5 double metal tip



### Manicuras originales Original manicures



Con los punzones podrás decorar las uñas y hacer infinidad de formas, líneas, puntos, flores, todos en diferentes colores. Los pinceles de punta fina te ayudarán a realizar esos pequeños detalles que harán de tus uñas una pequeña obra de arte.

*Our hallmarks will allow you to decorate nails and produce all kinds of shapes, lines, dots and flowers in different colours. Our fine-tip brushes will help you produce fine details to make your nails veritable little works of art.*

#### Set 5 punzones decoración uñas Pack 5 punches for nail decoration

u.m.vta: 1	12	
------------	----	--

REF.04093



#### Strass rhinestone nail art rueda Strass rhinestone nail art wheel

u.m.vta: 1	12	
------------	----	--

600 u

REF.06774



#### Fimo nail art flores y frutas rueda Fimo nail art flowers and fruits wheel



u.m.vta: 1	12	
------------	----	--

144 u

REF.04835



**Strass rhinestone colores nail art rueda**  
**Strass rhinestone colors nail art wheel**

u.m.vta: 1  12 

- Mini
- Mini

600 u

REF.07347



600 u

REF.07345



**Strass rhinestone plata nail art rueda**  
**Strass rhinestone silver nail art wheel**

144 u

REF.07346



**Donuts rhinestones nail art rueda**  
**Donuts rhinestones nail art wheel**

144 u

REF.07342



**Lentejuelas rhinestones nail art rueda**  
**Sequins rhinestones nail art wheel**

144 u

REF.07343



**Carroussel deko peace & love**  
**Peace & love carousel**



144 u

REF.07352





**Adhesivos 3D**  
**3D nail stickers**

u.m.vta: 1	 12	
------------	--	---

- Corazones blancos
- White hearts

**REF.04831**



- Mariposas blancas
- White butterfly

**REF.04832**



- Flores blancas
- White flower

**REF.04833**





- Flores de colores
- Coloured flower

**REF.04834**



**Lámina Nail art 1,5 m**  
**Nail art film 1,5 m**

u.m.vta: 1	 12	
------------	--	---



**REF.06770** Negra  
Black

**REF.06768** Dorada  
Golden

**REF.06769** Plateada  
Silver



**Cinta adhesiva para uñas 0,8 mm**  
**Sticky tape for nails 0.8 mm**

u.m.vta: 1  12 

**Negra**  
 Black

**REF.06773**

**Dorada**  
 Golden



**REF.06771**

**Plateada**  
 Silver

**REF.06772**



**Decoración para nail art**  
**Decoration for nail art**

u.m.vta: 1  12 

**Flores secaa. 12 colores**  
 Dried flowers. 12 colours

**REF.06763**



**Glitter surtido. 1 g x 12 colores**  
 Assortment of nail glitter. 1 g x 12 colours

**REF.06764**



**REF.06765**

- Polvos surtidos terciopelo
- 0,5 g x 12 colores
- Velvet dust
- 0.5 g x 12 colours

**REF.06766**



- Glitter escama sirena
- 1 g x 12 colores
- Mermaid scale glitter
- 1 g x 12 colours

**REF.06767**

- Pan de oro 12 colores
- Gold leaf
- 12 colours



**Decoración para nail art**  
**Decoration for nail art**

u.m.vta: 1  12 

**REF.07344**

- Bolas micro cristal caviar nail art 1,5g x 12
- *Micro crystal caviar nail art balls 1,5g x 12*



**REF.07348**

- Polvos glitter brillo nail art 1,5gx12 color
- *Glitter powder glitter nail art 1,5gx12 color*



**REF.07349**

- Polvos de arena nail art 1,5 g x 12 colores
- *Nail art sand powders 1.5g x 12 colours*



**REF.07350**

- Glitter surtido brillo nail art 1,5g x 12 colores
- *Assorted glitter nail art glitter 1.5g x 12 colors*



**REF.07351**



- Glitter flake rhombos 1,5 g x 12
- *Glitter flake rhombuses 1.5 g x 12*



**REF.07382**

- Paleta nacarada para nail art
- *Pearlescent nail art palette*



**Molde para uñas****Nail mold**u.m.vta: 1  32u.m.vta: 1  21

500 u

500 u

REF.04825

REF.04827

u.m.vta: 1  57

500 u



REF.04826





- Rectangular
- Rectangular

- Herradura medianos
- Medium-sized horseshoe

- Doble espesor
- Double thickness

**Dispensador transparente para moldes de uñas****Transparent dispenser for nail molds**u.m.vta: 1  4 

REF.04828

**Moldes para uñas reutilizables****Reusable nail molds**u.m.vta: 1  12 

5 u

REF.06750



**Guías para french manicure**  
**French manicure guides**

u.m.vta: 1  50

**REF.04829**

- Formas
- Forms



**REF.04830**



**Tips para uñas**  
**Nail tips**

u.m.vta: 1  46

100 u

**REF.06743**

- Naturales square
- Square natural



100 u

**REF.06744**

- Naturales curvados
- Curved natural



100 u

**REF.06745**

- Blancos square
- Square white

100 u

**REF.06746**

- Blancos curvados
- Curved white

100 u

**REF.06747**



- Transparentes square
- Transparent square

100 u

**REF.06748**

- Transparentes curvados
- Transparent curved

**Paleta de mezcla plástico para nail art**  
**Plastic mixing palette for nail art**



u.m.vta: 1  50 

REF.07477

**NEW**



**Paleta de mezcla metálica para nail art**  
**Metalic mixing palette for nail art**



u.m.vta: 1  50 

REF.07478

**NEW**



**Bolsa 10 paletas para demo**  
**Bag of 10 pallets for demo**



u.m.vta: 1  15 

Natural  
 Natural

REF.06751

06751



u.m.vta: 1  15 

Transparente  
 Transparent



REF.06752

06752







**Mano articulada para prácticas manicura**  
**Articulated hand for manicure practices**

u.m.vta: 1		10	
------------	---	----	---

**REF.07080**



**Recambio**  
**Spare part**

u.m.vta: 1		12	
------------	---	----	---

**REF.07081**

- Bolsa 100 uñas para mano articulada
- Bag of 100 spare nails

**Mano blanda prácticas manicura**  
**Soft hand manicure practices**

u.m.vta: 1		50
------------	---	----

**REF.04356**

- Apta para lámparas de secado
- Suitable for drying lamps





u.m.vta: 1		20
------------	---	----

**REF.04353**

- Apta para lámparas de secado
- Con soporte
- Suitable for drying lamps
- With support

## Celulosa precortada

### Cellulose strips

u.m.vta: 1	 12	
------------	--	---

REF. 03060



- Anónimo
- Anonymous

REF. 03060/00



Bolsa con 2 rollos de celulosa precortada a trozos de 4 x 5 cm. Cada rollo son 500 ud. de apósitos absorbentes. Ideal para retirar el esmalte de uñas sin dejar rastro de pelusas. Ø 15 · Peso: 155 g. Tolerancia 15 g.

Bag with 2 cellulose rolls pre-cut in 4 x 5 cm pieces. Each roll has 500 units of absorbent dressings. Ideal to remove nail polish without leaving any fuzz behind. Ø 15 · Weight: 155 g. Tolerance 15 g.

## Dispensador + 1000 pad nail

### Dispenser + 1000 pad nail

u.m.vta: 1	 12
------------	--

REF.06471



Cuadraditos precortados cómodos de usar y que no dejan pelusas. Ideal para retirar el esmalte con acetona o la capa pegajosa del semipermanente.

Pre-cut squares comfortable to use and that do not leave lint. Ideal to remove the nail polish with acetone, or the sticky layer of the semi-permanent.



## Cinta protectora

### Protective tape

u.m.vta: 1	 12	
------------	--	---



- Rosa
- Pink

REF.06757



## Godet tubo 5 uds

### Tube shaped dappen dish 5 pcs



u.m.vta: 1	 12	
------------	--	---

- Plástico
- Plastic

REF.06758



### Vasito para manicura Manicure glass

u.m.vta: 1  160 

- Cristal
- Glass

REF.06756



### Recipiente cerámico tapón corcho Ceramic bowl with cork stopper

u.m.vta: 1  48

- Blanco
- White

REF.06775



### Clips soak off remover 10 uds Soak off remover clips 10 pcs

u.m.vta: 1  106

- Blancos
- White

REF.06777





- Rosa
- Pink

REF.06778



### Lámpara de uñas UV-led 65W modelo: Silver LIGHT Uv-led 65W nail lamp model: Silver LIGHT

u.m.vta: 1  12 

REF. 07186



SCAN  
ME!

- Potencia: 65 W
- Peso: 450 g
- Led UV: 33 unidades
- Longitud de onda Leds: 395-405nm
- Voltaje: 100 – 240V
- Frecuencia 50/60 Hz
- Temporizador: 10", 30", 60", y 99"segundos
- Salida adaptador: DC 24V= 2A
- Temperatura de trabajo: -10°C – 35°C
- Base metálica extraíble imantada

- Power: 65 W
- Weight: 450 g
- LED/UV:33 units
- LED wavelength: 395 - 405 nm
- Voltage: 100 – 240 V~
- Frequency 50/60 Hz
- Timer: 10", 30", 60" and 99" seconds
- Output: DC 24V = 2A
- Working temperature: -10°C – 35°C
- Removable magnetic metal base.





Les presentamos nuestras lámparas LED UV de 48W (Ref.06638 modelo MOON LIGHT y 06639 modelo SUN LIGHT), son el complemento ideal para el secado rápido y seguro de los esmaltes de uñas semipermanentes y geles de reconstrucción en manicura/pedicura, así como los formulados especialmente para secado LED.

*These are our LED lamps. They come in 48 Watt (Ref. 06638 MOON LIGHT and Ref. 06639 ENERGY LIGHT). The ideal complement for drying semi-permanent nail polishes and UV gels in manicures and pedicures, as well as those specially formulated for LED drying quickly and safely.*

### Lámpara de uñas UV-led 48W modelo: MOON LIGHT

#### Uv-led 48W nail lamp model: MOON LIGHT

u.m.vta: 1  12 

REF. 06638





SCAN ME!

- Potencia: 48 W
- Peso: 450 g
- Led UV: 21 unidades
- Longitud de onda Leds: 395-405nm
- Voltaje: 100 – 240V
- Frecuencia 50/60 Hz
- Temporizador: 30", 60" y 99" segundos
- Salida adaptador: DC 24V 1,5A
- Temperatura de trabajo: -10°C – 35°C

- Power: 48 W
- Weight: 450 g
- LED/UV: 21 units
- LED wavelength: 395 - 405 nm
- Voltage: 100 – 240 V-
- Frequency 50/60 Hz
- Timer: 30", 60" and 99" seconds
- Output: DC 24V 1.5A.
- Working temperature: -10°C – 35°C

### Lámpara de uñas UV-led 48W modelo: SUN LIGHT

#### Uv-led 48W nail lamp model: SUN LIGHT

u.m.vta: 1  8 

REF. 06639



SCAN ME!



- Potencia: 48 W
- Peso: 560g
- Led/UV: 24 unidades
- Longitud de onda Leds: 395-405 nm
- Voltaje: 100 – 240V~
- Frecuencia 50/60 Hz
- Temporizador: 10", 30", 60" y 99" segundos
- Salida Adaptador: DC 24V 1.5A
- Temperatura de trabajo: -10°C – 35°C
- Base desmontable

- Power: 48W
- Weight: 560 g
- LED/UV: 24 units
- LED wavelength: 395 - 405 nm
- Voltage: 100 – 240 V-
- Frequency 50/60 Hz
- Timer: 10", 30", 60" and 99" seconds
- Output: DC 24V 1.5A.
- Working temperature: -10°C – 35°C
- Detachable base

Les presentamos nuestras lámparas LED UV de 48W (Ref.06640 modelo POWER LIGHT y 06641 modelo FAST LIGHT), son el complemento ideal para el secado rápido y seguro de los esmaltes de uñas semipermanentes y geles de reconstrucción en manicura/pedicura, así como los formulados especialmente para secado LED.

*These are our LED lamps. They come in 48 Watt (Ref. 06640 POWER LIGHT and Ref. 06641 FAST LIGHT). The ideal complement for drying semi-permanent nail polishes and UV gels in manicures and pedicures, as well as those specially formulated for LED drying quickly and safely.*

### Lámpara de uñas UV-led 48W modelo: POWER LIGHT UV-led 48W nail lamp model: POWER LIGHT

u.m.vta: 1  8 

REF. 06640

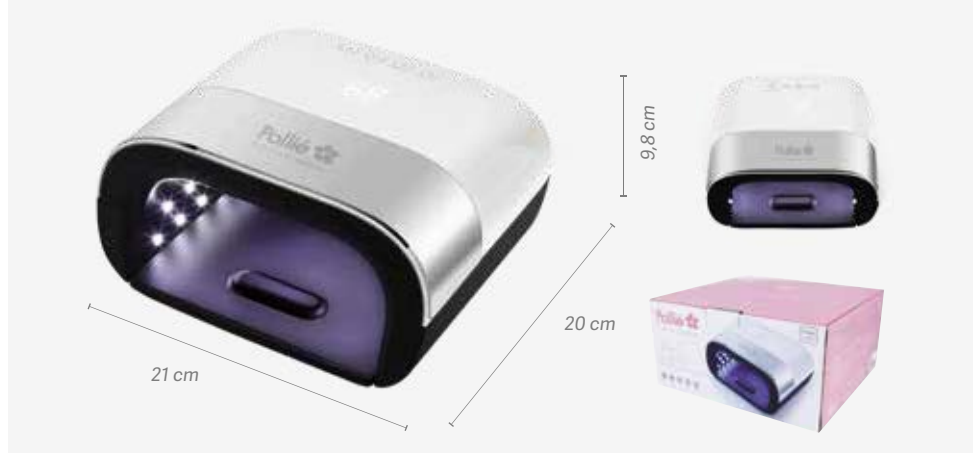



SCAN  
ME!

- Potencia: 48 W
- Peso: 880 g
- Led UV: 36 unidades
- Longitud de onda Leds: 395-405 nm
- Voltaje: 100 – 240V~
- Frecuencia 50/60 Hz
- Temporizador: 30", 60" y 99"segundos
- Salida adaptador: DC 24V 1,5A
- Temperatura de trabajo: -10°C – 35°C
- Base desmontable
- Para manicura y pedicura

- Power: 48W
- Weight: 880 g
- LED/UV: 36 units
- LED wavelength: 395 - 405 nm
- Voltage: 100 – 240 V~
- Frequency 50/60 Hz
- Timer: 30", 60" and 99" seconds
- Output: DC 24V 1.5A.
- Working temperature: -10°C – 35°C
- Detachable base
- For manicure and pedicure

### Lámpara de uñas UV-led 48W modelo: FAST LIGHT UV-led 48W nail lamp model: FAST LIGHT

u.m.vta: 1  8 

REF. 06641

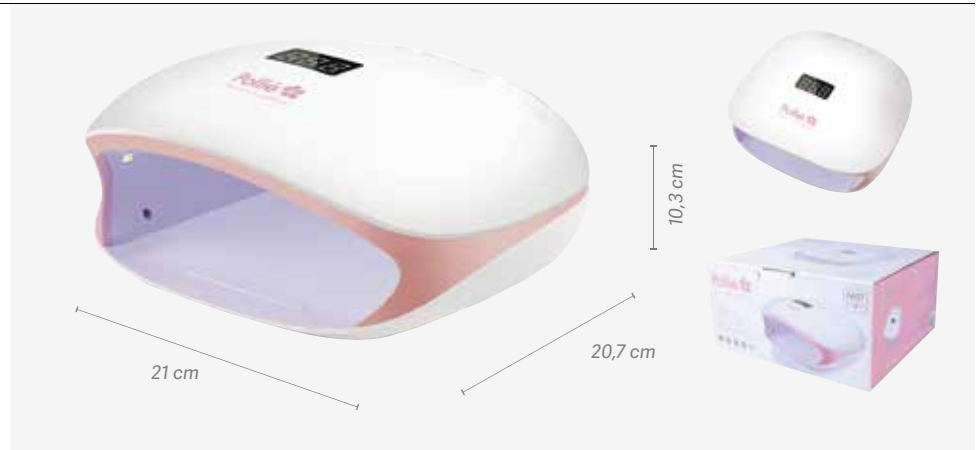

SCAN  
ME!

- Potencia: 48 W
- Peso: 740 g
- Led/UV: 36 unidades
- Longitud de onda Leds: 395-405 nm
- Voltaje: 100 – 240V~
- Frecuencia 50/60 Hz
- Temporizador: 10", 30", 60" y 99"segundos
- Salida adaptador: DC 24V 1.5A
- Temperatura de trabajo: -10°C – 35°C
- Base desmontable

- Power: 48W
- Weight: 740 g
- LED/UV: 36 units
- LED wavelength: 395 - 405 nm
- Voltage: 100 – 240 V~
- Frequency 50/60 Hz
- Timer: 10", 30", 60" and 99" seconds
- Output: DC 24V 1.5A
- Working temperature: -10°C – 35°C
- Detachable base



Les presentamos nuestras lámparas led de 24W (ref.04919 modelo STAR LIGHT) y de 48W (ref. 04920 modelo ENERGY LIGHT). Son el complemento ideal para el secado de los esmaltes de uñas semipermanentes y geles de reconstrucción en manicura y pedicura, así como los formulados especialmente para secado led.

*We present our 24W led lamps (ref.04919 STAR LIGHT model) and 48W (ref 04920 ENERGY LIGHT model). They are the ideal complement for the drying of semi-permanent nail polishes and manicure and pedicure reconstruction gels, as well as those formulated especially for LED drying.*

### Lámpara led UV 24W STAR LIGHT

UV-led model: 24W STAR LIGHT

STAR  
Light

u.m.vta: 1  12 

REF. 04919



SCAN  
ME!





- Potencia: 24W
- Leds/UV: 15 unidades
- Longitud de onda Leds: 395-405 nm
- Voltaje: 100-240V~
- Frecuencia 50/60 Hz
- Temporizador: 10", 30", 60" y 99" segundos
- Base desmontable para manicura y pedicura

- Power: 24W
- Led / UV bulbs: 15 units
- Wavelength Leds: 395-405 nm
- Voltage: 100-240V ~
- Frequency 50/60 Hz
- Timer: 10 ", 30 ", 60 " and 99" seconds
- Removable base for manicure and pedicure

### Lámpara led UV 48W ENERGY LIGHT

UV-led model: 48W ENERGY LIGHT

ENERGY  
Light

u.m.vta: 1  12 



REF. 04920



- Potencia: 48 W
- Leds/UV: 24 unidades
- Longitud de onda Leds: 395-405 nm
- Voltaje: 100-240V~
- Frecuencia 50/60 Hz
- Temporizador: 10", 30", 60" y 90"segundos
- Base desmontable para manicura y pedicura

- Power: 48 W
- Led / UV bulbs: 24 units
- Wavelength Leds: 395-405 nm
- Voltage: 100-240V ~
- Frequency 50/60 Hz
- Timer: 10 ", 30 ", 60 " and 90" seconds
- Removable base for manicure and pedicure



**Recambios bombillas · Bulb replacement**9W UV  
9W UV**REF. RE03150/01**9W UV led  
9W UV led**REF. RE04354/02****Mini lámpara led 2W portátil USB**  
**Led mini lamp 2W USB**u.m.vta: 1  72 **REF. 04355**

- Potencia: 2W
- Especial para uñas de gel, esmalte semi-permanente
- Luz UV 365 nm
- Temporizador 10"
- CABLE USB INCLUIDO
- Ideal para llevar de viaje y transportar por su pequeño tamaño de bolsillo

- Power: 2W
- Especially intended for gel nails, semi-permanent nail polish
- 365 nm UV light
- 10" timer
- USB CABLE INCLUDED
- Ideal to travel with or carry around owing to its small, pocket-sized design



## Spa manicura Manicure spa

u.m.vta: 1  24



REF. 04265

- Potencia: 2W
- Batería no incluida
- Masaje estimulante de burbujas pre-manicura que suaviza las cutículas
- Voltaje: 100-240V~
- Frecuencia 50/60 Hz

- Power: 2W
- Battery not included
- Stimulating pre-manicure bubble massage that softens the cuticles
- Voltage: 100-240V ~
- Frequency 50/60 Hz



## Aspirador manicura Manicure vacuum

u.m.vta: 1  8 

REF. 04205

Aspirador de sobremesa para el polvo de la manicura, elegante y muy funcional, diseño actual y novedoso. Recoge perfectamente el polvo que se hace al afilar las uñas. Mediante el torno, el polvo va a parar debajo del aspirador, en una bolsa adecuada, evitando así respirar restos de polvo.

- Potencia: 23W
- Batería no incluida
- Con 3 bolsas de recambio



*Tabletop vacuum cleaner for manicure dust. It is both elegant and functional, with a modern and innovative design. This vacuum cleaner easily cleans up the dust produced when sharpening nails or when using a lathe; the dust is collected below the vacuum cleaner, in a suitable bag, thus helping avoid that any of the dust is inhaled.*

- Power: 23W
- Battery not included
- With 3 spare bags



## Parafina: hidrata y nutre tus manos y pies

### Paraffin: moisturize and nourish your hands and feet

u.m.vta: 1  24 

- Hidrata en profundidad
- Mejora notablemente el aspecto de la piel
- Elastiza la piel
- Mejora la microcirculación sanguínea
- Favorece la absorción de activos
- Ayuda a eliminar líquidos y toxinas
- Mejora las contracturas y facilita el masaje
- Calma el dolor y la inflamación

- Hydrates in depth
- Noticeably improves the appearance of the skin
- Elasticizes the skin
- Improves blood microcirculation
- It favors the absorption of assets
- Helps to eliminate liquids and toxins
- Improves contractures and facilitates massage
- Calms pain and inflammation

REF. 04671

#### Parafina monoï de Tahití y menta

Tratamiento restaurador-tonificador de la piel de manos y pies. El Monoï de Tahití equilibra el manto hidrolipídico natural de la piel. La vuelve más elástica y proporciona una gran capacidad para retener la humedad. Gracias al aceite de menta tonifica y refresca la piel.

*Paraffin monoï Tahiti and mint*  
Restorative-tonifying treatment of hands and feet skin. Monoï de Tahiti balances the natural hydrolipidic of the skin. It makes it more elastic and provides a great capacity to retain moisture. Thanks to the mint oil, it tones and refreshes the skin.

REF. 04672

#### Parafina naranja y melocotón

Tratamiento nutritivo-protector de la piel de manos y pies. Rica en carotenos, tiene importantes propiedades antioxidantes. Es un tratamiento ideal para pieles maduras y deshidratadas.

*Paraffin orange and peach*  
Nourishing-protective treatment of hands and feet skin. Rich in carotenes, it has important antioxidant properties. It is an ideal treatment for mature and dehydrated skin.

REF. 04673

#### Parafina manteca de karité



Tratamiento antioxidante. La Manteca de Karité es uno de los mejores hidratantes y emolientes por excelencia. Proporciona bienestar y protección a la piel.

*Paraffin karité butter*  
Antioxidant treatment Shea butter is one of the best moisturizers and emollients par excellence. Provides wellness and protection to the skin.



## Calentador de parafina digital y con memoria de temperatura

### Paraffin heater digital and with temperature memory

u.m.vta: 1  6 

REF. 06335

- Potencia: 200 W
- Capacidad: 2 Kg
- Voltage: 220-240V~
- Frecuencia: 50 Hz
- Temperatura: 40°C hasta 70°C
- Apto para pies y manos

- Power: 200W
- Capacity: 2Kg.
- Voltage: 220-240 V~
- Frequency: 50Hz
- Temperature: 40°C up to 70°C
- Suitable for feet and hands



**Bolsa 2 guantes protector piel anti UV, antimanchas**  
**Bag of 2 skin protecting anti-UV gloves, anti-stain**

u.m.vta: 2  200

**REF. 04686**



**Bolsa 2 manoplas rizo parafina**  
**Bag 2 cotton gloves for paraffin**

u.m.vta: 1  200

**REF. 06615**



**Bolsa 2 peucos rizo parafina**  
**Bag 2 cotton feet gloves for paraffin**

u.m.vta: 1  200

**REF. 06616**



Manoplas de rizo para el tratamiento de parafina. Su forro interior permite mantener la temperatura para un óptimo resultado del tratamiento.

*Bag 2 cotton gloves for paraffin use. Their inner lining keep the temperature for an optimal result of the treatment.*

Peucos de rizo para el tratamiento de parafina. Su forro interior permite mantener la temperatura para un óptimo resultado del tratamiento.

*Bag 2 cotton feet gloves for paraffin use. Their inner lining keep the temperature for an optimal result of the treatment.*

**Pack 50 bolsas plástico parafina**  
**Pack 50 paraffin plastic bags**

u.m.vta: 1  300

**REF. 06617**

Bolsas de plástico para el tratamiento de la parafina tanto de manos como de pies. Intensifican el calor e impiden que se evapore rápidamente.

*Pack 50 plastic bags for paraffin treatments in hands and feet. They intensify heat and prevent it from evaporating too quickly*



### Torno profesional 30.000 rpm Professional drill 30,000 rpm

u.m.vta: 1	 8
------------	---

REF. 06624



Torno de excelentes prestaciones para un trabajo profesional. Motor silencioso y manípulo ligero que permite trabajar cómodamente.



- Potencia: 45 W
- Voltaje: 220 V
- Peso manípulo: 146 g
- Peso base motor: 1250 g

*Excellent performance drill for professional results. Silent motor and lightweight handle for comfortable working.*

- Power: 45W
- Voltage: 220 V
- Handle weight: 146 g
- Engine base weight: 1250 g



### Torno profesional 30.000 rpm Professional drill 30,000 rpm

u.m.vta: 1	 12	
------------	--	---

REF. 06625

Torno con una fabulosa relación calidad/precio sensacional. Silencioso y duradero pensado para la profesional y la aprendiz.

- Potencia: 30 W
- Voltaje: 110 - 220 V
- Peso manípulo: 130 g
- Peso base motor: 730 g

*Drill with a fabulous quality price ratio sensational. Silent and durable designed for the professional and the apprentice*

- Power: 30 W
- Voltage: 110 - 220 V
- Handle weight: 130 g
- Engine base weight: 730 g



Incluye: 6 accesorios (fresas) + 6 esmeriles  
Includes: 6 accessories + 6 emery cones

### Torno manicura **POCKET** **POCKET manicure drill**

Incluye: 6 accesorios (fresas) + 6 esmeriles  
Includes: 6 accessories + 6 emery cones

u.m.vta: 1  12

**REF. 06695**



- Potente, silencioso y portátil
- Diseño compacto perfecto para viajar
- Muy ligero
- 10 horas de autonomía
- Velocidad: 30.000 RPM
- Potencia: 24 W
- Capacidad de la batería: 2.000 mA (11.1V)
- Tiempo de carga de batería: 2 horas
- Duración de la batería a máxima velocidad: 10 horas
- Muy silencioso, no se calienta ni vibra
- Peso petaca: 283 g
- Peso manípulo: 157 g
- Voltaje: 110 – 220 V
- Class II 50/60 Hz

- *Powerful, quiet and portable*
- *Compact design perfect for travel*
- *Very lightweight*
- *10 hours of autonomy*
- *Speed: 30.000 CPM*
- *Power: 24W*
- *Battery capacity: 2000 mA (11.1V)*
- *Battery charging time: 2 hours*
- *Battery life at maximum speed: 10 hours*
- *Very quiet, does not heat or vibrate*
- *Battery weight: 283 g*
- *Handle weight: 157 g*
- *Voltage: 110 – 220 V*
- *Class II 50/60 Hz*
- *Classe II 50/60 Hz*



### Torno manicura **QUICK** **QUICK manicure drill**

Incluye: 6 accesorios (fresas) + 6 esmeriles  
Includes: 6 accessories + 6 emery cones

u.m.vta: 1  8 

**REF. 06696**



- Potente y silencioso
- Diseño compacto perfecto para viajar
- Muy ligero
- Velocidad: 30.000 RPM
- Potencia: 24 W
- Muy silencioso, no se calienta ni vibra
- Peso torno: 341 g
- Peso manípulo: 155 g
- Voltaje: 110 – 220 V
- Class II 50/60 Hz.

- *Powerful and quiet*
- *Compact design perfect for travel*
- *Very lightweight*
- *Speed: 30.000 CPM*
- *Power: 24W*
- *Very quiet, does not heat or vibrate*
- *Drill weight: 341 g*
- *Handle weight: 155 g*
- *Voltage: 110 – 220 V*
- *Class II 50/60 Hz*





**Recambios para tornos**  
**Spare parts for drills**

u.m.vta: 1  12 

- REF. 06779**
- Mandril adaptador para cilindros esmeriles
  - Adapter mandrel for grinding cylinders

- REF. 06780**
- Escobilla pulidora
  - Ø 0,65
  - Polishing brush diameter
  - Ø 0,65

- REF. 06781**
- Cono de piedra fieltro
  - Ø 0,6
  - Stone felt cone diameter
  - Ø 0,6



- REF. 06782**
- Fresa piedra forma de barril
  - Ø 0,6
  - Barrel drill
  - Ø 0,6

- REF. 06783**
- Fresa piedra cónica
  - Ø 0,4
  - Conical stone drill
  - Ø 0,4

- REF. 06784**
- Fresa diamante con punta redonda
  - Diamond drill with round tip



- REF. 06785**
- Fresa diamante cilíndrica forma pera
  - Cylindrical diamond drill



- REF. 06786**
- Fresa diamante cilíndrica barril grande
  - Cylindrical barrel diamond drill

- REF. 06787**
- Fresa diamante cilíndrica barril mediana
  - Cylindrical barrel diamond drill



## Recambios para tornos

### Spare parts for drills

u.m.vta: 1  12 

#### REF. 06788

- Fresa diamante cilíndrica barril
- Cylindrical barrel diamond drill

#### REF. 06789

- Fresa diamante aguja
- Diamond needle drill

#### REF. 06790

- Fresa de silicona pulidora grano
- Grain polishing silicone drill



#### REF. 06791

- Fresa de cerámica barril diámetro
- Ø 0,66
- Ceramic barrel drill diameter
- Ø 0,66

#### REF. 06792

- Fresa cerámica barril con punta redonda
- Ø 0,66
- Ceramic barrel drill with a round tip
- Ø 0,66

#### REF. 06793

- Fresa cerámica aguja diámetro
- Ø 0,23
- Ceramic needle drill diameter
- Ø 0,23



#### REF. 06794

- Fresa cerámica cónica diámetro
- Ø 0,6
- Ceramic conical drill diameter
- Ø 0,6

#### REF. 06795

- Fresa tungsteno azul cónica
- Ø 0,6
- Conical blue tungsten drill
- Ø 0,6



**Kit accesorios**  
**Accessories kit**

6 accesorios + 6 esmeriles  
6 accessories + 6 emery cones

u.m.vta: 1  500

**REF. 06626**



**Dispensador 100 cilindros esmeriladores**  
**Dispenser 100 fine grinding cylinders**

u.m.vta: 1  30

**REF. 06627**

- Finos
- Dureza: 180
- Thin
- Toughness: 180

**REF. 06628**

- Medio
- Dureza: 120
- Medium
- Toughness: 120

**REF. 06629**

- Grueso
- Dureza: 80
- Thick
- Toughness: 80



## Torno PROMED 620

### PROMED 620 drill

u.m.vta: 1  6

REF. 04103



- Potencia: 21W
- Torno doble sentido con 10 accesorios y 30 esmeriles
- El torno profesional de mesa más pequeño del mercado
- Adecuado para el tratamiento de uñas de manos y pies, como para el de uñas postizas, de gel o acrílicas
- Elimina fácilmente callos y durezas
- Tamaño reducido: 11 x 9 x 8 cm
- Resistente a la acetona con motor refrigerado (75g)
- Soporte de apoyo torno integrado en la base
- Incluye diferentes fresas y conteras (10 accesorios + 30 esmeriles)
- Cierre rápido automático para fresas o conteras estándar de 2,25mm
- Interruptor con protector contra el polvo
- Revoluciones regulables sin escalonamientos hasta 20,000 rpm
- Voltaje: 115-230V~
- Frecuencia: 50/60 Hz

- Power: 21W
- Double direction drill with 10 accessories + 30 grinding stones
- The smallest professional tabletop drill on the market
- Suitable for treating fingernails and toenails as well as artificial, gel or acrylic nails
- Easily removes calluses and corns
- Small size: 11 x 9 x 8 cm
- Acetone-resistant, with a refrigerated motor (75g)
- Drill support bearing integrated into the base
- Includes different lathes and ferrules (10 accessories + 30 grinding stones)
- Quick, automatic closure for standard 2,25mm lathes or ferrules
- Switch with a dust protection cap
- Continuous adjustable rounds per minute up to 20,000 rpm
- Voltage: 115-230V ~
- Frequency: 50/60 Hz

## Torno PROMED PERFECT

### PROMED PERFECT drill

u.m.vta: 1  12

REF. 03222

- Potencia: 13 W
- 12,000 RPM
- Doble sentido
- 10 accesorios + 30 esmeriles + 1 cepillo
- Luz fría incorporada para iluminar la zona a trabajar
- Voltaje: 220-230V~
- Frecuencia: 50 Hz

- Power: 13 W
- 12,000 RPM
- Two-way power
- 10 accessories + 30 grinding stones + 1 brush
- Integrated cold light to illuminate the working area
- Voltage: 220-230V ~
- Frequency: 50 Hz



### Torno MP840 manicura/pedicura MP840 drill manicure/pedicure

u.m.vta: 1		4
------------	---	---

REF. 06443

#### Cuidado y tratamiento de uñas, cutículas y callosidades. Con luz led para una aplicación más precisa y apto para diabéticos.

- Accesorios para el pulido de las uñas incluidos: 2 rodillos de pulido y 2 de abrillantado
- Con 7 accesorios de alta calidad para diferentes aplicaciones
- Rotación a la derecha y a la izquierda, diseño ergonómico
- Se detiene automáticamente cuando la presión es demasiado alta
- Tamaño: 15 x 3,8 x 3,7 cm
- Peso: 101 g
- Tensión: 230V, 50 hz
- Velocidad de rotación: 3 niveles de 3.500 / 5.000 / 8.000 rpm
- Longitud del cable: 1,5 m
- Con bolsa de almacenamiento

#### Care and treatment of nails, cuticles and calluses. With an LED light for a more precise application and suitable for people with diabetes.

- Nail polishing accessories included: 2 polishing rollers and 2 buffing rollers
- With 7 high-quality accessories for different uses
- Right and left-hand rotation, ergonomic design
- It stops automatically when the pressure is too high
- Size: 15 x 3.8 x 3.7 cm
- Weight: 101 g
- Voltage: 230V, 50 Hz
- Rotational speed: 3 levels of 3,500 / 5,000 / 8,000 rpm
- Cable length: 1,5 m
- With a travel bag



### Torno MP815 manicura/pedicura MP815 manicure/pedicure screw

u.m.vta: 1		4
------------	---	---

REF. 06444

#### Cuidado y tratamiento de uñas, cutículas y callosidades. Torno con 7 accesorios de alta calidad para diferentes aplicaciones. Apto para diabéticos.

- Rotación a la derecha y a la izquierda, diseño ergonómico
- Se detiene automáticamente cuando la presión es demasiado alta
- Tamaño: 15 x 3,8 x 3,7 cm
- Peso: 101 g
- Tensión: 230V, 50 HZ
- Velocidad de rotación: 2 niveles de 3.500 / 4.600 rpm
- Longitud del cable: 1,5 m
- Con bolsa de almacenamiento

#### Care and treatment of nails, cuticles and calluses. A nail drill with 7 high-quality accessories for different uses Suitable for people with diabetes.

- Right and left-hand rotation, ergonomic design
- It stops automatically when the pressure is too high
- Size: 15 x 3.8 x 3.7 cm
- Weight: 101 g
- Tension: 230V, 50 HZ
- Rotational speed: 2 levels of 3,500 / 4,600 rpm
- Cable length: 1,5 m
- With a travel bag



**Recambios para tornos**  
**Spare parts for drills**

u.m.vta: 1  10



**REF. 06443**



**REF. 06444**

**REF. 02149**



- Cono fieltro
- Felt cone

**REF. 02150**



- Cono zafiro grano fino
- Sapphire cone thin bean

**REF. 02151**



- Cono zafiro grano grueso
- Sapphire cone thick bean

**REF. 02152**



- Disco zafiro grano fino
- Sapphire disc thin bean

**REF. 02153**



- Fresa zafiro
- Sapphire drill

**REF. 02154**



- Cortador de aguja
- Needle cutter

**REF. 02155**



- Cono zafiro grande
- Sapphire cone large

**REF. 02156**



- Empuja pieles
- Pull out cuticle

**REF. 02157**



- Cortador cilíndrico
- Cylindric cutter

**REF. 02158**



- Disco zafiro grano grueso
- Shapphire disc thick bean

**REF. 02159**



- Cortador zafiro ovalado
- Sapphire cutter oval

**REF. 02164**



- Escoba
- Broom to polish

**REF. 02165**



- Adaptador de fresas
- Drill adapter

**REF. 02160**



- Adaptador con 30 tubos esmeriles
- 30 emery tube with 1 adapter



**Recambios para tornos**  
**Spare parts for drills**

u.m.vta: 1  10



REF. 04103



REF. 03222

REF. 02958



★

- Esmerilador cónico zafiro
- Abrasive cone, sapphire rough

REF. 02959



★

- Fresa puntiaguda zafiro
- Sapphire milling cutter, pointed

REF. 02960



★

- Fresa redonda zafiro
- Sapphire milling cutter, round

REF. 02961



★

- Disco limador zafiro, grano fino
- Abrasive disc, sapphire, fine-grained

REF. 02962



★

- Cono pulidor/filtro
- Felt cone buffer

REF. 02976



★

- Adaptador cilindro esmeril
- Abrasive mandrel, plastics

REF. 02980



★

- Pulidor silicona medio
- Silicone polisher medium

REF. 02981



★

- Pulidor silicona grueso
- Silicone polisher thick

REF. 02982



★

- Fresa larga
- Milling cutter long

REF. 02983



★

- Esmerilador pedicura callosidades
- Hard skin abrader sapphire rough

\*No esterilizable con presión ni con temperatura (autolavable, esterilizador cuarzo)  
Solamente desinfectable con desinfectante o alcohol

\*Not sterilizable with pressure or temperature (self-wash, quartz sterilizer)  
Only disinfected with disinfectant or alcohol

**Disco zafiro grano medio**  
**Medium grain sapphire disc**

u.m.vta: 1  12 

REF. 07237

- Para torno de manicura-pedicura
- For manicure-pedicure lathe



### Lupa con luz LED Magnifying glass with light LED

u.m.vta: 1  4

REF. 03821



- Potencia: 5W
- Lente 5 dioptrías
- Diámetro lente: 10,16 cm
- Iluminación: 48 leds
- Tapa protectora para lente, base de lupa con peso para sobremesa
- Voltaje: 220-240V~
- Frecuencia: 5 Hz

- Power: 5W
- Lens 5 diopters 10.16 cm
- Lighting: 48 leds
- Protective lid for the lens, the base of the lens has a weight for tabletop use
- Voltage: 220-240V ~
- Frequency: 5 Hz

### Lupa con luz led Magnifying glass with led light

u.m.vta: 1  4

REF. 04948



- Potencia: 5W
- Lente 5 dioptrías
- 60 Smd leds tiene 6 niveles de graduación modo frío y cálido
- 800 lumen
- Máxima luz, con reproducción muy real de los colores, larga duración y muy bajo consumo
- Índice de reproducción cromática, es de un 80% reproduciendo los colores fielmente
- No genera calor
- Diámetro cristal lupa 12.7 cm
- Grosor cristal de 0,5 a 2,1 cm
- 100-240V AC 50-60hz

- Power: 5W
- Lens 5 diopters
- 60 Smd leds has 6 graduation levels hot and cold mode
- 800 lumen
- Maximum light, with very real reproduction of the colors, long lasting and very low consumption
- The index of chromatic reproduction cri is 80% reproducing the colors faithfully
- Not generate heat
- Lamp crystal diameter 12.7 cm
- Thickness crystal 0.5 to 2.1 cm
- 100-240V AC 50-60hz

### Lupa con luz Magnifying glass with light

u.m.vta: 1  10 

REF. 04624

- Lámpara mesa manicura con pie y pinza
- Lente 5 dioptrías
- Tamaño lente: 100 mm
- Iluminación: 30 led smd
- Voltaje: 100-240V
- Frecuencia: 50/60 Hz
- Potencia máxima: 6W
- Brazo tipo cisne para soporte lupa
- Clip antideslizante incluido para mesa
- Uso en interiores
- 560 lumen para uso profesional

REF. 04947

- Manicure table lamp with base and clamp
- Lens 5 diopters
- Lens size: 100 mm
- Illumination: 30 led smd
- Voltage: 100-240V
- Frequency: 50/60 Hz
- Maximum power: 6W
- Swivel arm for magnifying glass
- Anti-slip clip included for table
- Use indoors
- 560 lumen for professional use



Con accesorio extra para enganche mesa  
With extra handle to hold table

## Lupa con luz led Magnifying glass with led light

u.m.vta: 1  4

3 dioptrías  
3 dioptres  
**REF. 03815**

5 dioptrías  
5 dioptres  
**REF. 03816**

8 dioptrías  
8 dioptres  
**REF. 03817**

- Potencia: 22W
  - Tamaño de la lente: 12,7 cm
  - Tapa protectora para lente
  - Brazo articulado para soporte lupa
  - Mordaza incluida para mesa
- Power: 22W
  - Lens size: 12,7 cm
  - Protective lid for lens
  - Articulated arm to hold the lens
  - Table clamp included



## Lupa led SMD Led magnifying glass SMD

u.m.vta: 1  1

3 dioptrías  
3 diopters  
**REF. 04107**

5 dioptrías  
5 diopters  
**REF. 04108**

8 dioptrías  
8 diopters  
**REF. 04109**

- Potencia: 22W
- Tamaño de la lente: 12,7 cm
- 60 LEDS SMD Y 570 LUMENS
- Máxima luz, con reproducción muy real de los colores, larga duración y muy bajo consumo 6W
- No generan calor

- Power: 22W
- Lens size: 12,7 cm
- 60 SMD leds AND 570 LUMENS
- Maximum light with faithful colour reproduction, long service life and low energy consumption 6W
- The bulbs do not generate heat



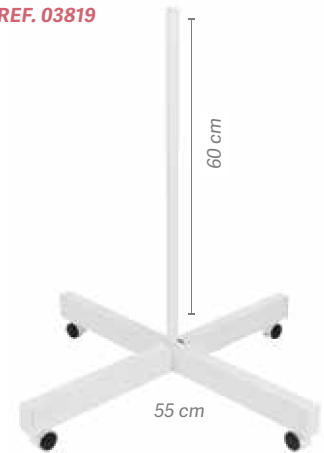

## Pies lupa Feet magnifying glass

**REF. 03820****REF. 03819****REF. 04110**

\* Adaptables a las referencias  
03815, 03816, 03817, 04107, 04108, 04109 y  
04198

\* Adaptable to references  
03815, 03816, 03817, 04107, 04108, 04109  
y 04198

**Limas bolsa individual: recta**  
**Nail files individual bag: straight**

u.m.vta: 12  192 

Peso: 10 g  
 Weight: 10 g

Grueso: 0,6 cm  
 Thickness: 0,6 cm

80/100

150/180

REF.06697

REF.06698

100/180

180/240



REF.06010

REF.06699



**Limas bolsa individual: curva**  
**Nail files individual bag: curved**

Grueso: 0,6 cm  
 Thickness: 0,6 cm

u.m.vta: 12  192 

80/100

150/180

REF.06700

REF.06701

100/180

180/240

REF.06011



REF.06702



**Limas bolsa individual: media luna**  
**Nail files individual bag: halfmoon**

Grueso: 0,6 cm  
 Thickness: 0,6 cm

Peso: 10 g  
 Weight: 10 g

u.m.vta: 12  192 

80/100

REF.06703

150/180

REF.06704

100/180

REF.06012



180/240

REF.06705



**Limas bolsa individual: rocket**  
**Nail files individual bag: rocket**

Grueso: 0,6 cm  
 Thickness: 0,6 cm

u.m.vta: 12  192 

100/180

REF.06013



**Limas bolsa individual: cuadrada**  
**Nail files individual bag: Square**

Grueso: 0,6 cm  
 Thickness: 0,6 cm



u.m.vta: 12  192 

100/180

REF.06014



**Mango metálico para lima**  
**Metal handle for file**

u.m.vta: 1  12 

**REF.07222**

**Recta**  
**Straight**



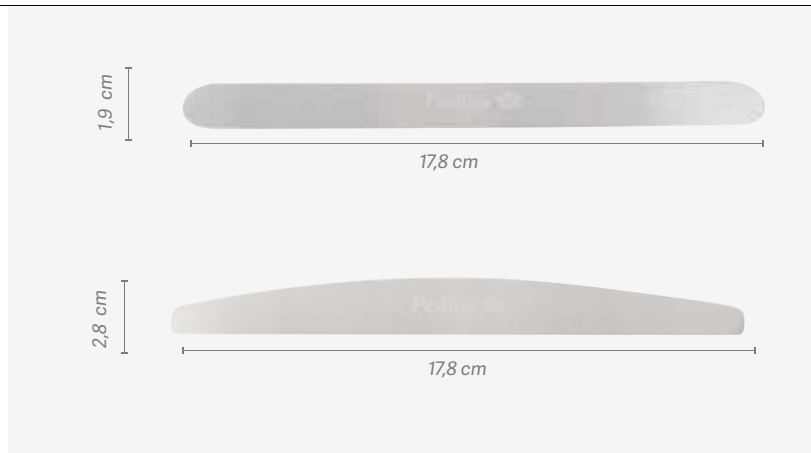

**REF.07223**

**Media luna**  
**Halfmoon**



**Pack 48 recambios lima negra**  
**Pack 48 spare parts black file**

u.m.vta: 1  12 

**Recta**  
**Straight**



**REF.07224**

**Media luna**  
**Halfmoon**

**REF.07225**



**Pack 48 recambios lima blanca**  
**Pack 48 spare parts white file**

u.m.vta: 1  12 

**Recta**  
**Straight**

**REF.07228**

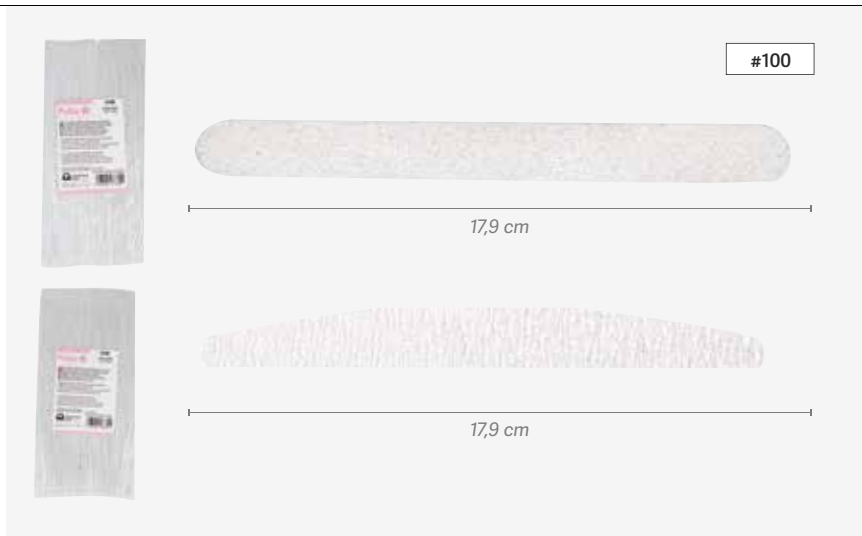

**Media luna**  
**Halfmoon**

**REF.07229**





**Pack 48 recambios lima Zebra**  
**Pack 48 spare parts Zebra file**



u.m.vta: 1  12 

**Recta**  
**Straight**  
**REF.07226**

**Media luna**  
**Halfmoon**  
**REF.07227**



**Limas en pack de 12 UNIDADES**  
**Nail files pack 12 UNITS**

u.m.vta: 1  40 

80/80  
**REF.06020**

100/100  
**REF.06021**

180/180  
**REF.06022**

240/240  
**REF.06023**





400/400  
**REF.06024**

600/600  
**REF.06025**

**Recta**  
**Straight**

Escoge el gramaje que mejor te va  
 Choose the gr ammage that best suits you

**Limas en pack de 12 UNIDADES**  
**Nail files pack 12 UNITS**



u.m.vta: 1  40 

**REF.06000**

**Recta**  
**Straight**

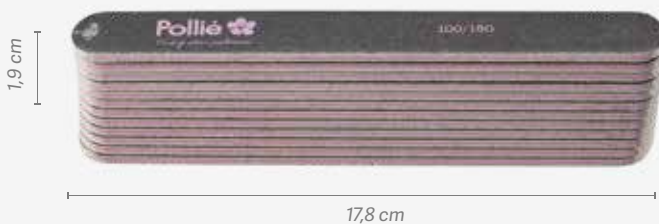
100/180





u.m.vta: 1  40 

**REF.06001**

**Curva**  
**Curved**





u.m.vta: 1  32 

**REF.06002**

**Media luna**  
**Halfmoon**





u.m.vta: 1  28 

**REF.06003**

**Rocket**  
**Rocket**





u.m.vta: 1  32 

**REF.06004**

**Cuadrada**  
**Square**



**Limas bolsa individual zebra**  
**Nail files individual bag zebra**

u.m.vta: 12  192 

**REF.06015** **Recta**  
**Straight**



**REF.06016** **Curva**  
**Curved**



**REF.06017** **Media luna**  
**Halfmoon**



**REF.06018** **Rocket**  
**Rocket**





**REF.06019** **Cuadrada**  
**Square**



**Limas en pack de 12 unidades zebra**  
**Nail files pack 12 units zebra**



Groeso: 0,6 cm  
 Thickness: 0,6 cm

u.m.vta: 1  40 

100/180



**REF.06005**      **Recta**  
**Straight**



u.m.vta: 1  40 



**REF.06006**      **Curva**  
**Curved**



u.m.vta: 1  32 



**REF.06007**      **Media luna**  
**Halfmoon**



u.m.vta: 1  28 

**REF.06008**      **Rocket**  
**Rocket**



u.m.vta: 1  32 

**REF.06009**      **Cuadrada**  
**Square**





**Lima profesional negra acolchada**  
**Padded black professional nail file**

Grueso: 0,3 cm  
 Thickness: 0,3 cm

u.m.vta: 12	300	
-------------	-----	--

**REF.03427**

**Recta**  
**Straight**



**REF.03428**

**Curva**  
**Curved**



u.m.vta: 12	384	
-------------	-----	--

**REF.03429**

**Cuadrada**  
**Square**



**Lima profesional Zebra acolchada 12 UNIDADES**  
**Padded Zebra professional nail file 12 UNITS**

Grueso: 0,3 cm  
 Thickness: 0,3 cm

u.m.vta: 12	480	
-------------	-----	--

**REF.03425**

**Recta**  
**Straight**



u.m.vta: 12	300	
-------------	-----	--

**REF.03424**

**Curva**  
**Curved**

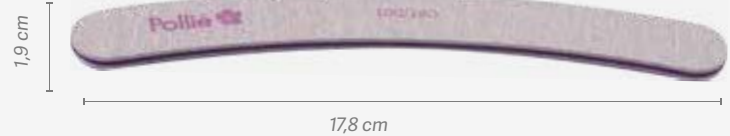

u.m.vta: 12	300	
-------------	-----	--

**REF.03426**

**Cuadrada**  
**Square**





100/180. Lavables y desinfectables. Sistema abrasivo completo y profesional. Extra durabilidad. Lima 2 veces más rápido que las limas normales. Excelente para uñas de gel y acrílicas

100/180 Washable and disinfected. Complete and professional abrasive system. Extra durability. File 2 times faster than normal nail files. Excellent for gel and acrylic nails

**Pack 12 limas súper acolchadas**  
**Pack 12 super padded nail files**

Grueso: 0,8 cm  
Thickness: 0,8 cm

u.m.vta: 1  25 

100/180

**REF.06358**  Zebra **REF.06360**

**Recta**  
**Straight**





**REF.06359**  Zebra **REF.06361**

**Curva**  
**Curved**



**Paquete de 50 limas americanas. Uso profesional**  
**Set of 50 american nail files. Professional use**

Grueso: 0,13 cm  
Thickness: 013 cm

u.m.vta: 1  40 

- Sistema abrasivo completo y profesional
- Extra durabilidad
- Lima 2 veces más rápido que las limas convencionales
- Excelente uso para uñas de gel y acrílico

- Complete professional abrasive system
- High durability
- File 2 times faster than conventional nail files
- Excellent work on gel and acrylic nails

**REF.06812**  Blanco White **REF.06813**

Lima negra 2 lados  
Black nail file 2 ways

Lima blanca 2 lados  
White, nail file 2 ways

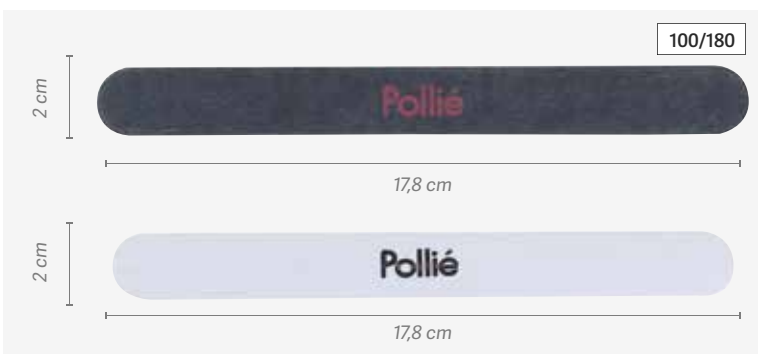



### Limas americanas negra

#### American nail files

Grueso: 0,13 cm  
Thickness: 0,13 cm

u.m.vta: 10  1500



REF.01027



### Pack 12 limas acolchada negra

#### Pack 12 black padded nail files

Grueso: 0,3 cm  
Thickness: 0,3 cm

u.m.vta: 1  40 

REF.01030



REF.01421

### Limas bolsa individual

#### Nail files individual bag

Grueso: 0,4 cm  
Thickness: 0,4 cm

u.m.vta: 12  600



REF.01200



### Pack 12 limas profesionales zebra súper acolchada

#### Pack 12 super padded zebra professional nail files

Grueso: 0,3 cm  
Thickness: 0,3 cm

u.m.vta: 1  40 

REF.03731

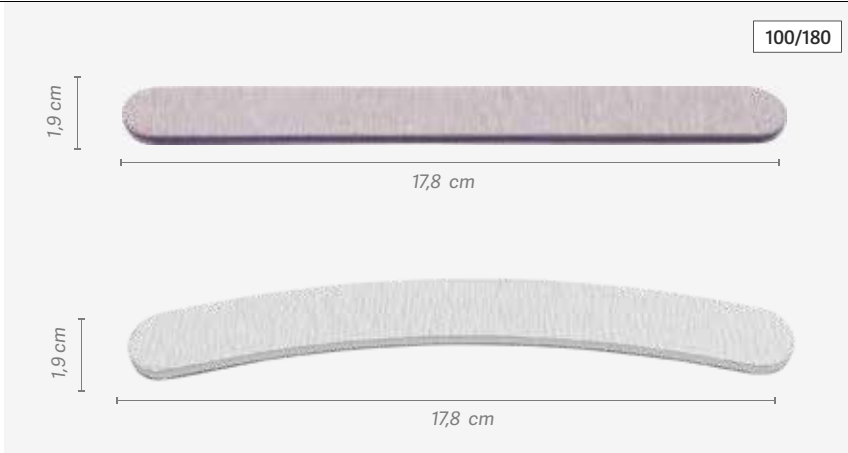

REF.03730

### Bolsa 10 limas de cartón

#### Bag 10 card nail files

Grueso: 0,12 cm  
Thickness: 0,12 cm

u.m.vta: 12  336

**REF.00601**

- Pequeña
- Small

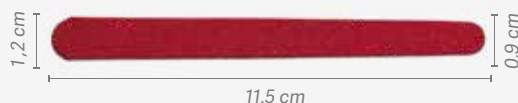

u.m.vta: 12  204

**REF.00602**

- Grande
- Large



### Bolsa 6 limas de cartón

#### Bag 6 card nail files

u.m.vta: 12  756

**REF.01107**

Grueso: 0,3 cm  
Thickness: 0,3 cm



### Juego 20 limas r.601-602 (10 + 10)

#### Set 20 nail files r.601-602 (10 + 10)

Grueso: 0,1 cm  
Thickness: 0,1 cm

u.m.vta: 12  120

**REF.00621**

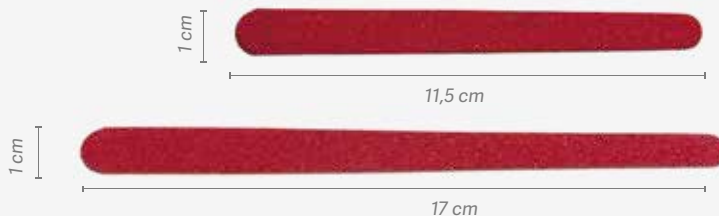

### Bolsa 5 u. lima americana roja

#### Bag 5 u. nail file red

Grueso: 0,12 cm  
Thickness: 0,12 cm

u.m.vta: 12  216

**REF.01517**

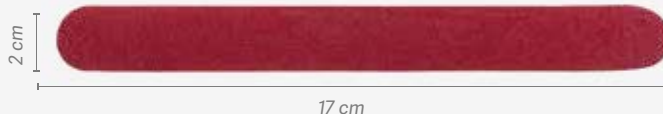

### Paquete 10 limas, granel

#### 10 nail files, in bulk

Grueso: 0,12 cm  
Thickness: 0,12 cm

u.m.vta: 12  336



**REF.01116**

- Pequeña
- Small



**Bolsa 5 limas colores variados**  
**Bag 5 nail files assorted colours**

Gueso: 0,6 cm  
 Thickness: 0,6 cm

u.m.vta: 12  60 



180

REF.06367

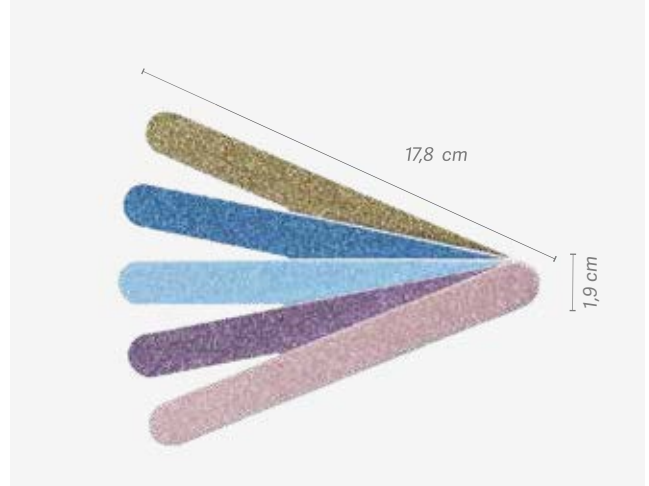
- Una cara purpurina, la otra gramaje 180
- One face glitter, the other grammage 180



**Bolsa 5 limas estampadas**  
**Bag 5 printed nail files**



u.m.vta: 12  60 

180/240

REF.06365

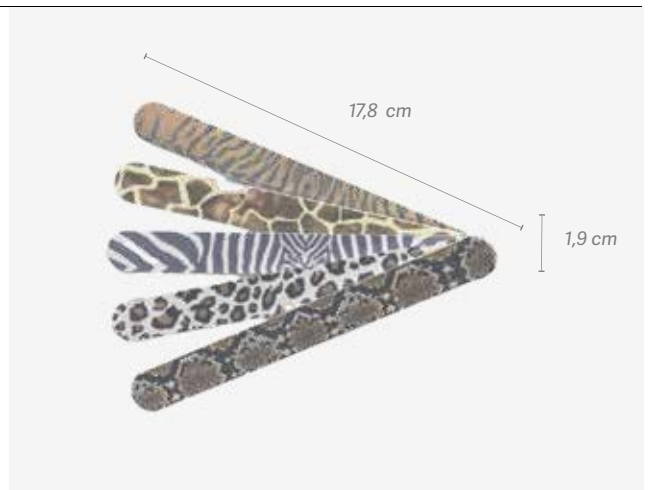
- Estampado animales
- Animal print, gammage



u.m.vta: 12  60 

180/240

REF.06366

- Estampado variados
- Various prints

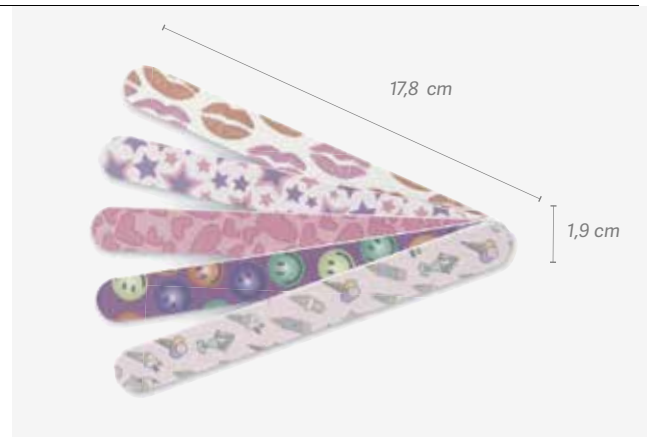

Gueso: 0,6 cm  
 Thickness: 0,6 cm



**Manicuras perfectas**  
**CON COLOR**

**Perfect manicures**  
**WITH COLOUR**

### Expositor de 42 limas Display of 42 nail files

u.m.vta: 1  20 



180

REF.06416

- 6 modelos x 7 unidades.
- Una cara purpurina, la otra lima de gramaje 180
- Colores surtidos
- 6 models x 7 units.
- A glitter face, the other file with a grammage of 180
- Various colors



### Expositor de 48 limas Display of 48 nail files

u.m.vta: 1  20 



180/240

REF.06415

- 6 modelos x 8 unidades
- Estampado animales
- 6 models x 8 units
- Animal print



### Expositor de 48 limas estampadas Display of 48 printed nail files

u.m.vta: 1  20 

180/240

REF.06414

- 6 modelos x 8 unidades
- Estampado variados
- 6 models x 8 units
- Various prints



### Lima pulir brillo Brightness Polish nail file

Grueso: 0,3 cm  
Thickness: 0,3 cm

u.m.vta: 12  360



**REF.01029**

- 4 usos
- 4 uses



### Limas bufer de 3 caras 3 face buffer nail file

3 usos  
3 uses

u.m.vta: 12  240 

**REF.06363**



**Gramajes:**

- Parte rosa : 320
- Parte blanca: 600
- Parte gris: 4000

**Grammajes:**

- Pink part : 320
- White part: 600
- Grey part: 4000



u.m.vta: 12  84 

**REF.06362**

**Gramajes:**



- Parte rosa : 320
- Parte blanca: 600
- Parte gris: 4000

**Grammajes:**

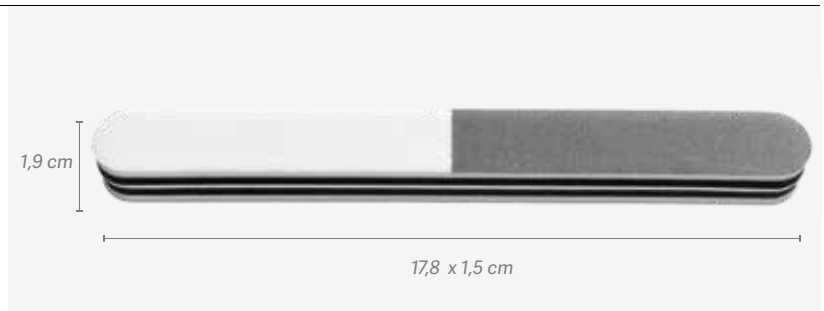
- Pink part : 320
- White part: 600
- Grey part: 4000



### Lima roja pulidora media luna con bolsa Half-moon nail polishing file with a bag



u.m.vta: 12  60 

**REF.06706**

100/180



### Lima roja pulidora con bolsa Red nail polishing file

u.m.vta: 12  144 

**REF.06712**

80/80





**Lima rectangular pulir**  
**Rectangular nail polish file**

u.m.vta: 12  120

**REF.01380**



**Lima bloque 4 caras**  
**Block 4 sides nail file**



u.m.vta: 12  216 

240/320/400/4000

**REF.06029**



**20 limas bloque 3 caras**  
**Block 20, 3 sides nail files**

u.m.vta: 1  46 

- Lila
- Purple

- Naranja
- Orange



80/80/100

100/100/180

**REF.06030**

**REF.06031**





u.m.vta: 1  56 

120

**REF.06032**

- Blanca
- White



u.m.vta: 12  216 

120

**REF.06028**

- Blanca
- White





## Caja de 50 tacos mini bloque

### Box of 50 mini blocks

u.m.vta: 1

120



120/120

REF.06708

El taco pulidor de dos caras con su granulado de 120 es la lima idea para igualar las grandes superficies, ya sea sobre uñas naturales o postizas.

*The two-sided polishing block with its 120 grit is the idea file for large surfaces, whether natural or false nails.*

- 2 caras
- color blanco

- Two-sided
- White



## Bolsa de 6 tacos mini bloque

### Bag of 6 mini blocks

u.m.vta: 12

192



120/120

REF.06707

- 2 caras
- Color blanco

- Two-sided
- White



## Limas cristal

### Glass nail files

u.m.vta: 1

12



Lila  
Lilac

REF.06630/68

Rosa  
Pink

REF.06630/70

- 2 caras
- 2 sides

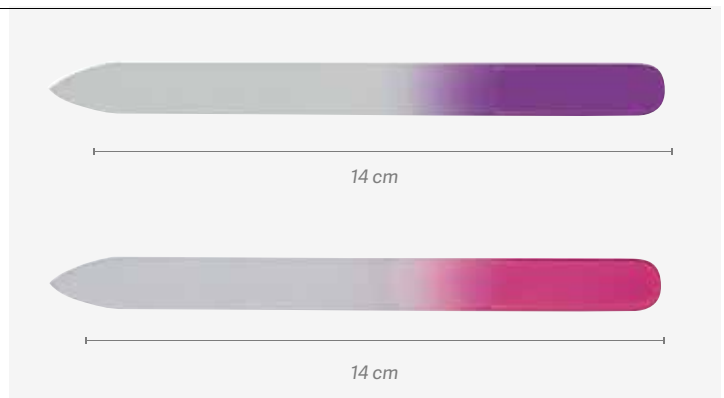

### Lima Saphire con mango

#### Sapphire nail file with handle

u.m.vta: 12  300

REF.00841



REF.00842



REF.00843



REF.00844



REF.00845



### Cojín apoyamanos blanco

#### White support cushion

u.m.vta: 1  50

REF.04969

- Para que las manicuras sean más cómodas tanto para el cliente como para el esteticista
- So that manicures are more comfortable both for the client as for beautician



### Esterilizador calor seco Sanity Security Sterilizer hot dry Sanity Security

u.m.vta: 1  1

REF. 03011

- Potencia: 400W
- 230° C
- Voltaje: 220-240V~
- Frecuencia: 50 Hz
- Temperatura regulable 20 a 200°

- Power: 400W
- 230°C
- Voltage: 220-240V ~
- Frequency: 50 Hz
- Adjustable temperature from 20 to 200°



### Esterilizador Germicida GX4 Germicidal GX4 sterilizer

u.m.vta: 1  1

REF. 03009/59

- Potencia: 15W
- Ultra plano
- Luz germicida alta calidad

- Power: 15W
- Ultra flat
- High quality germicide light



**Lerioti**  
MADE IN ITALY
u.m.vta: 1  20

REF. RE00891/01



Recambio bombilla UV  
Bulb replacement UV lamp

### Esterilizador GX7 naranja Orange GX7 sterilizer

u.m.vta: 1  1

REF. 03010/64

- Potencia: 75W
- Capacidad 120 cc
- Con esferas de cuarzo
- Voltaje: 220-240V~
- Frecuencia: 50 Hz

- Power: 75W
- Capacity 120 cc
- With quartz spheres
- Voltage: 220-240V ~
- Frequency: 50 Hz



### Recambios Spare parts



- Bolsa recambio esferas de cuarzo
- 50/60 bolas por bolsa
- Peso 160g aprox

- Bag replacement quartz
- 50/60 balls per bag
- Weight 160g approx

REF. RE03010/64/01

### Esterilizador EUROSTIL

#### EUROSTIL sterilizer

u.m.vta: 1  6 

**REF. 07013**



- De cuarzo
- Ideal para utensilios como tijeras
- Incluye una bolsa de esferas
- No apto para materiales plásticos

- Of quartz
- Ideal for tools as scissors
- Includes a bag of spheres
- Not suitable for plastic materials



### Bote esferas de cuarzo

#### Steriliser quartz spheres

u.m.vta: 1  12 

500 g



**REF. 06619**

Para esterilizar herramientas metálicas tanto de peluquería como de estética

To sterilize metal tools for both hairdressing and aesthetics

### Esterilizador UV Eurostil plástico

#### Eurostil plastic UV sterilizer

u.m.vta: 1  1 

**REF. 06618**

Esterilizador de rayos ultravioleta para todo tipo de herramientas tanto de peluquería como de estética

- Potencia 8W

Ultraviolet ray sterilizer for all types of tools, both hairdressing and aesthetics

- Power 8W





u.m.vta: 1  1

**REF. RE06618/01**

Recambio bombilla UV  
Bulb replacement UV lamp



### Alicate corta cutículas Cuticle nipper

u.m.vta: 1  10 

Encaje muelle boca 5,5 mm  
Mouth 5,5 mm

**REF. 04659**



La gama de productos PREMIUM de Pollié está diseñada y fabricada para satisfacer al máximo sus necesidades. Fabricados con acero inoxidable. Pollié Premium ofrece la mejor calidad y rendimiento en sus nuevos alicates para uñas y cutículas, los últimos pasos de su fabricación se hacen a mano para conseguir el alicate perfecto.

*The PREMIUM product range by Pollié has been designed and manufactured to satisfy your needs to the utmost. Made from stainless steel. Pollié Premium offers the finest quality and performance in its nail and cuticle clippers, and the last steps in the manufacturing process are carried out by hand in order to produce the perfect clipper.*

Encaje muelle boca 4,5 mm  
Mouth 4,5 mm

**REF. 04660**





Encaje simple boca 5,5 mm  
Mouth 5,5 mm

**REF. 04661**



### Alicate cortaúñas Nail clipper

u.m.vta: 1  50 

Encaje simple  
Simple lace

**REF. 04663**



**Alicate corta cutículas azul titanio**  
**Cuticle nipper titanium blue**

u.m.vta: 1  12

**REF.03243**



10 cm

**REF.03244**



10 cm

**REF.04697**



11 cm

**REF.03245**



12 cm

**Alicate corta cutículas**  
**Cuticle nipper**

u.m.vta: 1  12

Con cierre  
 With lock

**REF.01275**



11 cm



## Alicate corta cutículas Cuticle Nipper

u.m.vta: 1	 12
------------	--

Encajado  
W/lock

**REF.02125**



8 cm

Boca 5 mm  
Mouth 5 mm

**REF.04692**



10 cm

**REF.01272**



10 cm

**REF.03688**



11 cm

**Alicate cutículas**

**Cuticle nipper**

u.m.vta: 1  1

Acero al carbono  
Carbon Steel

**REF.02264**

Muelle recambio +  
tornillo alicate  
Nippers double  
spring + screw

**REF.02404**

Extrafino  
Acero inoxidable  
Superfine  
Stainless steel

**REF.02679**

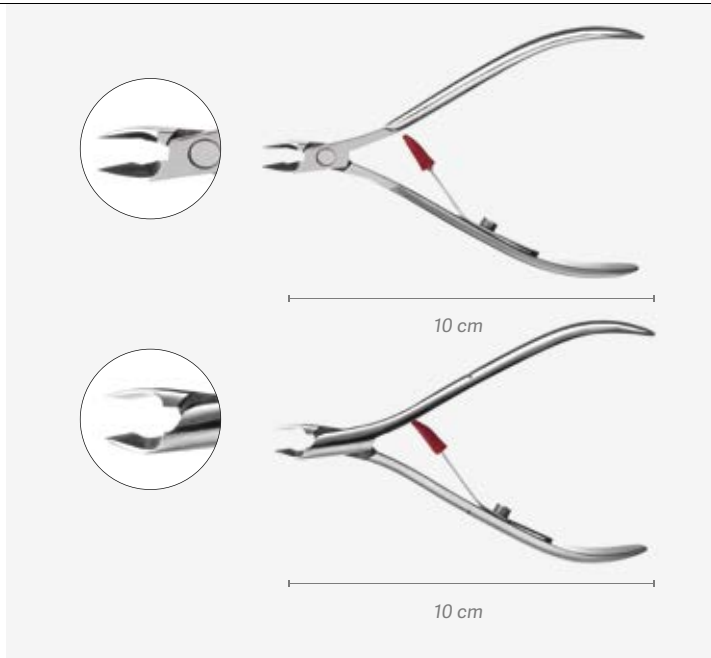

u.m.vta: 1  12

Mango satinado  
Glossy handle

**REF.02812**

Redondo. Boca 3 mm  
Round. Mouth 3 mm

**REF.03018**

Redondo. Boca 5 mm  
Round. Mouth 5 mm

**REF.03019**

Boca 4 mm  
Mouth 4 mm

**REF.03039**

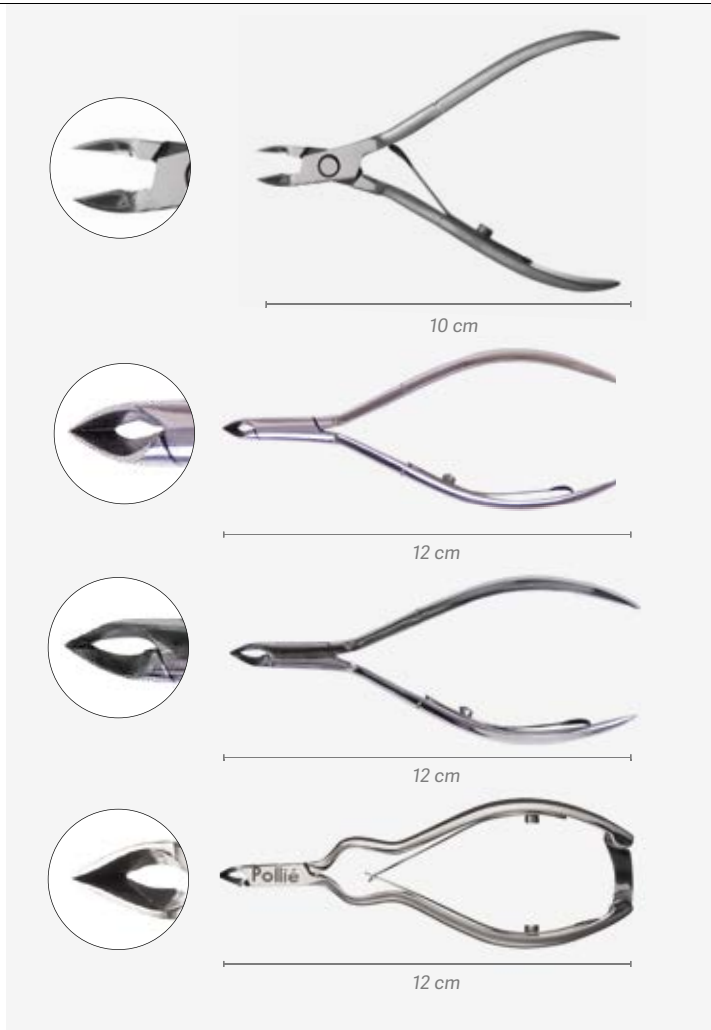

### Alicate corta cutículas Acero Quirúrgico

#### Cuticle nipper Surgical steel

u.m.vta: 1  1

**REF.02265** Boca 2 mm encajada  
Mouth 2 mm

**REF.02266**

Boca 4 mm encajada  
Mouth 4 mm

**REF.02267**

Boca 6 mm encajada  
Mouth 6 mm

**REF.02405**

Muelle recambio + tornillos para alicate  
02265 - 02266 - 02267  
Nippers double spring + screw 02265 -  
02266 - 02267

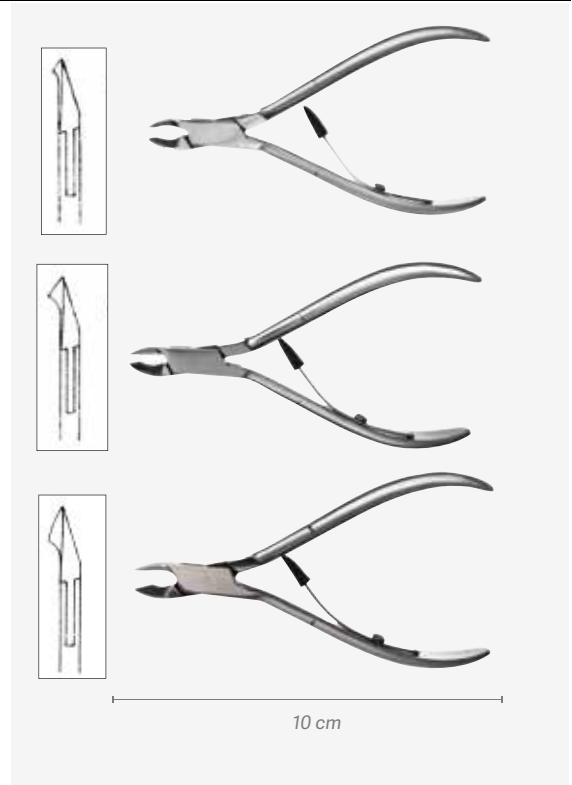

### Alicate corta cutículas Acero inoxidable

#### Cuticle nipper Stainless steel

u.m.vta: 1  12

Boca 3 mm  
Mouth 3 mm

**REF.03685**

Boca 4 mm  
Mouth 4 mm

**REF.03686**

Boca 5 mm  
Mouth 5 mm

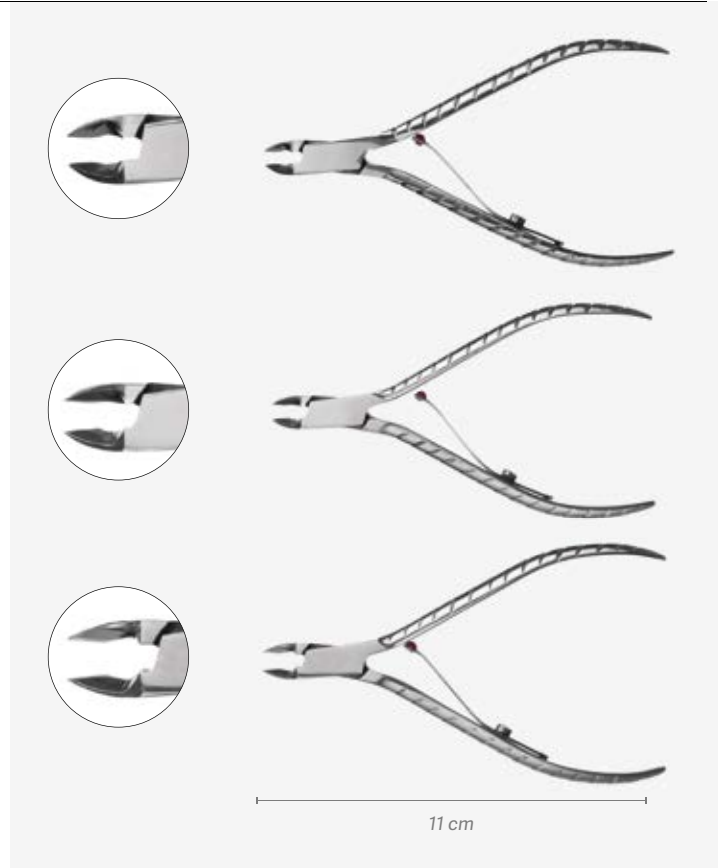
**REF.03687**

**Alicate cortaúñas**  
**Nail clipper**

u.m.vta: 1  12

**REF.01271** Acero inoxidable  
Stainless steel



10 cm

**REF.02813** Satinado  
Glossy



10 cm

**REF.04693**



11 cm

**REF. 01276** Satinado  
Glossy



12 cm

**REF.03240** Azul titanio  
Titanium blue



10 cm

**REF.04696** Con muelle interior  
Azul titanio  
With inner spring  
Titanium blue



11 cm

## Alicate corta cutícula

### Cuticle nipper

u.m.vta: 12	 12
-------------	--

Blanco  
White

**REF.01069**



Blanco con lima  
White, with nail file

**REF.02836**



**REF.01336**



Lila con goma  
Lilac with rubber

**REF.04411**



Colores con goma  
Colours with rubber

**REF.01037**



Lila con goma  
Lilac with rubber

**REF.04589**



## Cortaúñas

### Nail cutter

u.m.vta: 12  12

- Pequeño
- Small

REF.01064



- Grande
- Large

REF.01038



## Cortaúñas con depósito

### Nail cutter with canister

u.m.vta: 12  120

- Pequeño
- Small

REF.04408



- Grande
- Large

REF.04407



## Alicate cortaúñas artificiales

### False nails clipper

u.m.vta: 1  12

REF.01476



## Set de manicura 6 piezas completo

### Manicure set 6 tools

u.m.vta: 1  1

REF.02746



## Estuche con 11 utensilios manicura

### Set with 11 manicure tools

u.m.vta: 1  1

REF.04882

- Capacidad para 20 utensilios
- Capacity for 20 tools





**Funda alicates pieles y cortaúñas**  
**Cover cuticle & nail cutter**

u.m.vta: 1  10

REF.02402

- Pequeño
- Small



u.m.vta: 1  10

REF.02403

- Grande
- Large



**Funda alicates y cortaúñas, negra**  
**Cover nipper & nail cutter, black**

u.m.vta: 1  10

REF.02512



- Acero esterilizable
- Sterilisable steel

**Funda pinzas, limas pequeñas y tijeras**  
**Cover tweezers, small nail files & scissors**

u.m.vta: 1  10

REF.02401



**Porta gubía**  
**Gouge handle**

u.m.vta: 1  48

REF.02820



**12 Gubías en blíster individual**  
**12 Sterile gouge blades**

u.m.vta: 1  10

Nº1  
 REF.02821



Nº2  
 REF.02822



Nº3  
 REF.02823



Nº4  
 REF.02824



Nº5  
 REF.02825



Nº6  
 REF.02826



Nº8  
 REF.02827



Nº10  
 REF.02828



Nº12  
 REF.02829



## ¿Cómo preparar la uña para el esmalte? How to prepare nails for polishing?

- Esterilizar siempre las herramientas de manicura que se vayan a utilizar
- Limar y dar forma a la uña, al gusto del cliente e igualarlas
- Humedecer la uña con agua
- Empujar las cutículas con un empujador o palito de naranjo
- Retirar las pieles con un alicate especial para pieles de manicura
- Pasar una lima de pulir para dejar la uña sin grasa y sin brillo
- Humedecer la uña de nuevo y secarla

- Always sterilise any manicure tools you intend to use
- Trim and file the nail to the client's taste and even them out
- Dampen the nails with water
- Push back the cuticle with a cuticle pusher or a manicure stick
- Remove skins with special manicure skin pliers
- File slightly with a polishing file in order to remove all oil and shine from the nail
- Dampen the nail once again and dry it



### Doble empujador cutículas acero inoxidable Stainless steel double cuticle pusher

u.m.vta: 1	12
------------	----

REF.04104



u.m.vta: 1	24
------------	----

REF.04688

u.m.vta: 1	24
------------	----

REF.04689

### Empujador cutículas acero inoxidable Stainless steel cuticle pusher

u.m.vta: 1	24
------------	----



REF.04687



u.m.vta: 1	12
------------	----

REF.04105

**Cepillo uñas**  
**Nail brush**

u.m.vta: 1  12 



Rosa con mango  
Pink with handle

REF.06753

Blanco con mango  
White with handle

REF.06754



u.m.vta: 1  50 



REF.00132

Grande, dos caras  
Large, two faces





u.m.vta: 24  24



REF.02185

Doble especial  
Double





u.m.vta: 12  120 



REF.00774

Con asas grande  
With handle, large



u.m.vta: 12  120 



REF.00792

Con asas, pequeño  
With handle, small



**Bol acero inoxidable manicura**  
**Stainless steel manicure bowl**



u.m.vta: 10  120

325 ml

REF.03732



**Bol especial manicura**  
**Special manicure bowl**

u.m.vta: 1  18 

REF. 00889





**Bol moja dedos color natural, ergonómico**  
**Ergonomic manicure bowl in natural colour**

u.m.vta: 20  20

REF.03399



**Tijera nariz y oreja punta redonda**  
**Round point ear and nose scissors**



u.m.vta: 1  12 

4"

REF.07087



**Tijera bebé punta roma**  
**Baby scissors point roma**



u.m.vta: 1  12 

3.5"

REF.07088



**Pinza piching 3 en 1**  
**3 In 1 pinching tweezers**

u.m.vta: 1  10 

REF.07090



**Tijera profesional recta para pieles**  
**Professional straight cuticle scissors**

u.m.vta: 1  30

3.5"

REF.07353



**Tijera profesional recta para uñas**  
**Professional straight nail scissors**



u.m.vta: 1  30

3.5"

REF.07354





**Tijera curvada Pieles**  
**Cuticle curved scissors**

u.m.vta: 1  12 



**REF.07085**



u.m.vta: 1  12 

**REF.04690**



u.m.vta: 1  12 

**REF.01270**

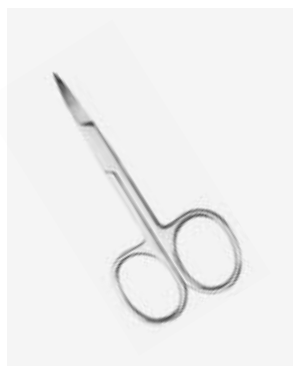

u.m.vta: 1  30

**REF.01989** Profesional  
 Professional

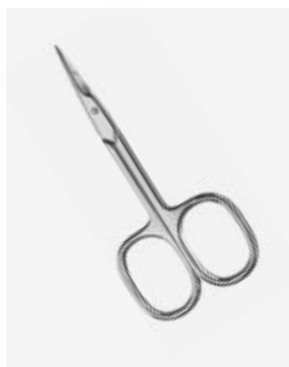



u.m.vta: 1  12

**REF.03419**

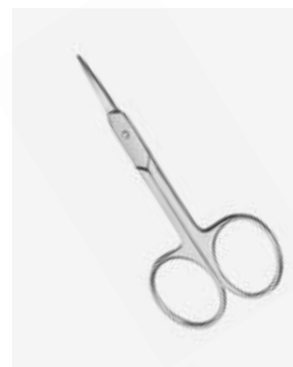
Punta fina  
 Curved thin tip



**Tijera curvada uñas**  
**Nail curved scissors**

u.m.vta: 1  12 

**REF.07086**

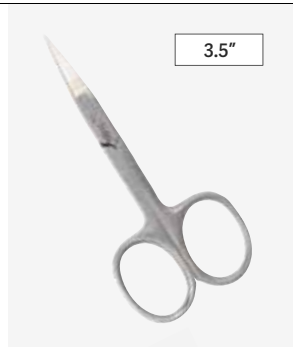

**REF.01269**





u.m.vta: 1  30

Profesional  
 Professional

**REF.01990**



u.m.vta: 1  12 

**REF.04691**

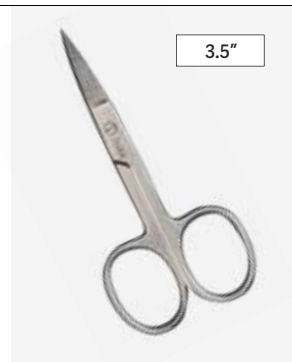

**Bolsa baja pieles**  
**Bag orange sticks**

u.m.vta: 10  10

**REF.06567**



10 u

- Madera
- Wooden

u.m.vta: 10  10

**REF.01279**



10 u

- Madera
- Wooden

u.m.vta: 10  10

**REF.02716**





u.m.vta: 50  50

**REF.00121**



50 u

- Plástico
- Plastic



u.m.vta: 1  10 

**REF.06565**



100 u

- Madera
- Wooden



u.m.vta: 1  10 

**REF.06566**



100 u

- Madera
- Wooden

u.m.vta: 1  80 

**REF.00123**



100 u

- Madera
- Wooden

u.m.vta: 1  10

**REF.04525**



1000 u

**REF.04526**





**Alicate cortaúñas pedicura**  
**Pedicure nail clipper**

u.m.vta: 1  12

**REF.03017**

Mango satinado  
Acero inoxidable  
*Satin handle*  
*Stainless steel*



12 cm

**REF.01475**

Con cierre, acabado  
brillante  
*With lock, glossy*



12 cm

**REF.03016**

Mango satinado  
Acero inoxidable  
*Satin handle*  
*Stainless steel*



14 cm

**REF.01474**

Con cierre, acabado  
brillante  
Acero inoxidable  
*With lock, glossy*  
*Stainless steel*



14 cm

u.m.vta: 1  10

**REF.04695**

Mate con cierre  
*Matt with lock*



12 cm

**REF.04694**



Mate, con cierre  
*Matt with lock*



14 cm

### Alicate cortaúñas pedicura

#### Pedicure nail clipper

u.m.vta: 1  10 

**REF.07089**

Recta doble con  
muelles  
*Straight double with  
springs*



14 cm

**REF.07136**

Oblicua con  
muelles  
*Oblique with  
springs*



14 cm

### Cortaúñas pedicura azul titanio

#### Pedicure nail clipper titanium blue

u.m.vta: 1  12

**REF.03241**

Con cierre  
*With closure*



12 cm

**REF.03242**

Con cierre  
*With clousure*



14 cm

### Alicate podólogo articulado

#### Nail clipper articulated pedicure

u.m.vta: 1  1

**REF.02271**



15 cm

**Bol acero inoxidable pedicura**  
**Stainless steel pedicure bowl**

u.m.vta: 1  10

7 L

REF.03733



**Bolsa separadedos pedicura**  
**Bag pedicute separators**



u.m.vta: 50  50

REF.00846

- 2 unidades
- Pedicuras
- Blanco

- 2 units
- Pedicuras
- White



u.m.vta: 1  12 

REF.06755

- 2 unidades
- Silicona

- 2 units
- Silicone



**Raspacallos**  
**Scrape calluses**

u.m.vta: 1  24

REF. 04810



**Recambios**  
**Spare parts**

**Bolsa 2 limas**  
**2 files bag**

REF. RE04810/01

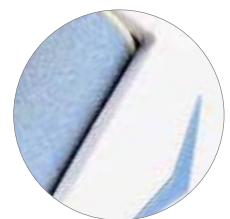

Este raspacallos es un innovador dispositivo creado para suavizar la piel seca, áspera y los callos de los pies. Su rodillo gira 360 grados a una velocidad de 40 veces por segundo. Trabaja más rápido y es más seguro que los raspacallos convencionales. Está diseñado para suavizar la piel gruesa en los pies y los talones. Con pilas

*This scrape calluses is an innovative device created to soften dry, rough skin and calluses on the feet. Its roller rotates 360 degrees at a speed of 40 times per second. It works faster and is safer than conventional scrape calluses. It is designed to soften the thick skin on the feet and heels. With batteries.*

### Crema TASSEL pies TASSEL feet cream

u.m.vta: 1  12

400 ml

- Hidratante intensiva
- Intensive moisturizer

REF.06430

### Exfoliante TASSEL pies TASSEL feet scrub



u.m.vta: 1  12

400 ml

- Con hueso de albaricoque
- Peeling with apricot kernel

REF.06431

### Ablandador líquido de durezas y callos Liquid callus and corn softener

u.m.vta: 1  12 

500 ml

REF.04811

Gracias al líquido ablandador Pollié es más fácil retirar los callos y las durezas para lucir unos pies jóvenes y cuidadosos.

*Our Pollié liquid softener makes removing corns and calluses easier, providing you with neat and youthful feet.*



06430



06431



**Raspacallos pedicura**  
**Corn scrapper pedicure**

u.m.vta: 1	 48	
------------	--	---

**REF.06033**

- Plástico (lavables)
- Plastic (washable)

**REF.06034**

- Plástico (lavables)
- Curvo
- Plastic (washable)
- Curved

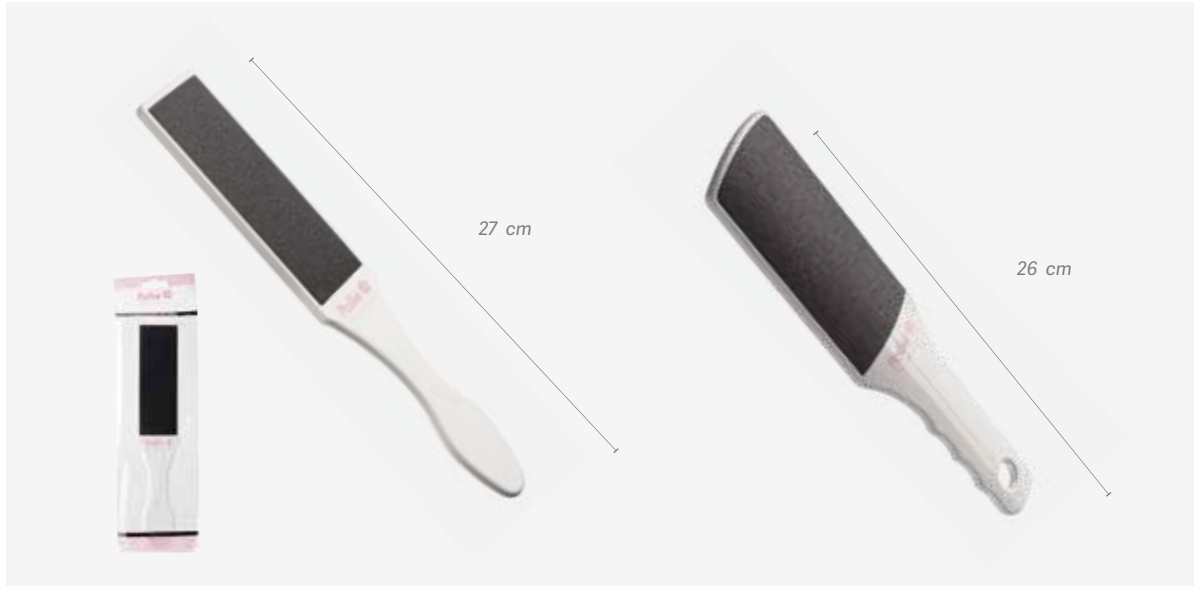

u.m.vta: 12	 12
-------------	--

**REF.01068**

- Metálico
- Metallic



u.m.vta: 1	 30
------------	--

**REF.04416**

Raspacallos transparente de plástico rígido y resistente. Lima de cerámica de doble cara

*Transparent corn scrapper pedicure made of rigid and resistant plastic. Double sided ceramic nail file*





## Raspacallos pedicura Corn scrapper pedicure

u.m.vta: 12  120

**REF.04592**

- Plástico, grande
- Plastic, large





u.m.vta: 1  100 

**REF.01073**



## Raspacallos metálico pedicura con mango de goma soft Metallic corn scrapper pedicure with soft rubber handle

u.m.vta: 1  12 



**REF.06606/58**



**REF.06606/70**



**Raspacallos Podorape doble cara lavable**  
**Double-sided Podorape corn scrapper washable**

u.m.vta: 1	 12	
------------	--	---

REF.06611/58

REF.06611/59



REF.06611/70



Raspacallos Podorape blanco, azul y rosa de doble cara, una fuerte y otra suave. Lavable con mango irrompible, pensado para podólogos, ultra resistente y de uso ideal para personas diabéticas debido a la efectividad y la seguridad del grano.

White, blue and pink Podorape corn scrapper, double sided, one strong and another soft, washable with unbroken handle, designed for chiropodists, ultra-resistant and ideal for diabetic people due to the effectiveness and safety of grain

**Raspacallos pedicura**  
**Pedicure corn scrapper**

u.m.vta: 1	 12	
------------	--	---

REF.06709

- Material: acero inoxidable
- Con mango metálico
- Material: stainless steel
- With metal handle

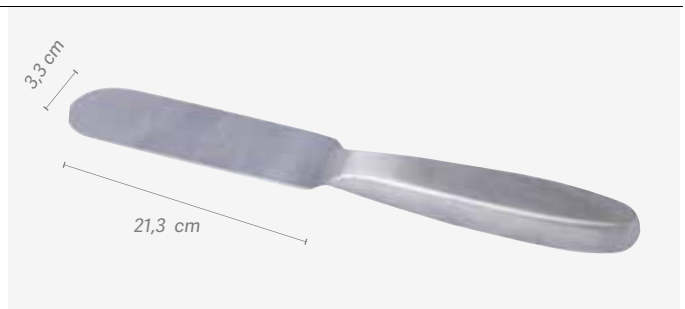

**50 papeles para raspacallos**  
**50 scrapper papers**

u.m.vta: 1	 48	
------------	--	---

80



REF.06710

180

REF.06711



**Piedra pómez**  
**Pumice stone**

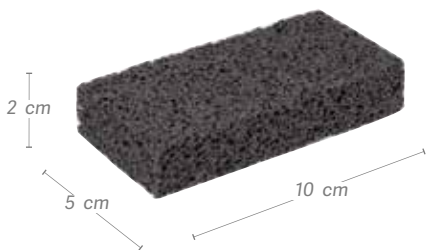

u.m.vta: 1  48 

**REF. 06518**



- Negra pequeña
- Con estructura de poros abiertos



- Pumice stone black small
- with structure of open pores

u.m.vta: 1  48 

- Blanca, pequeña
- White, small

**REF. 06517**





u.m.vta: 1  60 

- Coloreada grande
- Coloured large

**REF. 00942**



u.m.vta: 1  60 

- Colores surtidos
- Assorted colours

**REF. 02757**

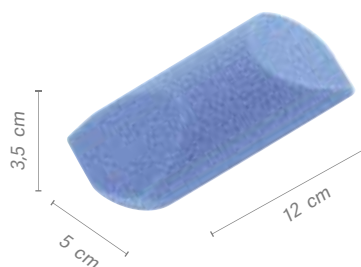

**Piedra pómez con asa**  
**Pumice stone with handle**

u.m.vta: 20  60

**REF.03061**



u.m.vta: 20  60

**REF.03062**

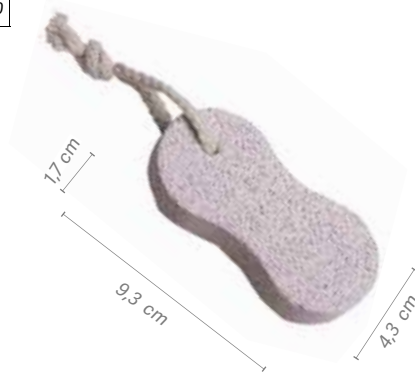

u.m.vta: 10  30

- Pez
- Fish

**REF.03063**



u.m.vta: 20  60





- Ovalada
- Oval

**REF.03065**



## Corta callos



### Corn cutting

u.m.vta: 12	 12	u.m.vta: 12	 12	u.m.vta: 1	 12	
<b>REF.01102</b>	<ul style="list-style-type: none"> <li>• Con cuchilla incluida</li> <li>• With blade included</li> </ul>	<b>REF.01400</b>	<ul style="list-style-type: none"> <li>• Mango plástico</li> <li>• Sin cuchilla</li> <li>• Plastic handle</li> <li>• Blade not included</li> </ul>	<b>REF.01401</b>	<ul style="list-style-type: none"> <li>• Metálico inoxidable</li> <li>• Sin cuchilla</li> <li>• Stainless metallic</li> <li>• Blade not included</li> </ul>	



## Dispensador 100 hojas para corta callos Pollié

### Dispenser 100 sheets for Pollié corn cutting

u.m.vta: 1	 100	
72 g	<ul style="list-style-type: none"> <li>• Medidas caja de 100 ud: 13 cm x 7 cm x 1 cm</li> <li>• Peso: 72g</li> <li>• Medidas hoja: 2,24 cm x 0,01cm</li> <li>• "Made in Germany"</li> <li>• Measurements of the box containing 100 pcs: 13 cm x 7cm x 1 cm.</li> <li>• Weight: 72g</li> <li>• Size of the blade. 2.24 cm x 0.01cm</li> <li>• "Made in Germany"</li> </ul>	

Hojas de recambio de acero para cortacallos. De superficie plana y muy fina. Hojas de calidad con garantía de corte y con seguridad para eliminar el exceso de callos y/o duricias en los pies, gracias a su hoja de precisión, de dos caras y bordes de corte fino. Se adaptan a todos los cortacallos estándar.

Replacement blade sheets for corn cutting. Flat and very thin surface. Quality blades with guarantee of safe cutting to eliminate excess of calluses and/or hardnesses on the feet, thanks to its precision blade, two-sided and fine cut edges. They adapt to all the standard corn cutting.

## Masaje reflexo

### Reflexo massage

u.m.vta: 1		4
------------	---	---

REF. 04809

- Bañera spa masaje pies
- Potencia: 60W
- Masaje vibratorio y de burbujas
- Plantilla de goma antideslizante

- Spa bath massage feet
- Power: 60W
- Vibrating and bubble massage
- Anti-slip rubber insole

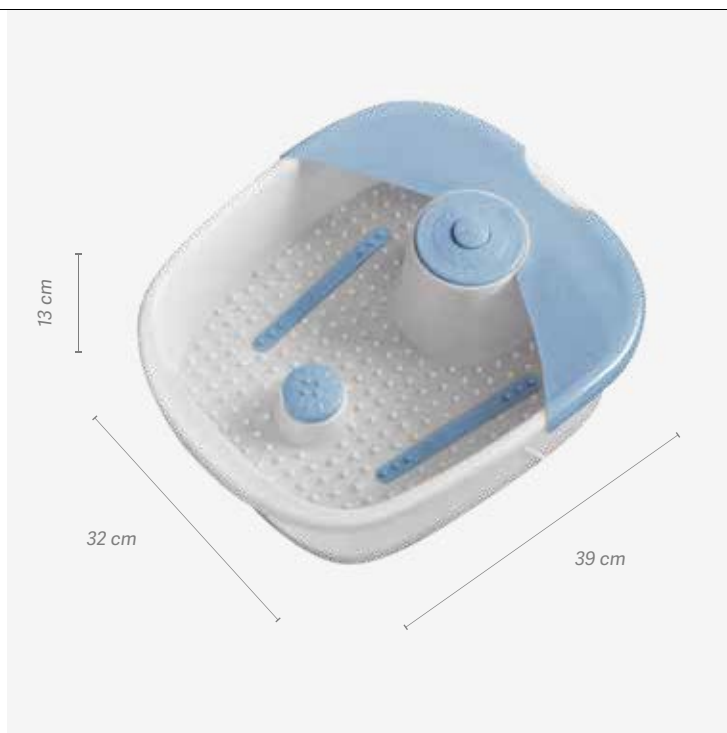

## Masaje reflexo

### Reflexo massage

u.m.vta: 1		2
------------	---	---

REF. 04588

- Potencia: 60W
- Relajante masajeador de pies
- 3 en 1: calentamiento de agua, burbujas y vibración
- Intensa reflexología podal, apego masaje incluido
- Con desagüe para un vaciado más fácil
- Adecuado para pies hasta talla 44. Antideslizante
- Función de calor automático
- Longitud de cable de conexión 175 cm

- Power: 60W
- Relaxing foot massage device
- 3 in 1: water heating, bubbles and vibration
- Intense foot reflexology, including massage
- Includes a drain for easy draining
- Suitable for feet up to size 44. Anti-slip
- Automatic heat function
- The connection cable is 175 cm long





MEDISANA®

**AQUATHERM: 3 EN 1**  
**AQUATHERM: 3 IN ONE**u.m.vta: 1  2**REF. 02309**

- Potencia: 390W
- 3 en 1: masaje por vibración y burbujas con calor infrarrojo
- Calentamiento del agua ajustable desde 20°C a 48 °C
- Temporizador: 20/30/40/50/60 minutos
- En pantalla se muestran el tiempo y la temperatura del agua
- Funciones automáticas de luz infrarroja y calor
- Rodillos de masaje para masajear la parte interna de los pies
- Salidas de aire colocadas ergonómicamente
- Rodillos de masaje de la base desmontables
- Carcasa externa de doble grosor para mantener calor
- Reflexología podal intensa
- Para pies hasta talla 46
- Medidas: 38,6 x 24,3 x 45,9 cm

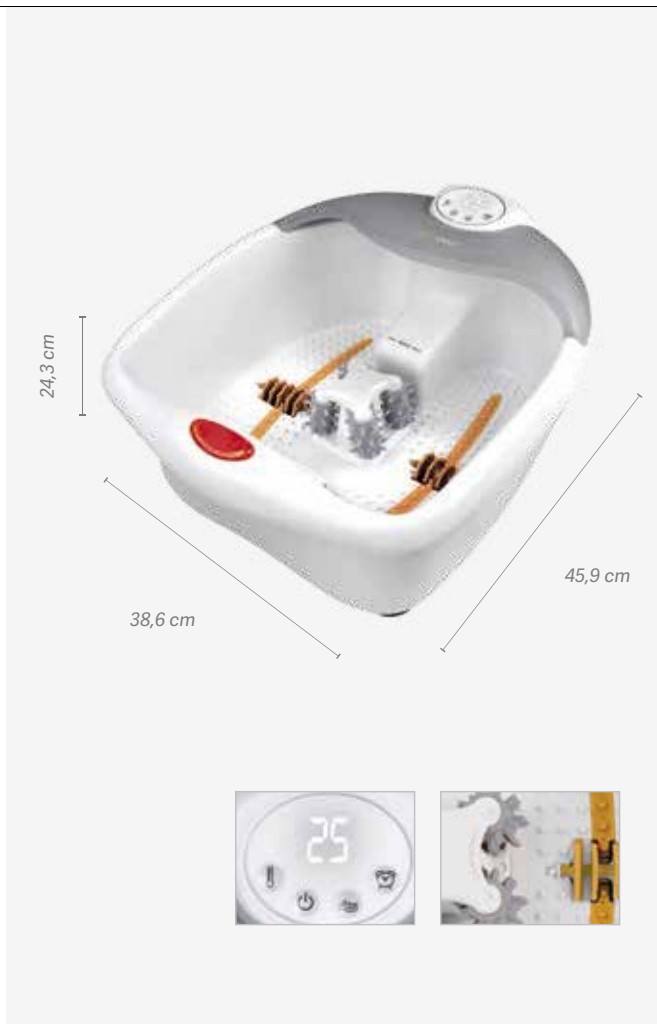
- Power: 390W
- 3 in 1: vibration massage, bubbles and infra-red heat
- Adjustable water heating from 20 °C to 48 °C
- Timer: 20/30/40/50/60 minutes
- The timer and water temperature are displayed on the screen
- Automatic infra-red light and heat functions
- Massage rollers to massage the inside of the feet
- Ergonomically placed air vents
- Massage rollers with detachable bases
- The outer casing is built with double thickness in order to preserve heat
- Intense foot reflexology
- For feet up to size 46
- Size: 38.,6 x 24.3 x 45.9 cm

**Funda protectora**  
**Protective bag**u.m.vta: 1  10 **REF. 06109**

- Bolsa 100 unidades funda protectora de polietileno de alta densidad para bañeras de pedicura
- Medidas: 48 cm ancho x 45 cm de largo. Laterales desplegados + 15 cm higiénico
- Evita el contacto de los pies del cliente y la bañera
- Polietileno transparente
- Un solo uso

- Bag 100 protective polyethylene with high thickness protective cover for pedicure bathtubs
- Measures: 48 cm width x 45 height. Scrollable sides +15 cm sanitary
- Avoid feet from contacting with the bathtub
- Transparent polyethylene
- Disposable





05

## Maquillaje Make-up

Lápices, eyeliners, máscara pestañas, esponjas maquillar y desmaquillar, brochas y pinceles...

Pencils, eyeliners, eyelashes mascara, makeup and remover sponges, brushes, pencils...





## Lápices plástico POLLIÉ

### POLLIÉ plastic pencils

u.m.vta: 1

12



○ Blanco · White  
**REF.03788**

● Negro · Black  
**REF.03787**

● Azul · Blue  
**REF.03790**

● Verde · Green  
**REF.03789**

● Marrón · Brown  
**REF.03792**

● Gris · Grey  
**REF.03791**



12,5 cm

● Marrón claro  
Light brown  
**REF.03795**

● Marrón oscuro  
Dark brown  
**REF.03798**

● Morado oscuro  
Dark lilac  
**REF.03799**

● Rojo · Red  
**REF.03796**

● Rosa · Pink  
**REF.03800**



12,5 cm

● Marrón · Brown  
**REF.03794**





12,5 cm

## Lápiz ojos MADERA POLLÍÉ

### POLLÍÉ WOODEN eye pencil



Testado oftalmológicamente  
Ophthalmologically tested

u.m.vta: 1  10 

Lápiz delineador de ojos Khol para ser usado en la línea ocular interior y exterior. Su textura cremosa es suave para la línea interior sensible y para la zona delicada de los ojos.

*Khol eyeliner pencil to be used on both inner and outer eye line.  
Its creamy texture is gentle to the sensitive inner line and on delicate eye area.*

Negro Khol · Black Khol

**REF.06398**

Lápiz delgado extruido de madera.  
Aplicación en la línea del ojo interior y exterior  
*Slim wooden extruded pencil. Application on the inner and outer eye line*

Negro · Black

**REF.06399**

Su alta concentración de los pigmentos hace que el color sea resistente y duradero en el lagimal  
*High concentration of pigments make the colour resistant and lasting on the waterline*

Marrón · Brown

**REF.06400**

Blanco · White

**REF.06402**

Verde · Green

**REF.06403**

Gris · Grey

**REF.06404**

Azul · Blue

**REF.06405**

Lila · Lilac

**REF.06456**



## Lápiz MADERA labios POLLÍÉ

### POLLÍÉ WOODEN lips pencil



u.m.vta: 1	10	
------------	----	--

Lápiz delgado extruido de madera. Aplicación en el contorno de labios y labios.  
Intenso delineador de labios para definir los labios de un solo golpe. Se aplica de forma agadable y cremosa y es fácil de aplicar con un pincel. Rica textura y color intenso que te permite probar la nueva manera de llevar el delineador de labios en un color mate.

*Slim wooden extruded pencil. Application on the lip contour and lips.  
Intense lip liner to define lips in one stroke. It goes on nice and creamy and is easily blendable with a brush. Rich texture and intense colour allow you to try the new way to wear the lip liner as a matte, all-over colour.*

**REF.06406**

Marrón claro  
*Light brown*

**REF.06407**

Vino  
*Wine*

**REF.06408**

Marrón medio  
*Medium brown*

**REF.06409**

Rojo oscuro  
*Dark Red*

**REF.06410**

Rosa  
*Pink*



13,5 cm

## Lápiz madera cejas POLLIÉ

### POLLIÉ wooden eyebrow pencil



Testado oftalmológicamente  
Ophthalmologically tested

u.m.vta: 1 10

Lápiz delgado extruido de madera. Aplicación sobre las cejas

Lápiz de cejas con textura mezclable seca para definir, colorear y rellenar la ceja de una forma perfecta con trazos de colores suaves. Utilice la tapa del cepillo para peinar la ceja antes de la aplicación e incluso para mezclar el color aplicado. Acabado natural que dura horas.

*Slim wooden extruded pencil. Application on the eyebrows*

*Eye brow pencil with dry blendable texture to define, colour and fill the eyebrow into a perfect shape by hair-like soft coloured strokes. Use the brush cap to comb the brow before application and to even and blend the applied color. Natural looking eyebrows finish that lasts hours.*

**REF.06396**

Marrón oscuro  
Dark brown



**REF.06397**

Marrón claro  
Light brown



**REF.06455**

Negro  
Black

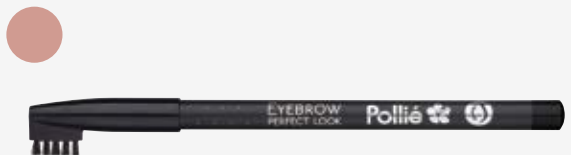

13,5 cm

## Expositor de lápices de ojos, cejas y labios

### Eye liner, eyebrow and lip pencils display

u.m.vta: 1 1

16 colores x 10 unidades  
16 colours x 10 units

Vacío  
Empty

**REF.06807**

**REF.06807/01**

Toda la línea de madera

- 8 colores de ojos
- 5 colores labios
- 3 colores cejas

*The whole line of wood*

- 8 eye colours
- 5 lip colours
- 3 colours eyebrows



### **Eyliner waterproof vegano 4ml** **Vegan waterproof eyeliner 4ml**



u.m.vta: 1  12

**REF.07447**

- Test oftalmológico / Vegano / Waterproof
- Con 12 uds caja expositora gratis
- Ophthalmologically tested / Vegan / Waterproof
- With a 12 pcs free display box



### **Máscara de pestañas** **Eyelashes mask**

u.m.vta: 1  12 

#### **Glamglam volumen e intensidad** **Glamglam volume and intensity**

**REF.06826**

Waterproof  
4D Volumen  
Con ceras naturales

Waterproof  
4D Volume  
With natural waxes

#### **Intensifier negro intenso** **Intensifier intense black**

**REF.06827**

Test dermatológico  
Ceras naturales  
X3 negro

Dermatological test  
Natural waxes  
X3 black

Testado oftalmológicamente  
Ophthalmologically tested



### Esponja desmaquillar celulosa

#### Cellulose make-up remover sponge

u.m.vta: 12  360

REF.01355



REF.01355/77

u.m.vta: 2160  2160

#### Ganel · Bulk





REF.01355/70/01



REF.01355/77/01

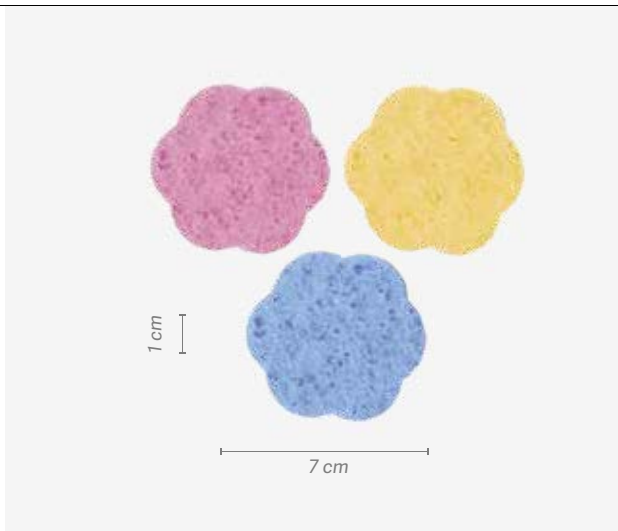

REF.01355/59/01

u.m.vta: 12  240

REF.01938



REF.01938/77

u.m.vta: 1080  1080

#### Ganel · Bulk



REF.01938/70/01



REF.01938/77/01





REF.01938/59/01



### Esponja natural



#### Natural sponge

u.m.vta: 1  16 

REF.02478



Esponja natural baño  
Natural sponge bath

u.m.vta: 1  72 

REF.02453



Para desmaquillar, de textura suave, indicada para pieles sensibles y delicadas. Hipoalergénica  
Make-up remover, soft texture, suitable for sensitive and delicate skin. Hypoallergenic



**Bolsa 2 esponjas planas finas desmaquillar**  
**Bag 2 thin flat make-up remover sponges**

u.m.vta: 12  240

REF.03166



u.m.vta: 12  180

REF.03165

**Húmedas**  
**Damp**





**Bolsa toalla esponja fina desmaquillar**  
**Bag thin make-up remover sponge/towel**

u.m.vta: 12  180

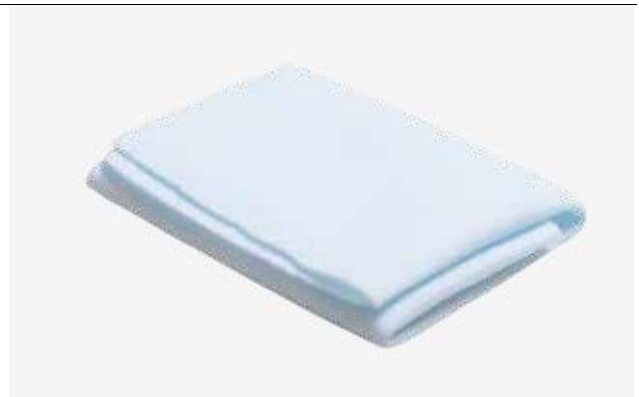
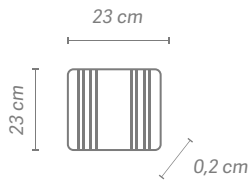
REF.03168



**Esponja no latex - poliuretano**  
**Non-latex sponge - polyurethane**

u.m.vta: 1  15 

REF.07128

REF.07127



Puede usar la esponja mojada o seca. Para uso en seco, es adecuada para aplicar maquillaje en polvo como, polvos compactos, colorete, sombras... Para uso en húmedo, es bueno para aplicar bases, cremas, lociones y otros productos de maquillaje líquidos.

Use wet or dry. For dry use, it is suitable for applying powder make-up such as, pressed powders, blush, shadows... For wet use, it is good for applying bases, creams, lotions and other liquid make-up products.

## Bolsa 2 esponjas cilíndrica maquillaje Bag 2 cylindrical make-up sponges

u.m.vta: 12  180

REF.03167

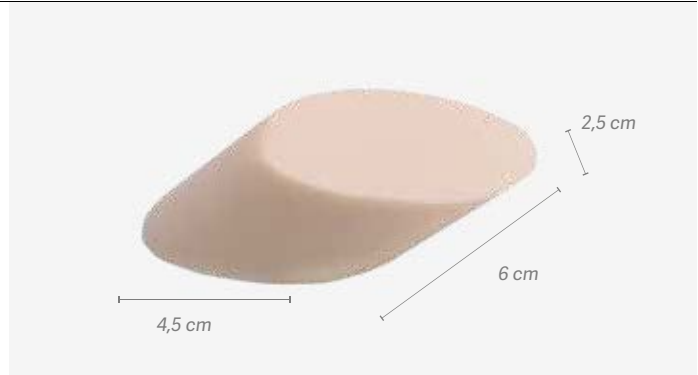

## Esponjas maquillaje Make-up sponges

u.m.vta: 1  300

REF.03559

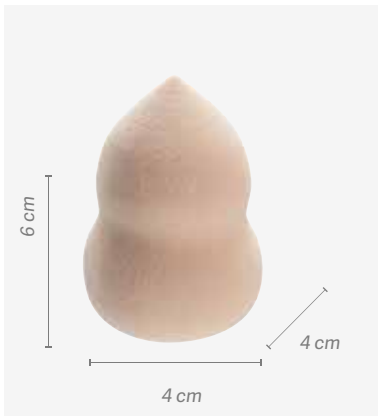

u.m.vta: 12  240

Esponja maquillaje rosa set-4  
Pink make-up sponge set-4

REF.01361

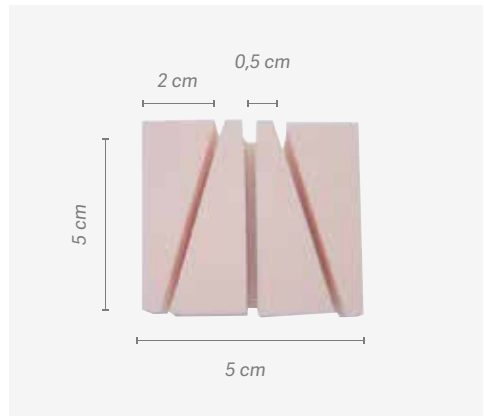

u.m.vta: 12  360

REF.01356

Látex NBR  
NBR latex

u.m.vta: 12  240

REF.02898

Látex NBR  
NBR latex

u.m.vta: 12  240

REF.02897

Látex NBR  
NBR latex

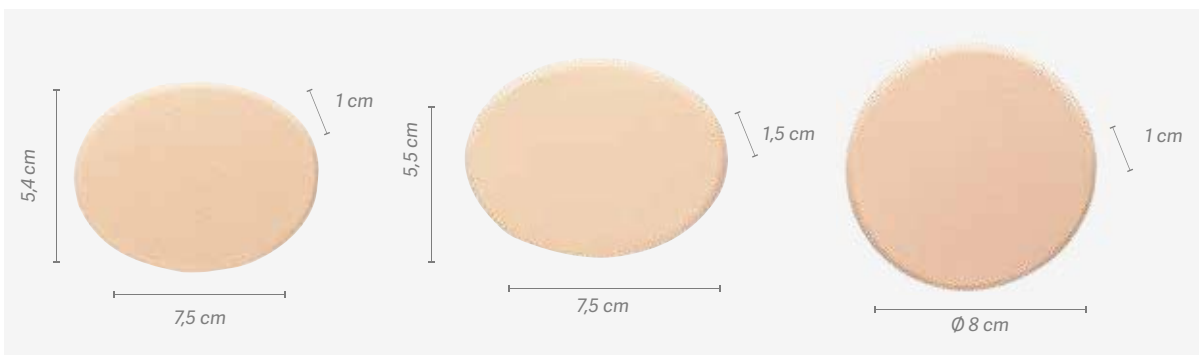

**Esponja maquillaje látex NBR**  
**NBR latex make-up sponge**

u.m.vta: 12  360

**REF.01409**

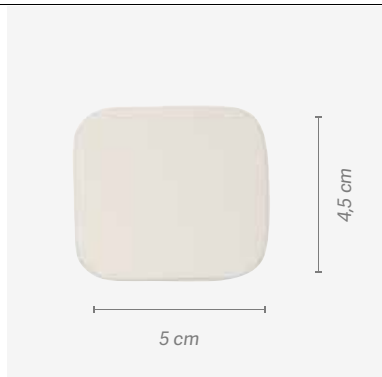

u.m.vta: 12  12

**REF.02899**



**Bolsa 2 esponjas maquillaje látex**  
**Bag 2 latex make-up sponges**

u.m.vta: 12  360

**REF.01410**



u.m.vta: 12  360

**REF.01357**



**Esponja maquillaje**  
**make-up sponge**

u.m.vta: 12  360

**REF.01354**

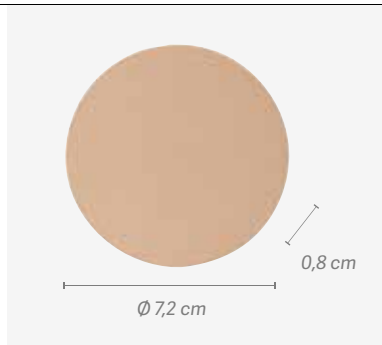

u.m.vta: 12  36

**REF.01358**



u.m.vta: 12  240

**REF.02675**

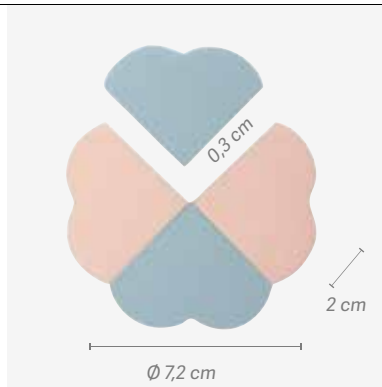

u.m.vta: 12  12

**REF.01459**

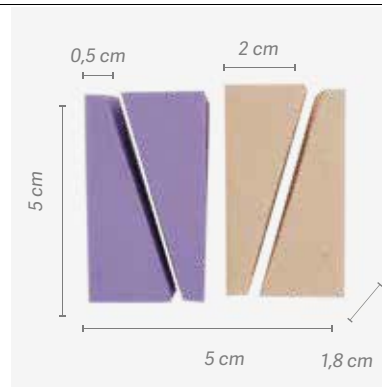



- Bolsa 4 esponjas corazones
- Bag 4 heart colours sponges

- Bolsa 12 esponjas látex SBR
- Bag 12 latex sponges SBR

### Bolsas esponjas maquillaje colores



#### Bags coloured make-up sponges

u.m.vta: 1  252 

8 esponjas  
8 sponges

**REF.01481**





u.m.vta: 1  12 

24 esponjas  
24 sponges

**REF.02671**





u.m.vta: 1  300 

4 esponjas  
4 sponges

**REF.02672**





u.m.vta: 1  12 

Set 3 esponjas + 2 borlas  
Set 3 sponges + 2 tassels

**REF.02673**





u.m.vta: 1  24 

6 esponjas  
6 sponges

**REF.02674**



u.m.vta: 1  120 

33 esponjas  
33 sponges

**REF.02676**



### Borla maquillaje

#### Makeup tassel

u.m.vta: 12  12

**REF.01360**

- Rosa
- Pink

u.m.vta: 12  48

**REF.01411**

- Mediana
- Medium

u.m.vta: 12  36

**REF.01359**

- Grande
- Large



Ø 61 mm





Ø 70 mm



Ø 85 mm

### Brocha colorete ANGLED



#### ANGLED blush brush

u.m.vta: 1		12	
------------	---	----	---

REF.07416

Brocha colorete ANGLED  
ANGLED blush brush





u.m.vta: 1		12	
------------	---	----	---

REF.07408

Brocha para colorete  
Blush brush



u.m.vta: 1		11	
------------	---	----	---



REF.07418

Brocha matizadora  
Blending brush



### Delantal con cinturón para brochas y pinceles

#### Apron with belt for brushes and pencils



u.m.vta: 1		1	
------------	---	---	---

REF.07419



### Cilindro cubilete para brochas y pinceles

#### Beaker cylinder for brushes and pencils



u.m.vta: 1		50	
------------	---	----	---

REF.07420



## Brochas maquillaje POLLIÉ: mango de plástico, pelo sintético

### POLLIÉ make-up brushes: plastic handle, synthetic hair

u.m.vta: 1  6 

- **RESULTADOS PROFESIONALES:** brochas de maquillaje profesionales hechas de cerdas sintéticas de primera calidad para una aplicación precisa, suave y libre de rayas. Mima tu piel con pinceles de maquillaje suaves, fáciles de mantener y libres de crueldad animal
- **MULTIUSOS:** incluye una amplia gama de brochas ovaladas para usar con todos los productos como; contouring, base, corrector de ojeras, polvo...
- **FLEXIBLE:** diseñado para doblarse con el fin de ofrecer una fácil aplicación del maquillaje en zonas de difícil acceso
- **APLICACIÓN SUAVE Y PRECISA:** las cerdas suaves de alta calidad garantizan que los productos como bases, correctores líquidos, cremas BB, coloretes y polvos se puedan aplicar de forma uniforme y suave

- **PROFESSIONAL RESULTS:** professional make-up brushes made of premium quality synthetic bristles for precise, smooth and scratch-free application. Pamper your skin with soft make-up brushes, easy to maintain and free of animal cruelty
- **MULTIPURPOSE:** includes a wide range of oval brushes for use with all products such as; contouring, base, correction of dark circles, powder...
- **FLEXIBLE BRUSHING HANDLE:** the handles of the brushes have been designed to be folded in order to offer easy application of make-up in areas of difficult access
- **SOFT AND PRECISE APPLICATION:** high quality soft bristles ensure that products such as bases, liquid correctors, BB creams, blushes and powders can be applied evenly and smoothly

#### REF.06059

- Redondo grande
- Large round



#### REF.06060

- Redondo mediano
- Medium round



#### REF.06061

- Ovalado grande
- Large oval



#### REF.06062

- Ovalado, pequeño
- Small oval



#### REF.06063

- Redondo mini
- Mini round



#### REF.06064

- Set 5 cepillos
- 5 brushes set







**Pincel sombra de ojos**  
**Eyeshadow brush**

u.m.vta: 1 25

Nº7

REF.07393



Nº6

REF.07394



Nº5

REF.07395



Nº4

REF.07396



Nº3

REF.07397



Nº2

REF.07398



Nº1

REF.07399

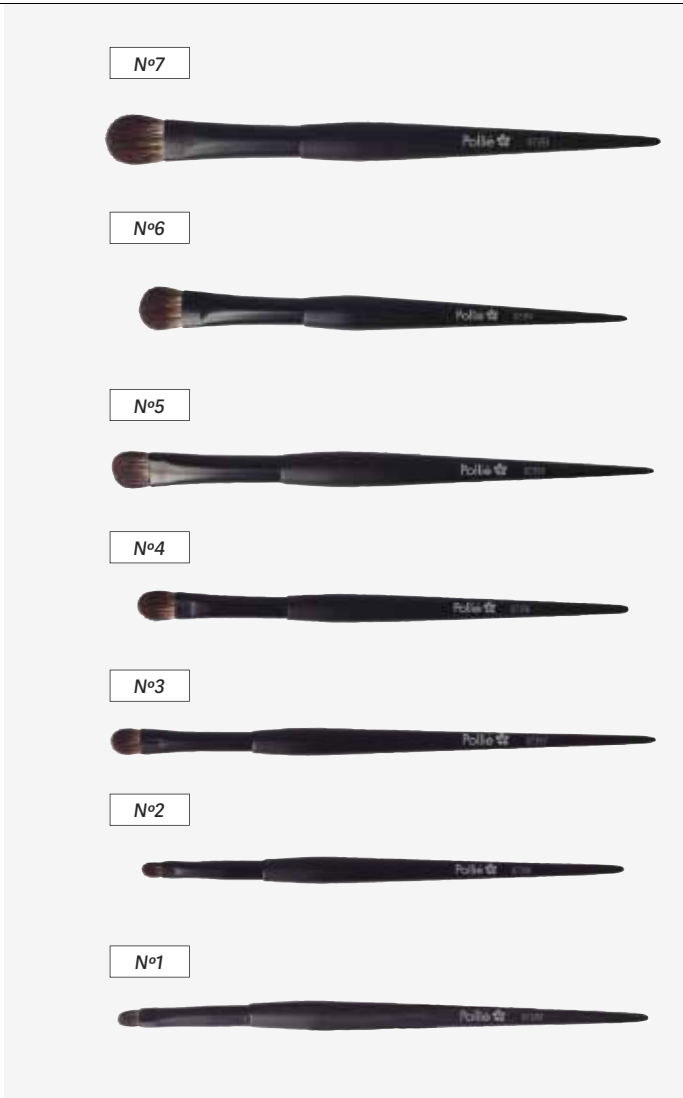

**Pincel para eyeliner**  
**Eyeliner brush**

u.m.vta: 1 25

REF.07400





**Pincel difuminador delineador de ojos**  
**Eyeliner Blending Brush**

u.m.vta: 1 25

REF.07401



### Pincel corrector/difuminador Healing / Blurring Brush

u.m.vta: 1  25 

REF.07402

Nº5



REF.07403

Nº4



REF.07404

Nº3



REF.07405

Nº2





REF.07406

Nº1





### Pincel contouring sombras nariz Contouring brush nose shadows

u.m.vta: 1  25 

REF.07407



### Pincel corrector Makeup concealer brush

u.m.vta: 1  25 

REF.07409





### Pincel labios retráctil Retractable lip brush

u.m.vta: 1  25 

REF.07410





**Pincel difuminador de cejas**  
**Brow Blending Brush**

u.m.vta: 1  25 

REF.07411





**Pincel peine para cejas**  
**Eyebrow Comb Brush**

u.m.vta: 1  25 

REF.07417



**Brocha FOUNDATION**  
**FOUNDATION brush**

u.m.vta: 1  12 

Nº4

REF.07412



Nº3

REF.07413



Nº2

REF.07414



Nº1

REF.07415





## PINCELES KABUKI KABUKI BRUSHES

Los pinceles Kabuki son considerados los mejores para la aplicación del maquillaje, las sombras de ojos o el colorete. Aportan una sensación de suavidad extrema como una caricia en la piel del cliente y permiten un acabado de cine. Son indispensables para un profesional del maquillaje.

*Kabuki brushes are deemed to be the best when it comes to applying make-up, eye shadow and rouge. They are extremely soft to the touch when used, feeling like a gentle caress on the client's skin, and they provide you with a professional, movie-like finish. They are an absolute must for make-up professionals.*

### Pinceles profesionales KABUKI KABUKI professional brushes

Sintético  
Synthetic

u.m.vta: 1  12 

Cónico  
Conical

**REF.04094**



Ángulo  
Angular

**REF.04095**



Redondo  
Round

**REF.04096**



Plano  
Flat

**REF.04097**



Cónico medio  
Conical medium

**REF.04111**



Sombra cónico  
Conical shadow

**REF.04098**



Sombra ángulo  
Angular shadow

**REF.04099**



Sombra plano  
Flat shadow

**REF.04101**



**Pinceles KABUKI**  
**KABUKI cosmetic brushes**

Sintético  
 Synthetic

u.m.vta: 1	 12	
------------	--	---

**REF.04703** Redondo  
 Round





**REF.04704** Oblicuo  
 Oblique



**REF.04705** Despuntado  
 Blunt



Sintético  
 Synthetic

u.m.vta: 1	 12	
------------	--	---

Redondo, sombra  
 Round, shade

**REF.04100**



Esponja látex  
 Latex sponge

**REF.04102**



Cónico pequeño  
 Small conical

**REF.04112**



Redondo  
 Round

**REF.04113**



Estrecho  
 Narrow

**REF.04114**





Plano recto  
 Flat straight

**REF.04115**



## Brocha maquillaje Make-up brush

u.m.vta: 1  12 

Brocha para polvos  
Powder brush

REF.07390



Brocha para contouring/coloret  
Powder brush

REF.07391



Brocha para iluminador  
Highlighter brush

REF.07392



## Brocha KABUKI KABUKI brush

u.m.vta: 1  12

REF.03561

- Brocha maquillaje pelo sintético/Taklon
- Diámetro pelo: 27,5 mm
- Packaging: bolsa individual de plástico
- Ideal para llevar sin ocupar espacio
- Synthetic /Taklon make-up brush
- Hair diameter: 27.5 mm
- Packaging: Individual plastic bag
- Ideal for carrying without taking up space



## Cepillo cosmético y brochas de maquillaje KABUKI PELO NATURAL KABUKI,NATURAL HAIR Cosmetic and make-up brushes

u.m.vta: 12  72

REF.01812

- Cepillo cosmético  
bolso, mango  
plástico
- Pelo de cabra
- Cosmetic brush  
handbag, plastic  
handle
- Goar hair

u.m.vta: 1  120

REF.03560

- Brocha maquillaje pelo natural
- Diámetro pelo: 27,5 mm
- Packaging: Bolsa individual de plástico
- Ideal para llevar sin ocupar espacio
- Natural hair make-up brush
- Hair diameter: 27.5 mm
- Packaging: Individual plastic bag
- Ideal for carrying without taking up space





## Pinceles mango madera

### Wooden handle brushes

u.m.vta: 1



12

**REF.02884**

Matizador. Pelo de cabra  
Powder brush. Goat fur

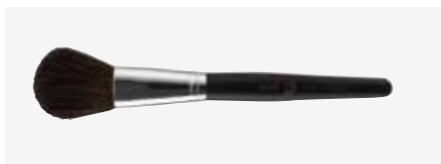
**REF.02885**

Colorete. Pelo de cabra  
Red powder brush. Goat fur

**REF.02886**

Difuminador. Pelo de ardilla  
Face mask brush. Squirrel fur

**REF.02887**

Pincel sombra Pelo de ardilla  
Eye shadow brush. Squirrel fur

**REF.02888**

Pincel ojos. Pelo de marta  
Eye shadow brush. Sable fur

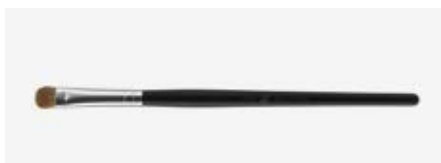
**REF.02889**

Pincel sombra. Pelo de marta  
Eye shadow brush. Sable fur

**REF.02890**

Pincel labios. Pelo de marta  
Lip brush. Sable fur

**REF.02891**

Pincel labios. Pelo de marta  
Lip brush. Sable fur

**REF.02892**

Pincel sombra. Pelo de marta  
Eye shadow brush. Sable fur

**REF.02893**

Pincel esponja látex  
Latex sponge brush

**REF.02894**

- Pincel máscara
- Nylon
- Mask brush
- Nylon

**REF.02895**

- Peine profesional máscara
- Pincel jabalí
- Eyelash mask brush & comb professional
- Boar fur



## Pinceles mango madera

### Wooden handle brushes

u.m.vta: 1

12

**REF.01814**

- Cepillo cosmético matizador
- Pelo de cabra
- Powder brush
- Goat fur

**REF.01815**

- Cepillo cosmético colorete
- Pelo de cabra
- Red powder brush
- Goat fur

**REF.01816**

- Cepillo cosmético esponja
- Sponge brush

**REF.01817**

- Cepillo cosmético ojos
- Pelo de marta
- Eye brush
- Sable fur

**REF.01818**

- Cepillo cosmético sombra
- Pelo de cabra + pony
- Eye shadow brush
- Goat + pony fur

**REF.01819**

- Cepillo cosmético labios
- Pelo de cabra + pony
- Lip brush
- Goat + pony fur

**REF.01821**

- Cepillo cosmético sombra
- Pelo de cabra + pony
- Eye shadow brush
- Goat + pony fur

**REF.01820**

- Cepillo pincel/peine máscara
- Pelo de jabalí
- Eyelash mascare brush & comb
- Boar fur



## Ideal maquillaje fluido

### Ideal fluid make-up

Sintético  
Synthetic**REF.04511**

- Mango plástico
- Plastic handle



**REF.04512**

- Mango madera
- Wooden handle



## Pinceles mango madera

### Wooden handle brushes

u.m.vta: 1  12 

#### REF.01800

- Pincel matizador
- Pelo de cabra
- Powder brush
- Goat fur

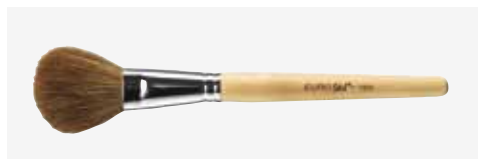

#### REF.01801

- Pincel colorete
- Pelo de cabra
- Red powder brush
- Goat fur



#### REF.01802

- Pincel mascarilla
- Pelo de cerda
- Face mask brush
- Pig fur



#### REF.01803

- Pincel abanico
- Pelo de cabra
- Fan brush
- Goat fur



#### REF.01804

- Pincel ojos
- Pelo de marta
- Eye shadow brush
- Sable fur



#### REF.01805

- Pincel labios
- Pelo sintético
- Lip brush
- Synthetic fur



#### REF.01806

- Pincel sombra
- Pelo de sintético
- Shadow brush
- Synthetic hair fur



#### REF.01807

- Pincel sombra
- Pelo de cabra + pony
- Shadow brush
- Goat + pony fur



#### REF.01808

- Pincel esponja latex
- Latex sponge brush



#### REF.01809

- Pincel máscara
- Nylon
- Mask brush
- Nylon



#### REF.01810

- Pincel-peine máscara
- Pelo de jabalí
- Mask brush - comb
- Boar fur



**Expositor 66 pinceles cosmética**  
**66 cosmetic brushes display**

u.m.vta: 1  2

**REF.01466**



(6 ud. x ref. ) Para más información sobre los pinceles consultar página 757  
 For more information about make-up brushes page 757

**Pinceles**  
**Brushes**

u.m.vta: 12  12

**REF.01508**

- Doble esponja
- Double sponge



u.m.vta: 12  12

**REF.01509**

- Pincel / esponja
- Brushes / sponge





**Sacapuntas**  
**Pencil sharpener**

u.m.vta: 12  60

**REF.01067**

- Normal / gueso
- Normal / thick



u.m.vta: 12  72 

**REF.06364**

- Sacapuntas doble cosmética
- Double pencil sharpener



**Bolsa aplicadores sombra**  
**Bag eyeshadow brushes**

u.m.vta: 12  120

5 u

**REF.01505**

- Colores
- Colours



u.m.vta: 12  240

5 u

**REF.01507**



u.m.vta: 12  120

12 u

**REF.01506**

- Colores
- Colours



**Limpiador de silicona de pinceles de maquillaje**  
**Silicone cleaner of make-up brushes**

u.m.vta: 1  12

REF.04706



**Estuche redondo 7 pinceles maquillaje con espejo**  
**Round case with 7 make-up brushes mirror**

u.m.vta: 1  6 



REF.03562





### Set 12 pinceles cosmética

#### Set 12 cosmetic brushes

u.m.vta: 1	 6	
------------	---	---

REF. 02896

- Contiene: 02884, 02885, 02886, 02887, 02888, 02889, 02890, 02891, 02892, 02893, 02894, 02895
- Contains: 02884, 02885, 02886, 02887, 02888, 02889, 02890, 02891, 02892, 02893, 02894, 02895



Para más información sobre los pinceles consultar página 755

For more information about make-up brushes page 755



### Estuche 7 pinceles maquillaje pelo sintético

#### Case 7 synthetic hair make-up brushes

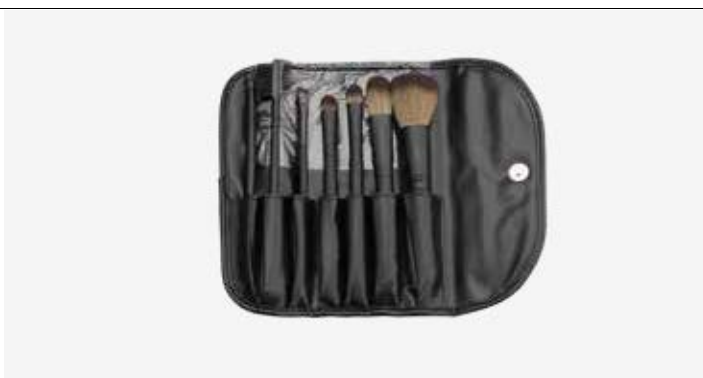

u.m.vta: 1	 6	
------------	---	---

REF.03563



### Estuche pinceles cosmética (vacío)

#### Case with make-up brushes (empty)

u.m.vta: 1	 120	
------------	---	---

REF.03564



### Set 5 pinceles

#### Set 5 cosmetic brushes

u.m.vta: 12	 120
-------------	---

REF.02585

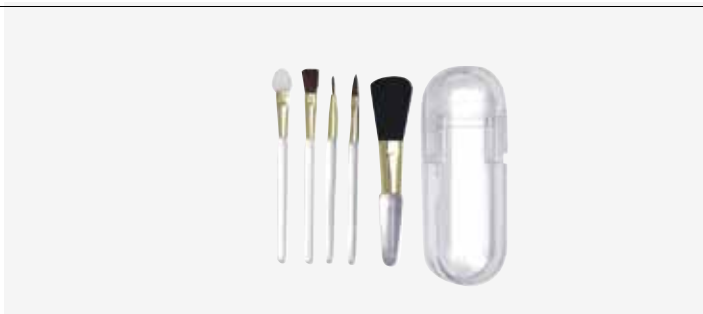

06

## Pestañas Eyelashes

*Pestañas completas, pestañas individuales,  
pestañas adhesivas, cejas...*

*Full eyelashes, individual eyelashes,  
adhesive eyelashes, eyebrows...*



## Pestañas POLLÍE individuales negras POLLÍE individual black eyelashes

u.m.vta: 1  50

### Pestañas individuales en 4 pasos:

1. Limpie sus pestañas naturales y los párpados para que estén libres de maquillaje e impurezas
2. Extraiga las pestañas de la caja con las pinzas Pollié (ref 06562)
3. Aplique una gota de adhesivo en el papel metálico y empape la base de la pestaña con el adhesivo
4. Coloque la extensión sobre la pestaña natural cerca de la línea de las pestañas SIN TOCAR el párpado  
Aplique tantas pestañas como se desee para conseguir el resultado deseado

### ¿Cómo quitar tus pestañas Pollié?

Impregnar dos algodones con el quita pestañas Pollié. Colocar un algodón debajo de las pestañas y otro por encima. Frotarlos suavemente hasta que se despeguen las pestañas.

### A set of individual lashes in 4 steps:

1. Clean your natural lashes and eyelids so they are free of makeup and impurities
2. Take the lashes out of the box using the Pollié tweezers (ref 06562)
3. Apply a drop of adhesive to a piece of tin foil and soak the base of the lash in the adhesive
4. Place the lash on the natural lash near the lash line WITHOUT TOUCHING the eyelid. Apply as many lashes as desired to achieve the desired result

### How to remove your Pollié lashes?

Soak two cotton pads with the Pollié eyelash remover. Place one cotton pad under the lashes and one on top. Rub gently until the lashes come off

**REF.06508**

- Cortas
- Negras

- Short
- Black

**REF.06509**

- Medias
- Negras

- Medium
- Black

**REF.06510**

- Largas
- Negras

- Long
- Black

**REF.06511**

- Mixtas
- Negras

- Mixed
- Black

**REF.06512**

- Cortas
- Dúo

- Short
- Duo

**REF.06513**

- Medias
- Dúo

- Medium
- Duo

**REF.06514**

- Largas
- Dúo

- Long
- Duo

**REF.06515**

- Cortas
- Trio

- Short
- Trio

**REF.06516**

- Media
- Trio

- Medium
- Trio

**REF.06519**

- Largas
- Trio

- Long
- Trio







**Pestañas POLLIÉ negras 100% natural**  
**100% natural black POLLIÉ eyelashes**

u.m.vta: 1 50



**Pestañas completas en 4 pasos:**

1. Adaptar las pestañas a la medida correcta: alinear las pestañas con su línea natural de pestañas y recortar en caso de exceso
2. Aplicación del adhesivo: aplicar una línea fina de adhesivo a lo largo de la banda y esperar 20-30 segundos. En caso de exceso de adhesivo, utilice desmaquillante para eliminar la parte sobrante
3. Aplicación de las pestañas: colóquelas con adhesivo por encima de la línea natural de las pestañas, presionando ligeramente hasta fijarlas
4. Retoque final: utilizar las pinzas Pollié (ref 06314) para ajustar las pestañas de forma que queden bien alineadas y fijas

**¿Cómo quitar tus pestañas Pollié?**

Desenganchar la tira de pestañas empezando por el extremo exterior. Coloque las pestañas en su caja para utilizarlas en un futuro

*A complete set of lashes in 4 steps:*

1. Adapt the lashes to the correct size: align the lashes with your natural lash line and trim if they are too long
2. Application of the adhesive: apply a thin line of adhesive along the strip and wait 20-30 seconds. If you have too much adhesive, use make-up remover to remove the excess
3. Application of the lashes: place the lashes with adhesive over the natural lash line, pressing lightly until the adhesive has set
4. Final touch: use the Pollié tweezers (ref 06314) to adjust the lashes so that they are properly aligned with yours and have set properly

*How to remove your Pollié lashes?*

*Gently pull the lash strip starting at the outer end. Place the lashes in their box for future use*

REF.06487



Nº1

REF.06488



Nº2

REF.06489



Nº3

REF.06490



Nº4

REF.06491



Nº5

REF.06492



Nº6

REF.06493



Nº7

REF.06494



Nº8

REF.06495



Nº9

REF.06496



Nº10

## Pestañas POLLÍE negras 100% natural 100% natural black POLLÍE eyelashes

Pollie 

u.m.vta: 1  50



### Pestañas completas en 4 pasos

1. Adaptar las pestañas a la medida correcta: alinear las pestañas con su línea natural de pestañas y recortar en caso de exceso
2. Aplicación del adhesivo: aplicar una línea fina de adhesivo a lo largo de la banda y esperar 20-30 segundos. En caso de exceso de adhesivo, utilice desmaquillante para eliminar la parte sobrante
3. Aplicación de las pestañas: colóquelas con adhesivo por encima de la línea natural de las pestañas, presionando ligeramente hasta fijarlas
4. Retoque final: utilizar las pinzas Pollié (ref 06314) para ajustar las pestañas de forma que queden bien alineadas y fijas

### ¿Cómo quitar tus pestañas Pollié?

Desenganchar la tira de pestañas empezando por el extremo exterior. Coloque las pestañas en su caja para utilizarlas en un futuro

### A complete set of lashes in 4 steps:

1. Adapt the lashes to the correct size: align the lashes with your natural lash line and trim if they are too long.
2. Application of the adhesive: apply a thin line of adhesive along the strip and wait 20-30 seconds. If you have too much adhesive, use make-up remover to remove the excess
3. Application of the lashes: place the lashes with adhesive over the natural lash line, pressing lightly until the adhesive has set
4. Final touch: use the Pollié tweezers (ref 06314) to adjust the lashes so that they are properly aligned with yours and have set properly

### How to remove your Pollié lashes?

Gently pull the lash strip starting at the outer end. Place the lashes in their box for future use

REF.06497



Nº11

REF.06498



Nº12

REF.06499



Nº13

REF.06500



Nº14

REF.06502



Nº15

REF.06503



Nº16

REF.06504



Nº17

REF.06505



Nº18

REF.06506



Nº19

REF.06507



Nº20

**Set 3 pinzas individuales pelo a pelo**  
**Set 3 individual tweezers one by one hair**

**Pollié** 

u.m.vta: 1  12

**REF.06562**

Set de 3 pinzas para la colocación de pestañas postizas y extensiones de pestañas. Con un cómodo estuche de metal

Set of 3 tweezers for the placement of false eyelashes and eyelash extensions. With a comfortable metal case







### ¿QUÉ FORMA DE OJOS TIENES?

Determinar la forma de los ojos es el primer paso para decidir qué estilo de pestañas es adecuado para ti.

#### OJOS REDONDOS

Pestañas clásicas, mezcla de cortas y largas suavizan la mirada:

ref. 02700, 02693, 02695, 04079

#### OJOS ALMENDRADOS

Pestañas densas y más finas hacia las puntas:

ref. 02690, 02691, 02698, 02699, 02701

#### OJOS HUNDIDOS O PEQUEÑOS

Pestañas poco pobladas y largas para abrir la mirada:

ref. 02696, 02697, 02692, 02694

### WHAT IS YOUR EYE SHAPE?

Determining the shape of your eyes is the first step to decide which style of eyelashes is most suitable for you.

#### ROUND EYES

Classic eyelashes, a blend of short and long eyelashes provide you with a softer look: Ref. 02700, 02693, 02695, 04079

#### ALMOND EYES

Thick eyelashes that are thinner towards the ends: Ref. 02690, 02691, 02698, 02699, 02701

#### SUNKEN OR SMALL EYES

Scarce and long eyelashes to open up your gaze: Ref. 02696, 02697, 02692, 02694

### ¿Cómo usar?

#### How to use?



#### **Pestaña completa**

##### **Full eyelashes**

1. Tomar la medida con tu ojo y cortar el sobrante
2. Aplique una línea delgada de adhesivo a lo largo de la banda. Esperar 30 segundos para ajustar
3. Con ayuda de unas pinzas colocar sobre el párpado en el nacimiento de las pestañas
4. Maquillar y ¡listo!

1. Measure the width of your eye and cut off the excess length
2. Apply a thin line of adhesive throughout the length of the band. Wait 30 seconds before applying the eyelashes
3. Using a pair of tongs, place them on the eyelid, at the birth of your natural eyelashes
4. Apply make-up and hey, presto!





#### **Pestaña individual** **Individual eyelashes**

1. Coger pestaña con unas pinzas
2. Mojar la base en adhesivo
3. Colocar en el nacimiento de las pestañas. Nunca en el párpado
4. Maquillar y ¡listo!

1. Gasp the eyelash with the tongs
2. Dip the base in the adhesive
3. Place it on the root of the eyelashes. Never on the eyelid
4. Apply make-up and hey, presto!

**Para un look natural y sofisticado**  
**For a natural and sophisticated look**



u.m.vta: 1  12 

**REF.06314**



**Ayuda a colocar pestañas postizas**  
*Help to place false eyelashes*

**Pestañas ANDREA SM**  
**ANDREA SM eyelashes**

u.m.vta: 4  72

62 negras  
62 black

●  
**REF.02700**



21 negras  
21 black

●  
**REF.02690**



23 negras  
23 black

●  
**REF.02692**



28 negras  
28 black

●  
**REF.02694**



45 negras  
45 black

●  
**REF.02696**



53 negras  
53 black

●  
**REF.02698**



70 negras  
70 black

●  
**REF.02701**



21 marrón  
21 brown

●  
**REF.02691**



26 negras  
26 black

●  
**REF.02693**



33 negras  
33 black

●  
**REF.02695**



45 marrón  
45 brown

●  
**REF.02697**



53 marrón  
53 brown

●  
**REF.02699**



**Pestañas completas auto adhesivas negras**  
**Full black auto adhesive eyelashes**

u.m.vta: 4 72

33 negras  
 33 black  
**REF.03670**



21 negras  
 21 black  
**REF.03672**



45 negras  
 45 black  
**REF.03673**



53 negras  
 53 black  
**REF.03671**



**Pestañas completas**  
**Full eyelashes**

u.m.vta: 4 72

52 negras  
 52 black  
  
**REF.04841**



33 marrón  
 33 brown  
  
**REF.04079**



80 negras  
 80 black  
  
**REF.04842**



45 negras  
 45 black  
  
**REF.04843**



19 negras  
 19 black  
  
**REF.04844**



Mod. Accents  
 318 negras  
 318 black  
 Accents mod.  
  
**REF.04846**



Mod. Accents.  
 301 negras  
 301 black  
 Accents mod.  
  
**REF.04554**



Mod. Accents  
 305 negras  
 305 black  
 Accents mod.  
  
**REF.04555**





**Pestañas completas Lashlites**  
*Self-adhesive full false eyelashes in black color*

u.m.vta: 4 72

**REF.04845** Lashlites 335. Negras  
 Lashlites 335, Black



**Kit pestañas Andrea Starter**  
*Andrea Starter eyelash kit*

u.m.vta: 4 36

Starter 45  
 Starter 45

**REF.02704**



Starter 53  
 Starter 53

**REF.02703**



Starter 33  
 Starter 33

**REF.02702**



**Mechón pestañas sin nudos**  
*Stacked Individual knot free*

u.m.vta: 4 72

Largas  
 Long



**REF.04553**



Medianas  
 Medium



**REF.04552**



Cortas  
 Short



**REF.04551**



**Antes . Before**

**Después . After**



**Pestañas Permalash individuales, mechones**  
**Permalash individual eyelashes, locks**

u.m.vta: 4  72

Medianas, marrón SM  
SM brown. Medium



REF.02708



Combo. Negras  
Combo. Black



REF.03278



Medianas. Negras SM  
SM black. Medium



REF.02707



Largas. Negras  
Long. Black



REF.04078



Pequeñas. Negras SM  
SM black. Small



REF.02705



Pequeñas, Marrón SM  
SM brown  
Small



REF.02706



Mediana pelo a pelo negras  
Medium hair one by  
one black



REF.03277



Corta pelo a pelo negras  
Hair one by one black



REF.03276



**Kit pestañas individuales combo negras**  
**kit individual combo black eyelashes**

u.m.vta: 4  36

REF.04077





### Adhesivo pestañas individuales

#### Adhesive individual eyelashes

No apto para pestañas completas  
Not suitable for full lashes

u.m.vta: 6  72

Andrea Permalash **claro** transparente  
Andrea Permalash **clear** transparent

**REF.02713**

3,5 g



Andrea Permalash **oscuro**  
Andrea Permalash **dark**

**REF.03066**

3,5 g



### Disolvente adhesivo pestañas INDIVIDUALES

#### INDIVIDUAL eyelashes adhesive remover

No apto para pestañas completas  
Not suitable for full lashes

u.m.vta: 6  72

**REF.03204**

3,5 g



### Adhesivo pestañas COMPLETAS

#### Adhesive FULL lashes

No apto para pestañas individuales  
Not suitable for individual lashes

u.m.vta: 6  72

Andrea Modlash **claro**: transparente  
Andrea Modlash **clear**: transparent

**REF.02711**

3,5 g



Andrea Modlash **oscuro**  
Andrea Modlash **dark**

**REF.02712**

3,5 g



### Expositor pestañas Andrea Andrea eyelashes display

u.m.vta: 1  1

REF.03203



Expositor giratorio  
Rotary display



Contiene 8 unidades de cada una:

- Pestañas completas: 02690, 02691, 02693, 02695, 02696, 02698, 02700, 02701.
- Adhesivo pestañas completas: 02711 (claro), 02712 (oscuro)
- Pestañas individuales: 02705, 02706, 2707, 02708, 03278
- Adhesivo pestañas individuales:
- 02713 (claro), 03066 (oscuro)
- Disolvente adhesivo pestañas individuales: 03204



It contains 8 units of each:

- Full eyelashes: 02690, 02691, 02693, 02695, 02696, 02698, 02700, 02701.
- Adhesive full eyelashes: 02711 (clear), 02712 (dark)
- Individual eyelashes: 02705, 02706, 2707, 02708, 03278
- Adhesive individual eyelashes: 02713 (light), 03066 (dark)
- Solvent adhesive individual eyelashes: 03204

### Riza pestañas Curler eyelashes

u.m.vta: 12  120

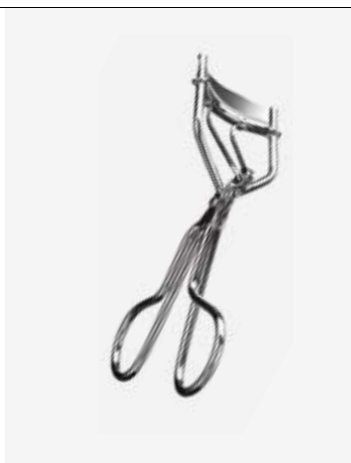
REF.01109

u.m.vta: 1  1

REF.03335



Expositor giratorio  
Rotary display

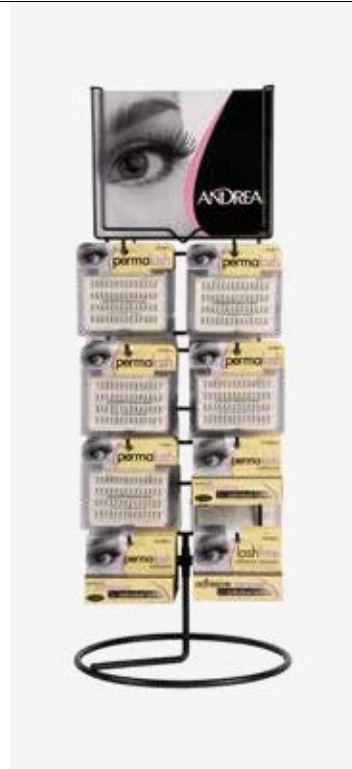

Expositor pestañas Andrea VACÍO  
Andrea eyelashes display EMPTY

### Recambio goma riza pestañas Spare rubber curl eyelashes



u.m.vta: 12  12

2 u

REF.01110



**3 Navajas pollié para ceja**  
**3 Pollie eyebrow razors**

u.m.vta: 1		12	
------------	---	----	---

Cuchilla para cejas, vello facial y vello corporal. Se aconseja aplicar gel o crema en la zona que se desea afeitar, para que sea un corte más suave y cómodo. El mango está fabricado en ABS mientras que la hoja está fabricada en acero inoxidable de alta calidad.

*Eyebrow blade, facial hair and body hair. For best results and a softer and more comfortable cut, apply gel or cream to the area you wish to shave. The handle is made of ABS while the blade is made of high-quality stainless-steel.*

**REF.07125**



**REF.07126**



**Cejas Andrea**  
**Andrea eyebrows**

u.m.vta: 1		24
------------	---	----

3 en 1 crema marrón medio  
 3 in 1 medium brown cream

**REF.06286**



Powder duo marrón medio  
 Powder duo medium brown

**REF.06287**



Powder duo marrón oscuro  
 Powder duo dark brown

**REF.06288**



Pencil duo marrón oscuro  
 Pencil duo dark brown

**REF.06289**



07

## Accesorios e higiene Accessories and hygiene

Fundas y papel de camillas, toallas, sábanas,  
espejos, vestuario, maletas...



Covers and massage table paper, towels,  
bed sheets, mirrors, clothing, suitcases...





### Bolsa 10 Fundas ajustable camilla

#### Bag 10 adjustable massage table covers

u.m.vta: 1  10 

30 g

**REF.07308**

- Material: Non woven
- Dimensiones: 210 cm x 80 cm
- Caja 100 unidades funda camilla ajustable por los extremos
- Presentado en bolsa individual
- Peso: 30 g

- Material: Non - woven
- Measures: 210 cm x 80 cm
- Box 100 u massage table covers with adjustable rubber
- Presented in an individual bag
- Paper weight: 30 g



### Rollo papel camilla

#### Massage table paper roll

u.m.vta: 6  6 



**REF. 00928**

- Largo: 78 m / ancho: 59 cm
- Gamaje del papel: 43 g
- 40 servicios marcados y precortados, de 1,95 m de largo cada uno
- Los rollos van embolsados individualmente

- Length: 78 m / width: 59 cm
- Paper weight: 43 g
- 40 marked and pre-cut service lengths, each one of which is 1,95 m long
- The rolls are bagged individually



**REF.00928/75**

43 g



### Rollo papel camilla súper ancho

#### Extra wide massage table paper roll

u.m.vta: 6  6 

**REF. 03336**

- Súper ancho: 78 cm
- 40 servicios marcados y precortados de 1,95 m de largo cada uno
- Los rollos van embolsados individualmente

- Extra wide: 78 cm
- 40 marked and pre-cut service lengths each one of which is 1.95 m long
- The rolls are bagged individually

43 g



### Manta eléctrica para camillas

#### Electric blanket for massage table

u.m.vta: 1  4

90 g

REF. 07791



Sistema de seguridad con protección sobre el calentamiento. 3 niveles de temperatura. Lavable gracias al termostato desmontable. Material superior agradablemente suave. Apagado automático después de 180 minutos. Controlador práctico. Adecuado para colchones de tamaño 200x90-100cm. Estándar 100 oeko-tex.

Datos técnicos:

- Tamaño 150x80cm
- peso aproximado 1kg
- Fuente de alimentación 230v~ 50hz
- potencia de salida 60w

Safety system with protection over heating. 3 temperature levels. Washable thanks to the removable thermostat. Pleasantly soft upper material. Auto power off after 180 minutes. Practical controller. Suitable for mattresses of size 200x90-100cm. Standard 100 oeko-tex

Technical data:

- Size 150x80cm
- Approximate weight 1kg
- Power supply 230v~ 50hz
- Output power 60w

### 30 sábanas sudoración

#### 30 sweats bed sheets

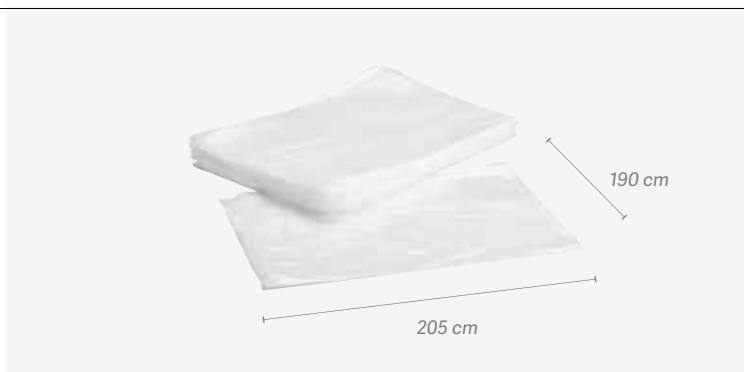

u.m.vta: 1  10

REF. 03912



### Funda camilla tergal blanca

#### White tergal massage table cover



u.m.vta: 1  12 

REF. 06650





**Bolsa de 75 Toallas CELULOSA**  
**Bag with 75 CELLULOSE towels**



u.m.vta: 1		16	
------------	---	----	---

Especial manicura  
 Special manicure

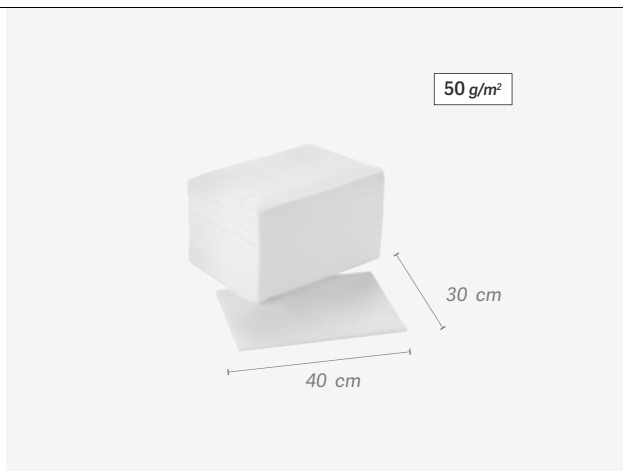
**REF. 04204**





**Bolsa de 90 toallas CELULOSA**  
**Bag with 90 CELLULOSE towels**

u.m.vta: 4		144	
------------	---	-----	---

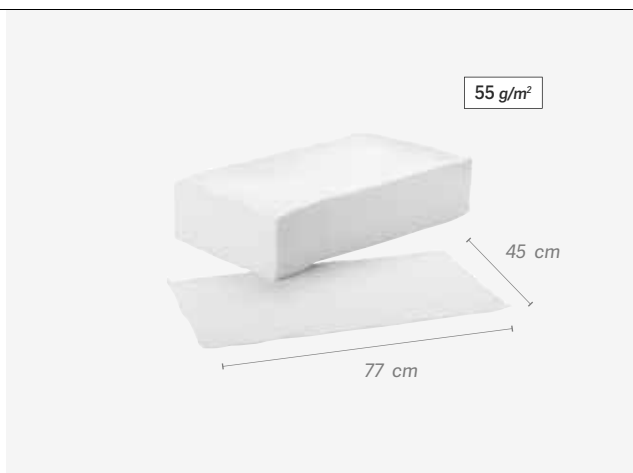
**REF.04076**



**35 toallas SPUNLACE**  
**35 SPUNLACE towels**

u.m.vta: 1		12	
------------	---	----	---



50 g/m<sup>2</sup>

**REF. 04509**

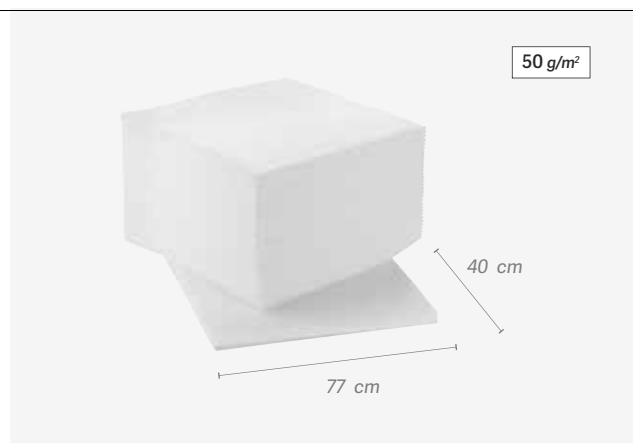

- Súper absorbentes
- Toallas dobladas

- Super absorbent
- Bent towels



**Bolsa de 25 toallas SPUNLACE****Bag 25 SPUNLACE towels**u.m.vta: 1  24 50 g/m<sup>2</sup>

40 x 90 cm



**REF. 04916**u.m.vta: 1  28 50 g/m<sup>2</sup>

40 x 80 cm

**REF. 03221**



- Dobladas a 20 x 20 cm
- 50% poliéster / 50% viscosa

- Bent to 20 x 20 cm
- 50% polyester / 50% viscose



**Bolsa 100 toallas SPUNLACE****Bag 100 SPUNLACE towels**u.m.vta: 1  16 50 g/m<sup>2</sup>**REF. 07302**

- Composición: 50% viscosa / 50% poliéster.
- Producto de gran resistencia y absorción, versátil, práctico y desechable
- Totalmente libre de látex, de tacto muy suave

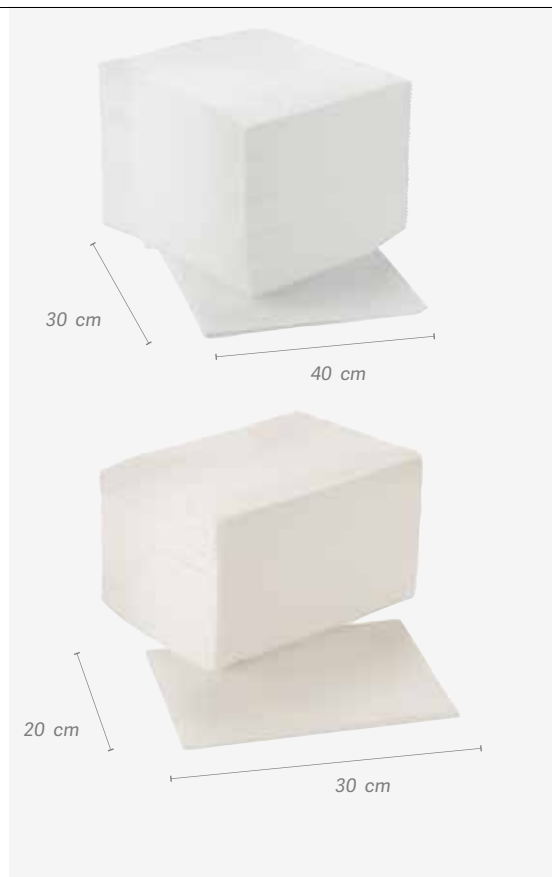
- Composition: 50% viscose / 50% polyester
- Highly resistant and absorbent, versatile, practical and disposable.
- Totally latex-free, extra soft feel

u.m.vta: 1  32 50 g/m<sup>2</sup>**REF. 07303**

**Bolsa 75 toallas SPUNLACE**  
**Bag 75 SPUNLANCE towels**

u.m.vta: 1		16	
------------	---	----	---



**REF. 04510**

- Súper absorbentes
- Toallas dobladas
- Especial manicura

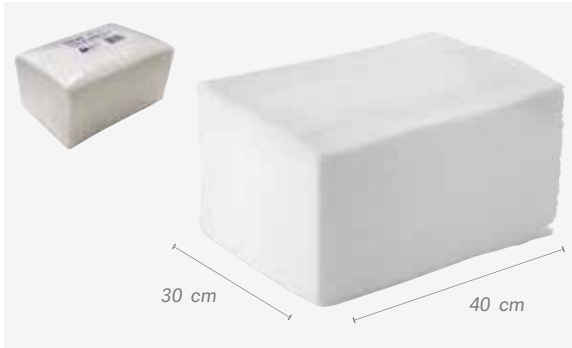
- Super absorbent
- Bent towels
- Special manicure



**Bolsa de 100 toallas SPUNLACE**  
**Bag with 100 towels SPUNLACE**



u.m.vta: 1		20	
------------	---	----	---

**REF. 03283**

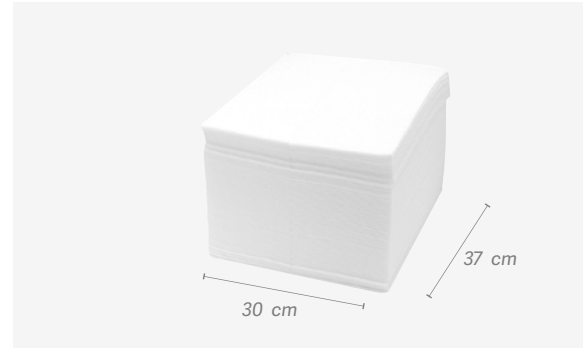
- Súper absorbentes
- Absorbent towels



**Protectores - pantalón**  
**Protectors - pants**

u.m.vta: 1		10	
------------	---	----	---

**REF. 06111**

Pantalón protector de polietileno de alta densidad para tratamientos estéticos como presoterapia o tratamientos en cabina con algas o fangos. Bolsa de 25 unidades.

*High density polyethylene protective pants for aesthetic treatments as presotherapy or seaweed/mud treatments in cabins. Bag 25 units.*



**100 Guantes polietileno transparente**  
**100 Transparent polyethylene gloves**

u.m.vta: 100		100
--------------	---	-----

**REF. 07804**



- 100% Polietileno virgen hdpe 0,7 +/- 2% g/pc
- Hipoalergénicos, impermeables, talla única
- EPI categoría 1
- Confeccionado y marcado CE, compatible con uso alimentario 2011/10/CE
- 30 cm. alto x 25 cm. ancho dedos x 15 cm. ancho muñeca

- 100% Hdpe virgin polyethylene 0,7 +/- 2% g/pc
- Hypoallergenic, unpermeable, one size
- Category EPI 1
- CE made & marked, compatible with food use 2011/10/CE
- 30 cm. high x 25 cm. width between fingers x 15 cm width wrist



### 100 Guantes un solo uso

#### 100 Disposable gloves

u.m.vta: 1  25 

80 g

REF. 07257

- Ambidiestro permite usar cada guante para cualquier mano
- Talla única
- Multiuso

- *Ambidextrous allows each glove to be used for any hand.*
- *One size*
- *Multipurpose*



### 100 guantes de un solo uso

#### 100 disposable gloves

u.m.vta: 1  1

REF.00680



Material: plástico LPDE polietileno de baja presión  
Características: lisos, incoloro  
Talla: grandes ambidiestros

*Material: low pressure LDPE polyethylene plastic*  
*Characteristics: smooth, colorless*  
*Size: large ambidextrous*



### Bolsa 100 guantes desechables

#### Bag 100 disposable gloves

u.m.vta: 1  100 

REF. 07304



### Bolsa 2 u. guantes profesionales

#### Bag 2 u. professional gloves

u.m.vta: 1  24

- Material: caucho
- Material: rubber

6,5  
Talla /Size

REF.01672

7  
Talle /Size

REF.01673

7,5  
Talla /Size

REF.01674



8  
Talla /Size

REF.01675



**Caja de 50 guantes sintéticos**  
**Box 50 synthetic gloves**

SIN polvo  
 Powder FREE

u.m.vta: 1		20	
------------	---	----	---

L

REF. 07264

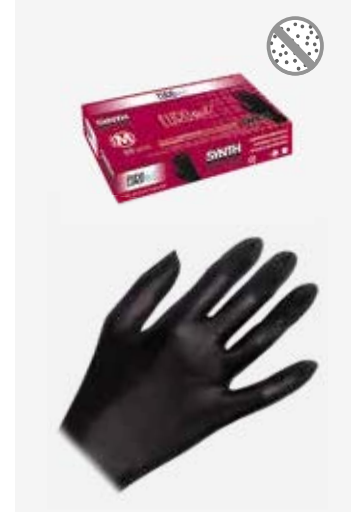

- Combina la flexibilidad del látex y la elasticidad del vinilo inodoro
- Sensación de una segunda piel gracias a sus propiedades elásticas muy similares al látex y ofrece las propiedades hipo alérgicas del vinilo.
- Material: derivado del PVC.
- No estériles
- Color negro
- Superficies interna y externa lisas
- Adecuados para alérgicos al látex

- *Combines the flexibility of latex and the elasticity of odorless vinyl*
- *Second skin sensation thanks to its elastic properties very similar to latex and offers the hypoallergenic properties of vinyl.*
- *Material: derived from PVC.*
- *Not sterile*
- *Black color*
- *Smooth internal and external surfaces*
- *Suitable for those allergic to latex*



**Caja de 100 guantes de látex blancos con poco polvo**  
**Box 100 white latex gloves with minimal powder**

SIN polvo  
 Powder FREE

u.m.vta: 1		10	
------------	---	----	---

S

REF. 01671

M

REF. 01669

L



REF. 01670



LÁTEX / LATEX  
 AQL 1,5

**Caja de 20 guantes de látex negros**  
**Box 20 black latex gloves**

SIN polvo  
 Powder FREE

u.m.vta: 1		24	
------------	---	----	---

S

REF. 02832

M

REF. 02833

L



REF. 02834



LÁTEX / LATEX  
 AQL 1,5

**Caja de 100 guantes de vinilo**  
**Box 100 vinyl gloves**

SIN polvo  
 Powder FREE

u.m.vta: 1		10	
------------	---	----	---

S

REF. 02586

M

REF.02587



VINILO / VINYL  
 AQL 1,5

### Pinza inox. Sobre uso general utensilios

#### Inox tweezer multi purpose

u.m.vta: 1  12

REF.04556



### Toalla 100% algodón

#### 100% cotton towel

u.m.vta: 12  48 

REF. 02947/58

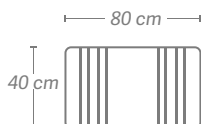

REF. 02901/58

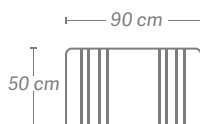

### Toalla manicura

#### Manicure towel

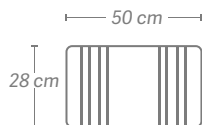

u.m.vta: 12  48

REF.00974



### Toalla 100% algodón

#### 100% cotton towel

u.m.vta: 1  12u.m.vta: 1  12380 g/m<sup>2</sup>

REF. 06570/58

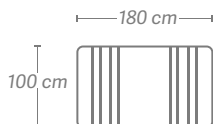
380 g/m<sup>2</sup>

REF. 06571/58

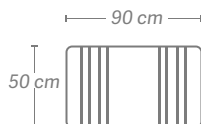

### Cepillo todo uso, colores

#### All purpose brush, colours

u.m.vta: 24  24

REF. 00129



### Cepillo ropa y tapicería

#### Clothes and tapestry brush

u.m.vta: 1  20 



REF.00893

Goma azul  
Blue rubber



## Sábanas protectoras

### Protective bed sheets



u.m.vta: 1  16 

REF. 06112



Sábanas de polietileno de alta densidad. 25 unidades de 180 x 200 cm. Para tratamientos de algas y fango

High density polyethylene sheets. 25 units of 180 x 200 cm. For algae and mud treatments

u.m.vta: 1  10 

REF. 06110





Sábanas de polietileno de alta densidad. 50 unidades de 180 x 200 cm. Para tratamientos de algas y fango

High density polyethylene sheets. 50 units of 180 x 200 cm. For algae and mud treatments

## Balanza spa mide la hidratación y el % de grasa corporal

### Spa balance to measure hydration and body fat (%)

u.m.vta: 1  6 

REF. 04805

- Capacidad: 150 kg
  - Escala: 6 a 150 kg
  - Unidad de ponderación: kg / lb / st
  - Dos pilas CR2032 (Incluidas)
  - Velocidad de pesada: velocidad media (aprox. dos segundos)
  - Apagado automático: 10 segundos
  - Cuando la batería este baja marcará en la pantalla "LO"
- Capacity: 150 kg
  - Scale: 6 to 150 kg
  - Weight unit: kg / lb / st
  - Two CR2032 batteries (included)
  - Weighing speed: average speed (two seconds approx.)
  - Automatic switch-off function: 10 seconds
  - When the battery is low, it will mark "LO" on the display



## Alfombrillas solarium

### Solarium mats

u.m.vta: 1  20 

Bolsa 50 alfombrillas solarium  
Bag 50 solarium mats

REF.03803



### Bolsa 10 Kimonos desechables

#### Bag 10 Disposable kimonos

u.m.vta: 1



10



28 g

REF. 07307/58



28 g

REF. 07307/50



- Medidas: 110 x 140 cm
- Material: non woven (tejido sin tejer)
- Lleva el cinturón en un bolsillo del brazo izquierdo
- Bolsa de 10 unidades

- Measurements: 110 x 140 cm
- Material: non-woven
- Has a belt in a left arm pocket
- Bag of 10 units

### Bolsa 100 peucos cubrezapatos

#### Bag 100 shoe covers

u.m.vta: 1



50

REF.07211

- Plástico
- Un solo uso
- Cerradas
- Un solo uso

- Disposable
- Plastic
- Close
- Single use



**Par de zapatillas suela goma**  
**Pair of rubber-sole slippers**

u.m.vta: 100  100

Abiertas  
 Open

**REF.02919**



Cerradas  
 Close

**REF.02920**



**Bolsa de 50 zapatillas**  
**Bag 50 slippers**

u.m.vta: 1  10



**REF.03807**



**REF.03808**



**Par de dos zapatillas pedicura**  
**Pair of two pedicure slippers**



u.m.vta: 1  12 

**REF. 06776**

- Surtido colores
- Assorted colours



**Bolsa de 12 Pares de zapatillas pedicura**  
**Bag of 12 pairs of pedicure slippers**



u.m.vta: 1  40 

**REF. 07432**



### Bolsa 100 cofias

#### Bag 100 caps

u.m.vta: 1  10 



10 g

**REF.07305**

- De un solo uso
- Plegados tipo acordeón
- Single use
- Folded accordion type

### Caja 100 diademas blancas

#### Box 100 white headbands

u.m.vta: 1  10 

**REF.07306**

- De un solo uso
- Single use



### Rollo papel crepado

#### Crepe paper roll

u.m.vta: 5  100

**REF.04420**





- Para diademas
- 100 servicios
- Especial estética
- Color rosa

- For headbands
- Roll 100 strips
- Special aesthetic
- Pink colour



### Bolsa 50 tangas hombre

#### Bag 50 thongs man

u.m.vta: 1	 20	
------------	--	---

REF.03216

- De un solo uso
  - Talla única
  - Elástico para adaptarse a cualquier medida
  - Color negro opaco
  - Ideal como complemento para depilación y tratamiento
- *Single use*
  - *One size*
  - *Elastic to adapt to any size*
  - *Opaque black*
  - *Ideal as a complement for hair removal and treatment*



### Bolsa 50 slips hombre

#### Bag 50 slips man

u.m.vta: 1	 10
------------	--

REF.03295

- De un solo uso
  - Talla única
  - Elástico para adaptarse a cualquier medida
  - Color azul opaco
  - Ideal como complemento para depilación y tratamiento
- *Single use*
  - *One size*
  - *Elastic to adapt to any size*
  - *Opaque blue*
  - *Ideal as a complement for hair removal and treatment*



### Bolsa 10 boxers caballero

#### Bag 10 boxers gentleman

u.m.vta: 1	 4
------------	---

REF.03802

- De un solo uso
- *Single use*



### Bolsa 100 tangas dama

#### Bag 100 thongs woman

u.m.vta: 1	 12
------------	--

REF.03483

- Elástico para adaptarse a cualquier medida
  - De un solo uso
  - Tira ancha
- *Elastic to adapt to any size*
  - *Single use*
  - *Wide strip*



### Bolsa 100 tangas mujer de hilo

#### Bag 100 thongs woman of thread

u.m.vta: 1	 12
------------	--



REF.01091

- Tira trasera muy estrecha
  - De un solo uso
- *Very narrow back strip*
  - *Single use*



### Pantalón presoterapia plástico

#### Plastic pressotherapy trouser

u.m.vta: 1  100 

REF.03694



- Sin elástico
- Color blanco
- De un solo uso

- No elastic
- White colour
- Single use

### Diadema esteticien

#### Head band beautician

u.m.vta: 10  100

REF. 01088



### Camiseta TASSEL

#### TASSEL shirt

u.m.vta: 1  50

M

REF.06284/2

L

REF.06284/3

XL

REF.06284/4

XXL

REF.06284/5



Camisetas de mujer en algodón. De color negro, cuello redondo y manga corta con el logo Tassel serigrafiado en el pecho. Disponibles en varias tallas. Cómodas, fáciles de combinar con cualquier look. Tejido resistente.

Women's shirts in cotton. Black, round neck and short sleeves with the Tassel logo printed on the chest. Available in several sizes. Comfortable, easy to combine with any look. Heavy duty fabric



### Gafa protectora antivaho Anti-fog protective goggles

u.m.vta: 1	 10
------------	--

REF.07256



- Protección para prevenir infecciones: protegen eficazmente de las salpicaduras, gavel, etc.
- Lugar de uso: cualquier lugar donde se requiere protección para los ojos.
- Diseño innovador cómodo. Se ajustan perfectamente a cualquier forma y tamaño de cabeza. Se pueden utilizar al mismo tiempo que sus gafas graduadas
- Certificado CE
- Material: plástico

- Protection to prevent infection: They effectively protect from splashing, gavel, etc.
- Place of use: any place where eye protection is required.
- Innovative and comfortable design. They fit any shape and size head perfectly
- They can be used with your prescription glasses
- CE-certified
- Material: plastic

### Alfombra desinfectante de calzado Shoe disinfectant mat

u.m.vta: 1	 12
------------	--

REF.07234



Alfombrilla extraplana de solo 1cm de alto para evitar tropiezos fabricada en polipropileno sobre una base de caucho y contenedor de aluminio ionizado. Medidas: 60 cm de ancho x 40 cm de largo x 1cm de alto/gosor.

Extra flat mat. Only 1cm high to avoid tripping. Made of polypropylene on a rubber base and ionised aluminium container. Measurements: 60 cm wide x 40 cm deep x 1 cm high/thick

Modo de uso: colocar la alfombra sobre una superficie plana y nivelada aplicar en la bandeja unos 700ml aproximadamente de líquido desinfectante. Se aconseja colocar un felpudo después de la bandeja para secar el calzado del cliente.

Instructions for use: Place the carpet on a flat, level surface and apply approximately 700 ml of disinfectant liquid to the tray. Place a mat after the tray to dry the customer's shoes.

### Caja 200 bastoncillos algodón con PALO PAPEL Box 200 ear buds cotton with PAPER STICK

u.m.vta: 1	 24
------------	--

REF.07261



### Bolsa algodón zigzag precortado Bag pre-cut zigzag cotton



u.m.vta: 20	 20
-------------	--

REF.02949





**Bolsa de 1 kg algodón en rollos**  
**Bag 1 Kg of rolled cotton**

Puntas incluidas  
 Tips included



u.m.vta: 1  12 

**REF. 00964**

u.m.vta: 1  12 



Anónimo  
 Anonymous

**REF. 00964/00**

u.m.vta: 1  12 

4 cortes de 8 cm  
 4 cuts of 8 cm

**REF. 04290**



u.m.vta: 1  10 

Plegado  
 Folded

**REF. 04288**





**Bolsa discos desmaquillar**  
**Bag make-up removal cotton discs**

u.m.vta: 24  24 

80 discos  
 80 discs

**REF. 07118**





u.m.vta: 1  24 



Anónimo  
 Anonymous



**REF. 07118/00**



**Espejo cromado redondo**  
**Round chromed mirror**

u.m.vta: 1	 60		Ø 10 cm
5x	7x	10x	
<b>REF.06716</b>	<b>REF.06717</b>	<b>REF.06718</b>	



u.m.vta: 1	 24		Ø 15 cm
5x	7x	10x	
<b>REF.06719</b>	<b>REF.06720</b>	<b>REF.06721</b>	

u.m.vta: 1	 24		Ø 18 cm
5x	7x	10x	
<b>REF.06722</b>	<b>REF.06723</b>	<b>REF.06724</b>	







**Espejo cromado redondo con 3 ventosas**  
**Round chromed mirror with 3 suction cups**

u.m.vta: 1	 48		Ø 15 cm	u.m.vta: 1	 24	
5x	7x	10x				
<b>REF.06725</b>	<b>REF.06726</b>	<b>REF.06727</b>				

u.m.vta: 1	 24		Ø 21 cm
5x	7x	10x	
<b>REF.06728</b>	<b>REF.06729</b>	<b>REF.06730</b>	







**Espejo cromado redondo con base**  
**Round chromed mirror with a base**

u.m.vta: 1	 12		u.m.vta: 1	 6	
Ø 15 cm			Ø 21 cm		
<b>7x</b>	<b>10x</b>		<b>7x</b>	<b>10x</b>	
<b>REF.06731</b>	<b>REF.06732</b>		<b>REF.06735</b>	<b>REF.06736</b>	







**Espejo pavonado con base**  
**Blued mirror with base**

u.m.vta: 1	 12		u.m.vta: 1	 6	
Ø 15 cm			Ø 21 cm		
<b>7x</b>	<b>10x</b>		<b>7x</b>	<b>10x</b>	
<b>REF.06733</b>	<b>REF.06734</b>		<b>REF.06737</b>	<b>REF.06738</b>	



**Espejo cromado redondo con pie y base**  
**Round chromed mirror with a foot and base**

u.m.vta: 1	 12		u.m.vta: 1	 6	
Ø 15 cm			Ø 21 cm		
<b>7x</b>	<b>10x</b>		<b>7x</b>	<b>10x</b>	
<b>REF.06739</b>	<b>REF.06740</b>		<b>REF.06741</b>	<b>REF.06742</b>	



**Espejo de pie metálico doble 5 aumentos / normal**  
**Metallic mirror with support double 5 magnifying**

Producto mejorado - Nuevo Packaging  
Improved product - New Packaging

u.m.vta: 1  6

5x  
**REF.02801**



5x  
**REF.02806**



Producto mejorado - Nuevo Packaging  
Improved product - New Packaging

u.m.vta: 1  12



5x  
**REF.02799**



5x  
**REF.02800**



### Espejo doble Double mirror



u.m.vta: 1		24	
------------	---	----	---

Mango y soporte  
Handle & support

REF. 01965



### Espejo redondo Round mirror

u.m.vta: 1		8	
------------	---	---	---

Professional  
Professional

REF. 00294/56

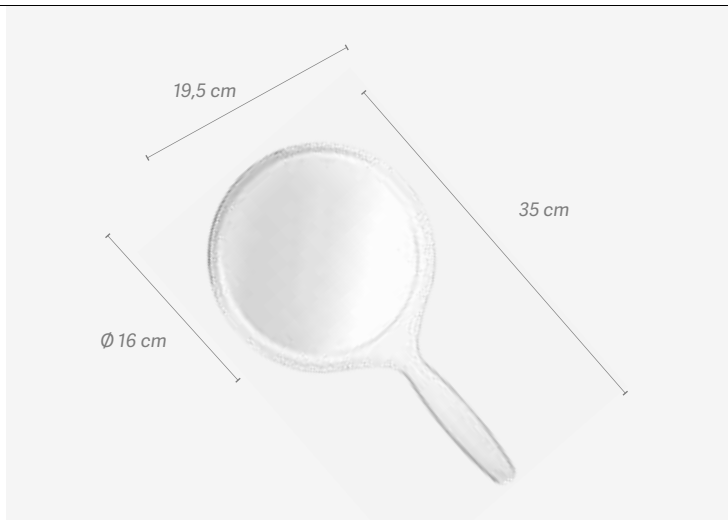

### Espejo espuma EVA EVA foam mirror



u.m.vta: 1		24
------------	---	----

REF.04742





**Espejos bolso**  
**Mirrors bag**

u.m.vta: 1		75	
------------	---	----	---

Modelo Capilla  
Model Chapel

**REF. 00265**

u.m.vta: 1		75	
------------	---	----	---

Cuadrado  
Square

**REF. 00268**

u.m.vta: 1		80	
------------	---	----	--



Cuadrado con asa  
Square with handle

**REF.00250**

u.m.vta: 1		30	
------------	---	----	---

**REF. 00266**

- Espejo redondo
- Normal/aumento
  
- Mirror round double
- Normal/magnifying

u.m.vta: 1		125	
------------	---	-----	---



**REF. 03073**

- Espejo polvera
- Normal/aumento
- Con peine
  
- Powder compact
- Normal/magnifying
- With comb



### Espejo redondo

#### Round mirror



u.m.vta: 1  100 

S

REF. 00263

### Espejo redondo

#### Round mirror

u.m.vta: 1  12 

NORMAL/X2 S

REF. 06620

NORMAL/X2 M

REF. 06621

NORMAL/X2 L

REF. 06622

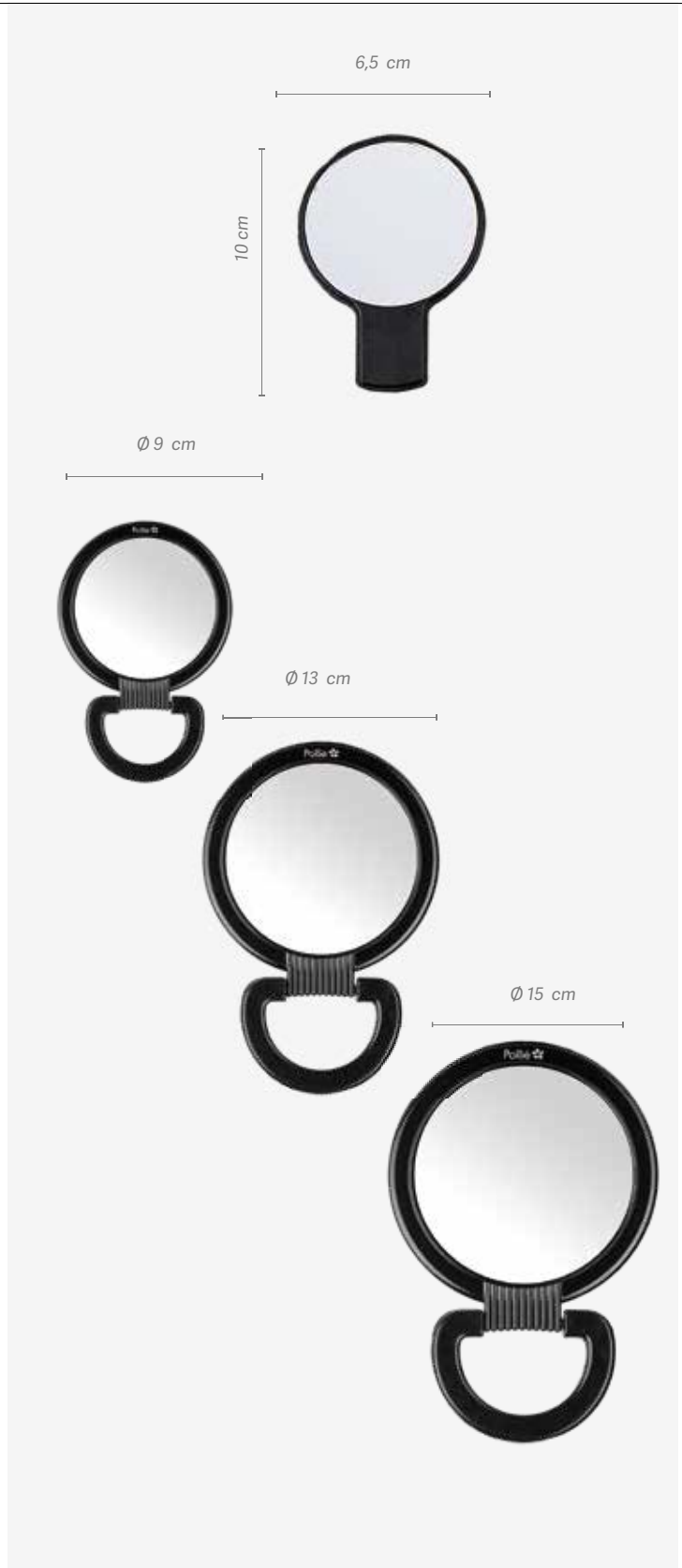

**Espejo camping**  
Camping mirror

u.m.vta: 1  12

**REF.00275**



u.m.vta: 12  12

**S**

**REF.00256**

**M**



**REF.00257**

**L**

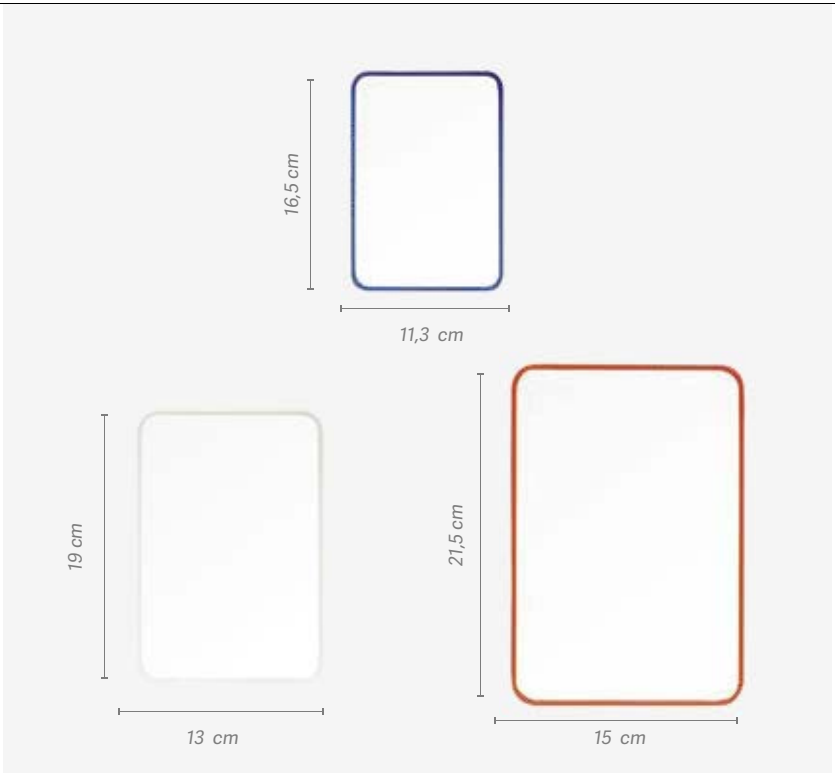
**REF.00258**



**Espejo T.V.**  
T.V. mirror

u.m.vta: 1  10 



**REF. 00254/50**

 **REF. 00254/58**

 **REF. 00255**



### Caja 50 mascarillas faciales higienicas Box of 50 hygienic facial masks

u.m.vta: 1  1 

REF. 07383



### Mascarilla higiénica 100% ALGODÓN ECOLÓGICO 30 usos reutilizable /lavable Hygienic mask 100% ECOLOGICAL COTTON 30 uses reusable/washable



u.m.vta: 1  36

REF. 07803

- 30 usos
- LAVABLE: Lavar a 60°, secar y planchar a 140° durante 10-15 segundos para activar el tratamiento. (Nº de lavados 30)
- 30 uses
- WASHABLE: Wash at 60°, dry and iron at 140° for 10-15 seconds to activate the treatment. (No of washes 30)



### Pantalla protectora facial Face shield

u.m.vta: 12  120 

REF. 07212

**ANTIVAHIO**  
Plástico transparente con espuma en la frente para una mayor comodidad

**ANTI-STEAM**  
Transparent plastic with foam on the forehead for greater comfort

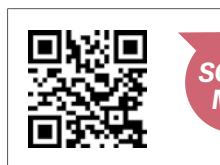
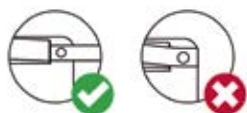
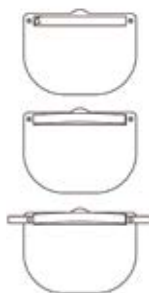

SCAN  
ME!



**Mascarilla reutilizable**  
**60 lavados**  
**Reusable mask**  
**60 washes**

- Reutilizables
- Certificadas
- Waterproof
- Transpirable
- Microfibra
- Equivalencia FFP-2
- LACLA Made in Spain

- Reusable
- Certified
- Waterproof
- Breathable
- Microfibre
- FFP-2 Equivalence
- LACLA Made in Spain

**Packs 6 mascarillas textiles unidades lisas**  
**Packs 6 fabric masks plain units**

u.m.vta: 1 20

Rosa  
Pink

REF. 07310

Beige  
Beige

REF. 07318

Blanca  
White

REF. 07319



**Packs 3 mascarillas textiles estampadas**  
**Packs 3 fabric masks stamped**

u.m.vta: 1 40

Mariposas  
Butterfly

REF. 07311

Corazón  
Heart

REF. 07312

Calavera  
Skull

REF. 07315

Topos  
Dots

REF. 07314

Militar  
Military

REF. 07313



## Casaca corazones

### Hearts jacket

u.m.vta: 1 40

**Negra**  
 Black
**MOD. 51605128**

Casaca manga mini con pinza de pecho y cuello mao. Contiene 1 bolsillo delantero, 1 bolsillo estampado y otro liso. Abrochada con botones de colores, prenda entallada con pinzas y con aberturas laterales. 100% poliéster

*Mini sleeve jacket with chest clip and mao collar. 1 front, 1 patterned pocket and a plain one. Buttoned with coloured buttons, fitted with tweezers and side slits. 100% polyester*

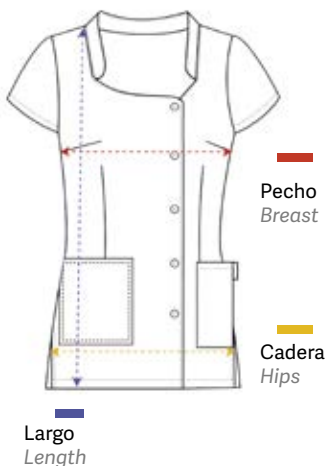

S	M	L	XL	XXL
98 - 102 cm	106 - 110 cm	114 - 118 cm	120 - 124 cm	126 - 130 cm
102 - 106 cm	108 - 112 cm	116 - 120 cm	124 - 128 cm	136 - 140 cm
72 - 74 cm	73 - 75 cm	75 - 77 cm	77 - 79 cm	78 - 80 cm
<b>REF.06297/50/1</b>	<b>REF.06297/50/2</b>	<b>REF.06297/50/3</b>	<b>REF.06297/50/4</b>	<b>REF.06297/50/5</b>

**Blanca**  
 White
**MOD. 51605128**

Casaca manga mini con pinza de pecho y cuello mao. Contiene 1 bolsillo delantero, 1 bolsillo estampado y otro liso. Abrochada con botones de colores, prenda entallada con pinzas y con aberturas laterales. 100% poliéster

*Mini sleeve jacket, with chest clip and mao collar. 1 front, 1 patterned pocket and a plain one. Buttoned with coloured buttons, fitted with tweezers and side slits. 100% polyester*

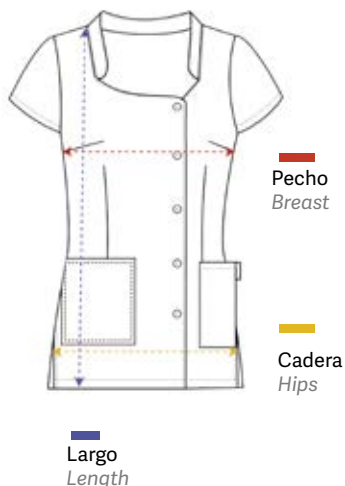

S	M	L	XL	XXL
98 - 102 cm	106 - 110 cm	114 - 118 cm	120 - 124 cm	126 - 130 cm
102 - 106 cm	108 - 112 cm	116 - 120 cm	124 - 128 cm	136 - 140 cm
72 - 74 cm	73 - 75 cm	75 - 77 cm	77 - 79 cm	78 - 80 cm
<b>REF.06297/58/1</b>	<b>REF.06297/58/2</b>	<b>REF.06297/58/3</b>	<b>REF.06297/58/4</b>	<b>REF.06297/58/5</b>





**Casaca vivo plata**  
**Live silver jacket**

u.m.vta: 1 40

Blanca  
White

**MOD. 52105640**

Casaca lisa de manga corta, cuello mao y canto delante con vivo de satén de color plata, delanteros con costadillos y bolsillos. Abrochado lateral con corchetes metálicos rectangulares, espalda con pinzas y aberturas laterales. Fácil de planchar. Poliéster muy transpirable.  
100 % poliéster fino

*Smooth jacket, mao collar and front edge with live satin silver, front with selvedges and pockets. Side fastening with rectangular metal brackets, back with clips, side openings, short sleeves. Easy to iron. Very breathable polyester. 100 % thin polyester*

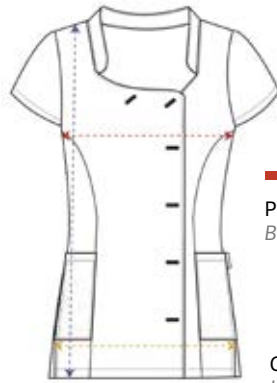

— Pecho  
Breast

— Cadera  
Hips

— Largo  
Length



**S**  
— 98 -102 cm  
— 104 -108 cm  
— 70 -72 cm

**M**  
— 106 -110 cm  
— 112 -114 cm  
— 70 -72 cm

**L**  
— 114 -118 cm  
— 118 -122 cm  
— 72 -74 cm

**REF.07552/58/1**

**REF.07552/58/2**

**REF.07552/58/3**



**MOD. 52105640**

Negra  
Black

Casaca lisa de manga corta, cuello mao y canto delante con vivo de satén de color plata, delanteros con costadillos y bolsillos. Abrochado lateral con corchetes metálicos rectangulares, espalda con pinzas y aberturas laterales. Fácil de planchar. Poliéster muy transpirable.  
100 % poliéster fino

*Smooth jacket, mao collar and front edge with live satin silver, front with selvedges and pockets. Side fastening with rectangular metal brackets, back with clips, side openings, short sleeves. Easy to iron. Very breathable polyester. 100 % thin polyester*

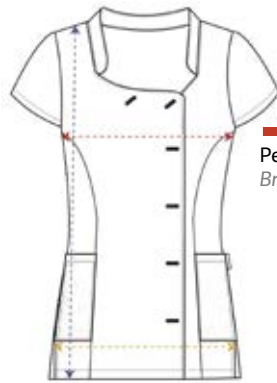

— Pecho  
Breast

— Cadera  
Hips

— Largo  
Length



**S**  
— 98 -102 cm  
— 104 -108 cm  
— 70 -72 cm

**M**  
— 106 -110 cm  
— 112 -114 cm  
— 70 -72 cm

**L**  
— 114 -118 cm  
— 118 -122 cm  
— 72 -74 cm

**XL**  
— 120 -124 cm  
— 126 -130 cm  
— 73 -75 cm

**REF.07552/50/1**

**REF.07552/50/2**

**REF.07552/50/3**

**REF.07552/50/4**



## Casaca buda Buddha jacket

u.m.vta: 1  40

### MOD. 51605109

Casaca manga japonesa con vivo a tono, pinza de pecho, cuello mao, 1 delantero estampado abrochado con corchetes lacados y 1 bolsillo liso. Espalda con pinzas traseras con atadores para regular la cintura, y las aberturas laterales. Fácil de planchar. Poliéster transpirable. 100% poliéster

Japanese sleeve jacket with vivid tone, with chest clip, mao collar, 1 printed front fastened with lacquered brackets, 1 plain pocket. Back with back clamps with tiers for regular waist, side openings. Easy to iron. Breathable polyester. 100% polyester



S	M	L	XL	XXL
94 - 98 cm	94 - 98 cm	106 - 110 cm	116 - 120 cm	118 - 122 cm
102 - 106 cm	102 - 106 cm	116 - 120 cm	124 - 128 cm	130 - 134 cm
71 - 73 cm	71 - 73 cm	75 - 77 cm	77 - 79 cm	75 - 77 cm
REF.06300/50/1	REF.06300/50/2	REF.06300/50/3	REF.06300/50/4	REF.06300/50/5

## Kimono antiestático Antistatic kimono

u.m.vta: 1  40

### MOD. 21300013 REF.06302/50



123 cm  
123 cm  
104 - 106 cm

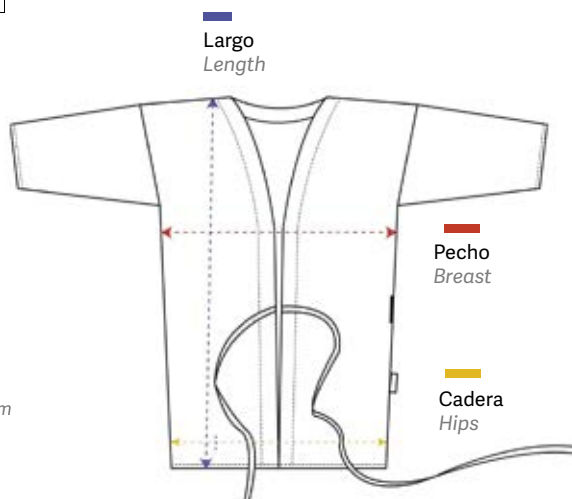

Kimono cruzado con cinturón y manga 3/4 con mini bolsillo en la manga. Fácil de planchar. Antidecoloración. 100% poliéster marroquí

Kimono crossed with belt, 3/4 sleeve with mini pocket on the sleeve. Easy to iron. Anti-discoloration. 100% marroquine polyester

### Chaqueta básica cremallera Basic zipper jacket

u.m.vta: 1 40

**MOD. 51308410**

Negra  
Black

Chaqueta básica sin mangas. Cierre con cremallera al costado. Composición 100% poliéster. Dos bolsillos, uno en la cintura y otro en el pecho. Recomendada para comercios y centros de estética

*Basic sleeveless jacket. Zip closure on the side. Composition 100% polyester. Two pockets, one at the waist and one on the chest. Recommended for shops and beauty centers*

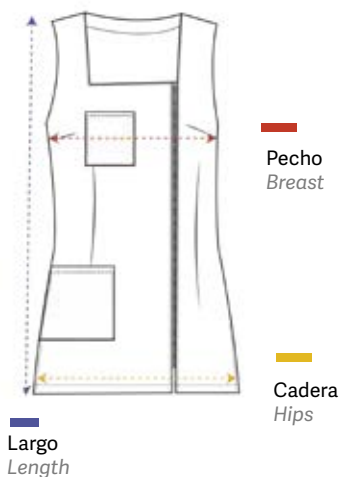

**S**

88 - 92 cm  
100 - 104 cm  
69 - 71 cm

**REF.06298/50/1**

**M**

94 - 98 cm  
104 - 108 cm  
71 - 73 cm

**REF.06298/50/2**

**L**

102 - 106 cm  
110 - 114 cm  
73 - 75 cm

**REF.06298/50/3**

**XL**

108 - 112 cm  
120 - 124 cm  
74 - 76 cm

**REF.06298/50/4**

**XXL**

116 - 120 cm  
128 - 132 cm  
76 - 78 cm

**REF.06298/50/5**

### Estola blanca mod White mod stole

u.m.vta: 1 40

**MOD. 213014601**

**REF.06553/58**

**1**  
UNICA

36 cm  
51 cm  
78 cm

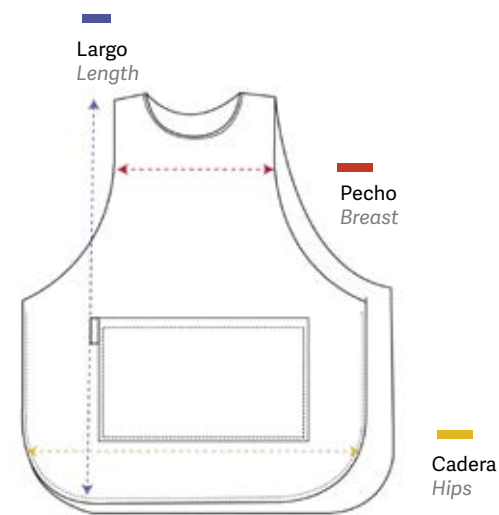

Estola 100% poliéster stretch. Ajustada por la espalda con un lazo y con bolsillos delanteros grandes y cómodos  
Stole 100% stretchy polyester. Adjusted at the back with a ribbon and with large and comfortable front pockets

## Estola cuello mao

### Mao neck stole

MOD.21602130

u.m.vta: 1  40

Estola con cuello mao con corchetes metálicos a presión, mini manga y delantero con costadillos y bolsillos. Es ajustable con cintas que se cruzan por la espalda y se anudan en la cintura.

Mao stole with metal snap fasteners, mini sleeve and front with selvedges and pockets. Waist adjustment with ribbons that cross at the back and are knotted at the waist.



100% poliéster  
100% polyester

REF.06309/50

100% poliéster  
100% polyester

REF.06309/63

100% poliéster  
100% polyester

REF.06309/68

50% poliéster , 50% algodón  
50% polyester , 50% cotton

REF.06309/72



36/37 cm  
59/60 cm  
75/76 cm

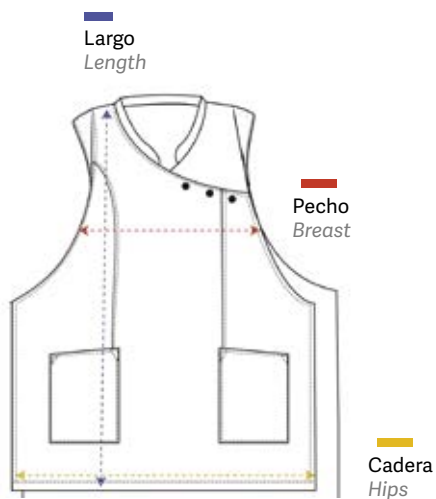

**Estola negra cuello V**  
**Black stole V Neck**

u.m.vta: 1 40

**MOD. 21602100**

**REF.07558**



- 36 cm
- 51 cm
- 78 cm

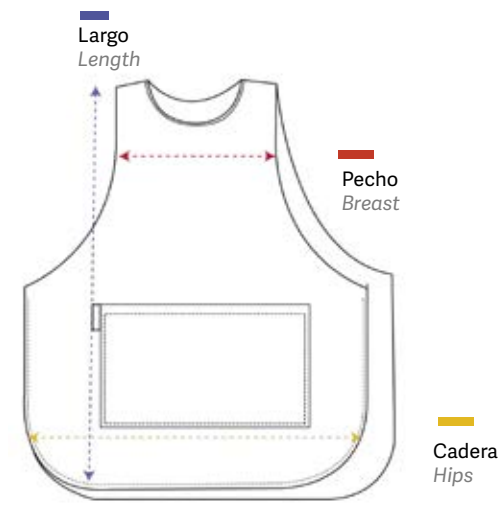

Estola 100% poliéster stretch. Ajustada por la espalda con un lazo y con bolsillos delanteros grandes y cómodos  
Stole 100% stretchy polyester. Adjusted at the back with a ribbon and with large and comfortable front pockets

**Pantalón mujer**  
**Women's pants**

u.m.vta: 1 40

**MOD. 41300011B**

- 67% poliéster
- 33% Algodón
- 67% polyester
- 33% cotton

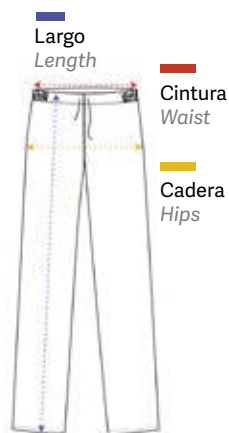

**S**

- 92-96 cm
- 92-96 cm
- 99-101 cm

**REF.06312/58/1**

**M**

- 98-102 cm
- 96-100 cm
- 101-103 cm

**REF.06312/58/2**

**L**

- 106-110 cm
- 106-110 cm
- 102-104 cm

**REF.06312/58/3**



**XL**

- 112-116 cm
- 114-118 cm
- 105-107 cm

**REF.06312/58/4**

## Aro luz LED 045 cm con trípode

### LED ring light 045 cm with tripod

u.m.vta: 1  5 

REF. 07003



- Anillo de luz led diametro 18"
- Peso neto anillo: 1,07 kg
- Color del anillo: negro
- Potencia: 50w
- Voltaje: ac100 / 240v
- Fuente de alimentación: cable de alimentación
- Cantidad de led: 288 cuentas led
- Temperatura de color: 2700k / 5700k
- Color del led: blanco puro / blanco natural / blanco cálido / blanco frío
- 2 Puertos usb
- Piezas: 1 pieza de anillo de luz led de 18" / 3 piezas de soportes para teléfono con manguera / 1 pieza remoto
- Obturador bluetooth / 1 pieza de 2,5m. Soporte trípode vertical / 1 bolsa de transporte
- Embalaje: anillo de luz separado empacado junto y trípode embalado junto

- Led ring light diameter 18"
- Ring light net weight: 1,07 kg
- Ring color: black
- Power: 50w
- Voltage: ac100/240v
- Power supply: power cord
- Led q'ty: 288 led beads
- Colour temperature: 2700k/5700k
- Led color: pure white/natural white/warm white/cold white
- 2 Usb ports
- Parts: 1 pc of 18" led ring light/3 pcs of hose phone holders/ 1 pcs remote
- Bluetooth shutter/1 pc of 2,5m. Upright tripod stand/1 of carry bag
- Packaging: separated ring light packed together & tripod packed together



## Aro luz LED 026 cm sobremesa con trípode LED ring light 026 cm desktop with tripod

u.m.vta: 1  10 

REF. 07293

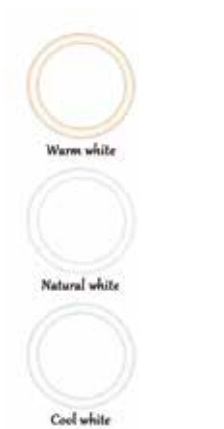

- Diámetro de luz led anillo. 10"
- Peso neto anillo : 0,24 kg
- Color del anillo: negro
- Potencia: 8/12 w
- Voltaje: ac85 / 240v
- Fuente de alimentación: alimentado por usb
- Cantidad de led: 120 cuentas led
- Temperatura de color: 3000k / 6500k
- Color del led: blanco puro / blanco natural / blanco cálido / blanco frío
- Piezas: 1 anillo de luz led de 10" / 1 soporte de trípode de escritorio de 14 cm / 1 manguera
- Soporte para teléfono / 1 cabezal de bola / 1 clip para teléfono / 1 unidad bluetooth
- Obturador / 1 pieza porta teléfono ajustable / 1 pieza 1,6 trípode / 1 bolsa de transporte

- Led ring light diameter. 10"
- Ring light net weight: 0,24 kg
- Ring colour: black
- Power: 8/12w
- Voltage: ac85/240v
- Power supply: usb powered
- Led q'ty: 120 led beads
- Color temperature: 3000k/6500k
- Led colour: pure white/natural white/warm white/cold white
- Parts: 1 pc 10" led ring light/1 pc 14 cm desktop tripod stand/1 pc hose
- Phone holder/1 pc ball head/1 pc phone clip/1 pc remote bluetooth
- Shutter/1 pc adjustable phone holder/1 pc 1,6 tripod/1 carry bag

## Maletín utiles Briefcase tools

u.m.vta: 1	 1
------------	---

●  
REF. 07320/50



●  
REF. 07320/63

●  
REF. 07321/50



●  
REF. 07321/63

- Material: Polipiel
- Ideal para almacenar productos de maquillaje y pequeños utensilios
- Cierre: cremallera

- Material: Leatherette
- Ideal for storing makeup products and small utensils
- Closure: zipper

## Maletas aluminio Aluminium suitcases

Todas las maletas se venden vacías  
All the cases sold empty

u.m.vta: 1  4

Para útiles, interior 6  
compartimentos y 4  
bandejas

For tools, 6  
compartments and  
4 trays



**REF.03598**



**REF.03599**

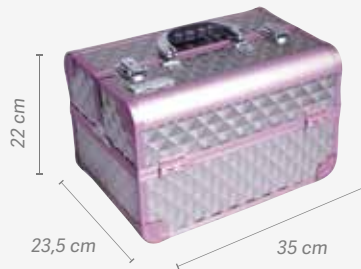

u.m.vta: 1  6

**REF.02318**



u.m.vta: 1  4

**REF.02317**



### Maleta aluminio Aluminium suitcase

u.m.vta: 1	 4
------------	---

Todas las maletas se venden vacías  
All the cases sold empty

**REF.01492**



### Maleta PVC negra Black PVC suitcase

u.m.vta: 1	 4
------------	---

Todas las maletas se venden vacías  
All the cases sold empty

**REF.02925**



### Conjunto 3 maletas surtidas PVC Set 3 PVC suitcases

u.m.vta: 1	 4
------------	---

Todas las maletas se venden vacías  
All the cases sold empty

**REF.02594**

### Maleta trolley Trolley suitcase

u.m.vta: 1	 1
------------	---

Con compartimentos y espejo  
With compartments and mirror



**REF.03814/50**



## Maleta maquillaje, cosmética y estética Make-up cosmetic and aesthetic suitcase

u.m.vta: 1		4
------------	---	---

Con 4 bandejas extraíbles y con 12 compartimentos variables. Cuenta con un amplio espacio en el interior para los productos más grandes. Incluye dos bombines y dos llaves de recambio.

*With 4 removable trays and 12 adaptable compartments due to the separators. There is a large space inside to keep bigger products. It includes two cylinder locks and two replacement keys.*



REF.04940/50



REF.04940/54



REF.04940/70



u.m.vta: 1		4
------------	---	---

Con bandejas extraíbles (2 en cada lateral). Cada bandeja tiene 4 compartimentos. Gran espacio interior clasificable en 4 apartados. Incluye en su interior una banda para colgar la maleta al hombro y dos bombines con dos llaves de recambio.

*With removable trays (2 in each side). Each tray has 4 compartments. Large inner space divided in 4 sections. It includes inside a band to hang the suitcase on the shoulder and two bowlers with two spare keys.*



REF.04941/50



REF.04941/54



REF.04941/70



### Maleta maquillaje, cosmética y estética Make-up, cosmetic and aesthetic suitcase

u.m.vta: 1	 4
------------	---

REF.04942/50





REF.04942/54

Con bandejas extraíbles (2 en cada lateral). Cada bandeja tiene 4 compartimentos. Gran espacio interior clasificable en 4 apartados. Incluye en su interior una banda para colgar la maleta al hombro y dos bombines con dos llaves de recambio.

With removable trays (2 in each side). Each tray has 4 compartments. Large inner space divided in 4 sections. It includes inside a band to hang the suitcase on the shoulder and two bowlers with two spare keys.

### Bolsa porta-útiles negro Black handbag for tools

u.m.vta: 1	 6	
------------	---	---

REF. 02516





## Maleta trolley 4 cuerpos 4 section trolley suitcase

Todas las maletas se venden vacías  
All the cases sold empty

u.m.vta: 1		1
------------	---	---

La maleta trolley de Pollié está creada en base a una estructura de 2 cuerpos modificables, pensado para facilitar el almacenaje al profesional de sus utensilios de peluquería, maquillaje o cosmética.

La parte superior de la maleta consta de tres bandejas extraíbles. Cada una de ellas está dividida en tres compartimentos.

A su vez, en una de ellas, encontrarás doce espacios circulares pensados para almacenar las lacas de uñas y así evitar su desprendimiento, facilitando su transporte con total seguridad. Asimismo, el interior del cuerpo superior puede ser modificado según sus necesidades, variando la estructura de los compartimentos. Para finalizar, su función 2 en 1 les permitirá disponer de una maleta de mano, o bien si lo prefieres colgártela al hombro, gracias a su tira de nylon.

La parte inferior de la maleta tiene una bandeja extraíble con opción de 4 compartimentos también modificables gracias a los separadores. El cuerpo inferior, con gran capacidad en su interior, les dará la opción de un transporte más ligero, ya que se puede convertir en una maleta más pequeña, con tapa y espejo incorporado. Las ruedas son intercambiables mediante la pestaña de enganche. El trolley dispone de dos bobinas y dos llaves de recambio.

*The trolley suitcase of Pollié is created based on a structure of 2 modifiable bodies, designed to facilitate the professional storage of your hairdressing, make-up or cosmetic utensils.*

*The top of the suitcase consists of three removable trays. Each of them is divided into three compartments. So, in one of them, you will find twelve circular spaces designed to store nail lacquers and thus prevent their detachment, facilitating their transport with total security. Also, the interior of the upper body can be modified according to your needs, varying the structure of the compartments. Finally, its 2-in-1 function will allow you to have a handbag, or if you prefer to hang it on the man, thanks to its nylon strip.*

*The lower part of the suitcase has a removable tray with the option of 4 compartments that can also be modified thanks to the spacers. The lower body, with large capacity inside, will give you the option of lighter transport, since it can be converted into a smaller suitcase, with a lid and mirror incorporated in it. The wheels are interchangeable using the hitch tab. The trolley has two coils and two spare keys.*



REF.04939/50



REF.04939



**Caja organizadora**  
**Organizer box**

Vacía  
Empty

u.m.vta: 1  24

REF.04722



u.m.vta: 1  12

REF.04309

Imantada  
With magnet



**Pulverizador de colores transparente**  
**Transparent color spray**

u.m.vta: 12  84 

300 ml

    
REF.01372

330 ml

    
REF.00959

Redondo  
Round

300 ml

    
REF.01484

300 ml

   
REF.01663



**Tarjetero aluminio**  
**Aluminium card case**

u.m.vta: 1  400

**REF.02470**



**Botella bomba dosificadora**  
**Measuring pump bottle**

u.m.vta: 20  80

240 ml

**REF.02880**



**Protector ocular UV lente con estuche**  
**UV eyes protectors w/lens kit**

u.m.vta: 10  100

Incluye una lente central que permite la visión  
*Includes a central lens that allows vision*

**REF.03195**

Sin visión  
*Without vision*

**REF.03194**



- Modelo que incluye novedoso sistema de sujeción especial basado en horquilla transparente de fibra de plástico
- Con estuche para guardar el protector

- Model that includes a new special clamping system based on a transparent plastic fiber fork
- With case to store the protector

**Artículos de venta exclusiva EN ESPAÑA**  
*Those product are sold exclusively IN SPAIN*



**Antiséptico daromix GH**  
**Daromix GH antiseptic**

u.m.vta: 1  12

1 L

REF.06200

**Desinfectante Limoseptol**  
**Limoseptol disinfectant**

u.m.vta: 1  20 

50 ml

REF. 06151

u.m.vta: 1  20

1 L

REF.06150



- N° Registro AEMPS: 905-DE5
- Antiséptico hidroalcohólico para desinfección higiénica de manos por fricción
- Eficacia garantizada científicamente
- Amplio espectro biocida a partir de 30 seg
- Fórmula hipoadérgica
- Preserva la hidratación de la piel
- No irritante cutáneo
- Seca rápidamente
- Eficaz como: bactericida, levuricida, virucida y microbactericida



- *Water alcohol antiseptic for hygienic friction disinfection*
- *Registration number AEMPS: 905-DE5*
- *Scientific efficiency guaranteed*
- *Wide biocide range from 30 sec*
- *Hypoallergenic formula*
- *Preserves skin hydration*
- *No skin irritation*
- *Quick drying*
- *Effective as: bactericide, levuricide, virucidal and microbactericide*



- N° Registro AEMPS: 47-DE5
- Producto de gran alto nivel desarrollado exclusivamente para la higiene, limpieza y desinfección, para utensilios profesionales de salones de belleza
- Acción detergente - amplio espectro
- Biodegradable -sin fosfatos y SIN FORMOL
- Eficacia germicida y DESINFECTANTE frente a: bacterias, levaduras y hongos
- Dosis de mezcla
- 100 ml producto = 10 litros de agua

- *Registration Number AEMPS: 47-DE5*
- *High level product developed exclusively for the hygiene, cleaning and disinfection for professional utensils of salons of beauty*
- *Detergent action - wide spectrum*
- *Biodegradable - no phosphates/formol*
- *Disinfectant and germicide efficiency against bacterias, yeast and funguses*
- *Mixing dose*
- *100 ml product = 10 liters of water*

### Botella especial para gel y solución hidroalcohólica Special bottle for gel and sanitising solution

u.m.vta: 1  3 



Con soporte para pared  
With wall bracket

300 ml

REF.07280



### Higienizante de superficies en spray Surface sanitiser spray

u.m.vta: 1  12 

500 ml

REF.07232

Ideal para la higienización y limpieza de cualquier tipo de superficie: metálica, plástica, cristal y cerámica.

- Mobiliario, puertas, barandillas, juguetes, inodoros, Teclados de ordenadores, ratones, pantallas...Puestos de trabajo

#### CARACTERÍSTICAS Y VENTAJAS

- Inocuo en contacto con la piel
- Rápida y efectiva acción de limpieza e higienización
- Evapora completamente, sin dejar residuo
- No ataca plásticos ni gomas

*Ideal for sanitising and cleaning any type of surface: metal, plastic, glass and ceramics.*

- Furniture, doors, railings, toys, toilets, computer keyboards,
- mice, screens...Workstations

#### FEATURES AND ADVANTAGES

- Harmless in contact with the skin
- Fast and effective cleaning and sanitising action
- Evaporates completely, leaving no residue
- It does not attack plastics or rubbers



## Jabonera plástico

### Plastic soap case

u.m.vta: 1	 40
------------	--

REF.02197

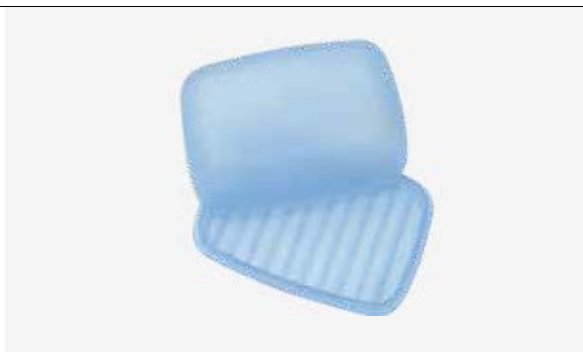

## Desatascador con fuelle w.c

### Unblocker with cushion w.c

u.m.vta: 10	 10
-------------	--

REF.00931



## Mango para escoba

### Broom handle

Rosca española e italiana  
Spanish and Italian thread

u.m.vta: 12	 12
-------------	--

REF.01131

- De fácil limpieza y larga durabilidad
- Soporte de plástico
- Ideal para todo tipo de suelos, en especial el parquet

- Easy cleaning and long durability
- Plastic support
- Ideal for all types of floors, especially wood floor



u.m.vta: 10	 10
-------------	--

REF.01365

- Telescópico extra
- Extra telescopic





## Escobas de goma Rubber brooms

u.m.vta: 4		16
------------	---	----

Con lengüeta  
With thread

**REF.01223**



u.m.vta: 5		20	
------------	---	----	---

**REF. 01285/50**



u.m.vta: 5		20
------------	---	----

**REF.02420**



- De fácil limpieza y de larga duración, la eficacia del diseño de sus púas logra arrastrar el polvo sin levantarlo, por lo que es ideal para personas alérgicas ya que favorecen a un ambiente limpio
- Easy to clean and long-lasting, the effectiveness of the design of its spikes manages to drag the dust without lifting it, making it ideal for allergy sufferers as they favor a clean environment

TASSEL

08

## Mobiliario Furniture

*Camillas, taburetes, sillas, soportes,  
carritos, maletines, sillas de maquillaje...*

*Massage tables, stools, chairs, supports,  
trolleys, make-up cases, make-up chairs...*



### Camilla masaje portátil

#### Portable massage table

u.m.vta: 1		1
------------	---	---

Peso: 17,5 kg  
Weight: 17,5 kg

**REF.07384**



### Camilla masaje portátil

#### Portable massage table

u.m.vta: 1		1
------------	---	---

- Aluminio
- Peso: 16 kg



- Aluminium
- Weight: 16 kg

**REF.07385**



### Camilla masaje estructura metálica

#### Massage table metal structure

u.m.vta: 1  1 

**REF.02738**





- Densidad de esponja: 30kg/m<sup>3</sup>
- Peso: 17 kg

- Sponge density: 30kg/m<sup>3</sup>
- Weight: 17 kg

### Camilla especial masaje

#### Special massage table

u.m.vta: 1  1 

**REF. 02739**

**REF. 02739/50**



- Densidad de esponja: 30kg/m<sup>3</sup>
- Peso: 31 kg

- Sponge density: 30kg/m<sup>3</sup>
- Weight: 31 kg

### Porta rollo papel camilla

#### Paper roll holder for massage table

u.m.vta: 1  5



Soporte para pared  
Wall bracket

**REF.01168**



### Camilla hidráulica 3 cuerpos

#### Hydraulic massage table 3 bodies

u.m.vta: 1  1 

**REF. 03031**

- Densidad de esponja: 162 kg/m<sup>3</sup>
- Con agujero facial bajo el cojín del reposacabezas
- Espesor pvc 1.1 / 1.2 cm
- Espuma blanca 1ª calidad
- Cómoda, sólida y versátil
- Peso: 62 kg

- *Sponge density: 162 kg/m<sup>3</sup>*
- *Features a hole for the face beneath the head rest cushion*
- *1.1 / 1.2 cm - thick PVC*
- *Top quality white foam*
- *Comfortable, rugged and versatile*
- *Weight: 62 kg*



### Camilla eléctrica 3 cuerpos

#### Electric massage table 3 bodies

u.m.vta: 1  1

**REF.03030**

- Densidad de esponja: 162 kg/m<sup>3</sup>
- Brazos extraíbles
- Con agujero facial bajo el cojín del reposacabezas
- Espuma blanca 1ª calidad
- Asiento 9,5 cm
- Cómoda, sólida y versátil
- 3 cuerpos- 3 motores
- Soporta 200 Kg
- Peso: 70 kg

- *Sponge density: 162 kg/m<sup>3</sup>*
- *Removable arms*
- *Features a hole for the face beneath the head rest cushion*
- *Top quality white foam*
- *9.5 cm seat*
- *Comfortable, rugged and versatile*
- *3 bodies - 3 motors*
- *Can hold up to 200 Kg*
- *Weight: 70 kg*



### Camilla spa Massage table spa

u.m.vta: 1	 1
------------	---

REF.03032

- Apoyacabezas NO desmontable
- Peso: 53 kg
- Headrest CAN NOT be disassembled
- Weight: 53 kg



### Esclerilla madera spa Wooden steps spa

u.m.vta: 1	 1
------------	---

REF.03072





**Biombo madera spa**  
**Wooden screen spa**

u.m.vta: 1  1

**REF.03078**



**Estantería madera spa**  
**Wooden shelves spa**

u.m.vta: 1  1

**REF.03071**



## Mesa manicura Manicure table

u.m.vta: 1  1

REF.02139

- Mesa manicura compuesta de tablero en madera blanco, pie de aluminio y mueble termoconformado con ruedas
- Incluye lámpara, espuma apoyamanos y un práctico organizador de útiles
- Sin aspirador
- Peso: 22 kg

- *Manicure table made up of a white wooden board, an aluminium base and a thermoformed piece of furniture with wheels*
- *Includes a lamp, a foam palm rest and a handy organiser for tools*
- *Weight: 22 kg*
- *Vacuum cleaner not included*



## Mesa manicura con aspiración Vacuum manicure table

u.m.vta: 1  1

REF.03067

- Mesa manicura compuesta de tablero en madera blanco, pie de aluminio y mueble termoconformado con ruedas
- Incluye lámpara, espuma apoyamanos y un práctico organizador de útiles
- Con aspirador 20W
- Peso: 22kg

- *Manicure table made up of a white wooden board, an aluminium base and a thermoformed piece of furniture with wheels*
- *Includes a lamp, a foam palm rest and a handy organiser for tools*
- *Includes a 20W vacuum cleaner*
- *Weight: 22kg*



### Mesa manicura plegable con aspiración y ruedas

#### Folding manicure table with vacuum and wheels

u.m.vta: 1		1
------------	---	---

REF.04278

- Con aspirador de 3000 rpm  
30 W
- Peso: 12 kg
- Vacuum cleaner 3000 rpm  
• 30 W
- Weight: 12 kg



### Mesa manicura en madera blanca

#### White wooden manicure table

u.m.vta: 1		1
------------	---	---



- Peso: 33 kg
- Weight: 33 kg

REF.03934



### Carrito estética Pollié

#### Polié beauty trolley

u.m.vta: 1		1	
------------	---	---	---

- Peso: 12 kg
- Weight: 12 kg

REF. 02839



SCAN  
ME!



## Lámpara mesa manicura Manicure table lamp

u.m.vta: 1	 1
------------	---

REF.03187

- Lámpara en color aluminio
- Luz de neón
- Medida: 72 cm
- Se suministra con fluorescente de 20W y recambio adicional

- Aluminum coloured lamp
- Neon light
- Measure: 72 cm
- Supplied with fluorescent 20W and additional spare



## Carrito manicura/pedicura Manicure/pedicure trolley

u.m.vta: 1	 1
------------	---

REF.03944/50

REF.03944/58



### Mostrador recepción de madera y metal efecto espejo

#### Wood and metal reception desk with mirror effect

u.m.vta: 1  1

**REF.03935**

Con compartimentos interiores de madera para almacenaje y repisa

With a shelf and interior wooden compartments for storage



### Sofa espera 3 plazas

#### 3 seater waiting sofa

u.m.vta: 1  1

En polipiel

In black imitation leather

**REF.03950**



### Recepción EARTH

#### EARTH reception

u.m.vta: 1  1

Grafito · Graphite



**REF.04518/50**

Roble · Oak



**REF.04518/65**

Blanco · White



**REF.04518/58**

- Laminado
- Con estantes regulables y 1 cajón

- Laminated
- With adjustable shelves and 1 drawer



### Taburete STREET

#### STREET stool

u.m.vta: 1  1

REF.06103/50

SCAN  
ME!

REF.06103/58



Taburete STREET clásico con bomba hidráulica para regular la altura a la deseada en cada trabajo

STREET classic stool with hydraulic pump to regulate the height to the desired one in each work

**Comparativa 04419 - 06103**  
Comparative 04419 - 06103



### Taburete base metal

#### Metal base stool

u.m.vta: 1  1

REF.04419/50

SCAN  
ME!

REF.04419/58



### Taburete RODEO

#### RODEO stool

u.m.vta: 1  1

REF.01964





**Taburete URBAN**  
**URBAN stool**

u.m.vta: 1  1

● **REF.06102/50**

Taburete URBAN ergonómico con bomba hidráulica para regular la altura a la deseada en cada trabajo. Su forma se adapta al cuerpo y como consecuencia propicia una mejor postura y evita los dolores de espalda después de muchas horas de trabajo

○ **REF.06102/58**

URBAN stool ergonomic with hydraulic pump to regulate the height to the desired one in each work. Its ergonomic shape adapts to the shape of the body and as a consequence a better posture of the back that can avoid pain after many hours of work



SCAN ME!



**Comparativa 04382 - 06102**  
**Comparative 04382- 06102**



**Taburete RODEO base metal**  
**RODEO metal base stool**

u.m.vta: 1  1

● **REF.04382/50**



○ **REF.04382/58**



SCAN ME!



**Silla reclinable**  
**Reclining chair**

u.m.vta: 1  1 

○ **REF. 02975/58**

- Reclinable 130° / hidráulica
- Anchura de brazo a brazo: 57 cm
- Anchura cabezal de la silla: 19 cm
- Respaldo: 51 x 41 cm
- Altura cabezal: 13 cm
- Distancia entre respaldo y cabezal: 14 cm
- Peso: 32,5 kg
- Cabezal extraíble con una posición

- Reclining 130° / hydraulics
- Width from arm rest to arm rest: 57 cm
- Width of chair head: 19 cm
- Backrest: 51 x 41 cm
- Head height: 13 cm
- Distance between backrest and head: 14 cm
- Weight: 32,5 kg
- Removable head with one position



### Silla con respaldo y regulación

#### Backed chair with height adjustment

u.m.vta: 1  1



REF.02730/58



### Silla con regulación

#### Chair with height adjustment

u.m.vta: 1  1



REF.02732



REF.02732/58



### Silla con respaldo y regulación

#### Backed chair with height adjustment

u.m.vta: 1  1



REF.03937/50



REF.03937/58

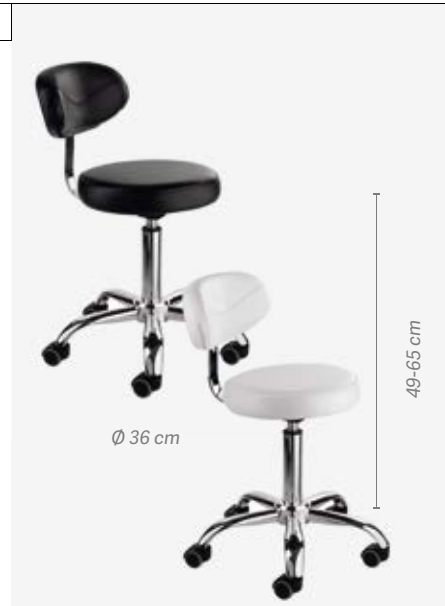

### Silla con respaldo FASHION

#### FASHION backed chair

u.m.vta: 1  1



REF.06101/58

Silla FASHION con respaldo para más comodidad y apoyo de la espalda. Las ruedas están diseñadas para evitar que el cabello se quede enganchado en ellas. Son fáciles de limpiar

*FASHION backed chair for more comfort and support of the back. The wheels are designed to prevent the hair from getting caught in them. They are easy to clean*



SCAN  
ME!



### SopORTE tattoo

#### Tattoo holder

u.m.vta: 1	 1
------------	---

REF.04915



- Reglable y basculante
- Tapizado: 37 x 21 cm

- Adjustable and tilting
- Upholstery: 37 x 21 cm

### Apoya nuca

#### Neck support

u.m.vta: 1	 1
------------	---

REF.03842



- Tapizado: 23 x 6 cm
- Upholstery: 23 x 6 cm

### SopORTE pedicura

#### Pedicure holder

u.m.vta: 1	 1
------------	---

REF.03627

- Soporte pedicura 20 x 17 cm
- Basculante
- 1,94 kg

- Pedicure holder 20 x 17 cm
- Tilting
- 1,94 kg



### Silla masaje Massage chair

u.m.vta: 1  1



REF.02740/50



REF.02740



### Silla especial pedicura con bañera para pies Special pedicure chair with a basin for the feet

u.m.vta: 1  1 

REF. 02741

- Mantiene el agua caliente con burbujas.
- Keeps the water hot with bubbles.

### Sillón pedicura spa Pedicure spa chair

u.m.vta: 1  1

REF. 07341

- Con reposaesplada ajustable
- With adjustable backrest



### Maletín tocador maquillaje Make-up stand case

u.m.vta: 1  1

Tocador de maquillaje con 6 luces y ruedas plegables. Convertible en cómoda maleta trolley + 2 cubiletes para pinceles. Clavija europea.

*Make-up stand with 6 lights and folding wheels and convertible in a comfy case + 2 beakers for cosmetic brushes. European plug.*

17 kg

**REF.04937/50**



### Maletín tocador maquillaje Make-up stand case

u.m.vta: 1  1

17 kg

**REF.04937/54**



## Reposa cabezas negro Black headrest

u.m.vta: 1  6

REF.06157

- Solo apto para ref. 06156/50 y 06156/54
- Only suitable for ref. 06156/50 and 06156/54



## Silla maquillaje plegable Folding make-up chair

u.m.vta: 1  1



REF.06156/50



REF.06156/54

- Ideal para maquillaje
- Ideal for make-up

**Incluye funda de transporte**  
**Includes transport case**





### Colgador ventosa

#### Suction pad hanger

u.m.vta: 15  15

**REF.02904**

- Bolsa dos colgadores ventosa
- Bag with two suction cup hangers

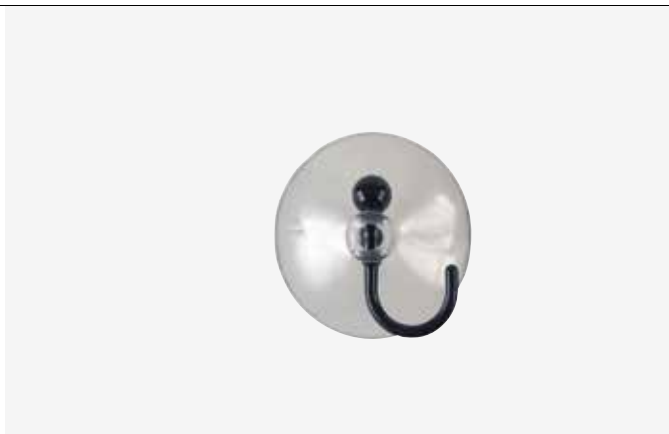

### Organizador toallas

#### Towels organizer

u.m.vta: 1  6

**REF.04378**

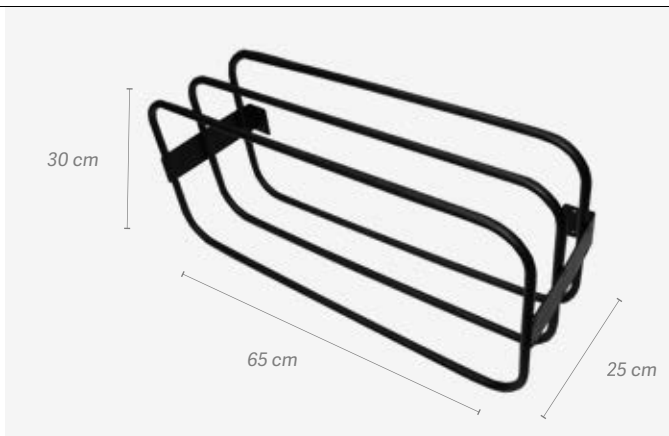

### Contenedor toallas

#### Towels container

u.m.vta: 1  4

**REF.03159**

- Con ruedas
- Bolsa contenedora lavable
- Estructura de acero inoxidable
- Features wheels
- Washable containing bag
- Stainless steel structure



ACCESORIOS	817	CEPILLOS PARA PLANCHA	278
ACCESORIOS CERA	622-623	CEPILLOS PLANOS DESENREDAR	277
ACCESORIOS CERA ROLL-ON	628-629	CEPILLOS RAGNAR	479
ACCESORIOS COSMÉTICA	609	CEPILLOS TÉRMICOS	283-284
ACCESORIOS MANICURA	721	CEPILLOS TÉRMICOS CERÁMICOS	282
ACCESORIOS NAIL ART	663-673	CEPILLOS TÉRMICOS DE ALUMINIO	285
ACCESORIOS TINTE	59-60	CEPILLOS TÉRMICOS IÓNICOS	282
ACCESORIOS TORNOS	685	CERA	615-616
ACCESORIOS Y KITS POLLÍE	652	CERA CAPTAIN COOK	505
ACCESSORIOS COSMÉTICA	680	CERA FORMATO KG	611-614
ACEITE PARA BARBA	509	CERA FORMATO ROLL-ON	624-627
ACEITES	436	CERILLAS HEMOSTÁTICAS	516
ACEITES BASE	601-603	CHAMPÚ BOURBON 1874	504
ACEITES CAPTAIN COOK	505	CHAMPÚ CAPTAIN COOK	499
ACEITES ESENCIALES	592-595	CHAMPÚ HYALURONIC	144
ACRYLIC GEL	656-657	CHAMPÚ PREVENCIÓN CAÍDA	517
ACTIVADORES	28-29	CHAMPUS	141,146-147,153-154
ADHESIVO FIJAR CORTINA CABELLO	384	CHAMPUS CAPTAIN COOK	498
ADHESIVOS PESTAÑAS	773	CHAMPUS Y MASCARILLAS	142-143,145,155-157
AFEITADORA BARBER LINE	433	CILINDRO PARA BROCHAS Y PINCEL	747
AFEITADORA CAPTAIN COOK	434	CINTURON PORTA-ÚTILES	398
AFEITADORA RAGNAR	432	CLIPS	169-173,383
AFTER SHAVES MYRSOL	513	CLIPS CON PERLAS	200-201
AFTER SHAVES SPLASH	508	CLIPS Y HORQUILLAS	174
AGUA MICELAR	580	CLIPS Y PINZAS	188
AGUJAS ELÉCTRICAS	636	COCTELERAS Y MEDIDORES	75
ALFOMBRÁ DESINFEC. CALZADO	791	COJINES ESPECIALES PARA NIÑOS	220,530
ALFOMBRILLA BARBERIA CAPTAIN	437	COLGADOR BOLSO	400
ALFOMBRILLA BARBERIA RAGNAR	437	COLGADOR VENTOSA	339
ALGODON	387,791-792	CONJUNTO MONOMANDO LAVACABEZAS	244
ALICATE CORTA CUTÍCULAS	711	CONJUNTO MONOMANDO Y DUCHA	536
ALICATE CORTAÚNAS	711	CONTENEDOR PARA TIJERAS	377
ALICATE CORTAÚNAS ARTIFICIALES	718	CONTENEDOR TOALLAS	535,839
ALICATE PARA EXTENSIONES	385	CORTA-CABELLOS	377
ALICATES CORTA CUTÍCULAS	712-715,717	CORTA-CABELLOS Y NAVAJAS	378-379
ALICATES CORTAÚNAS	716	CORTAÚNAS	718
AMPOLLAS PREVENCIÓN CAÍDA	517	CORTINAS CABELLO	381
ANILLAS	382	COSMÉTICA POST DEPILACIÓN	634-635
ANTICELULÍTICAS Y REAFIRMANTES	605	CREMA CAPTAIN COOK	499
ARO LUZ LED	808-809	CREMA DE MANOS	660
ASPIRADOR DE CABELLO	57,442	CREMAS CAPTAIN COOK	505
ATOMIZADOR DE FIBRAS CAPILARES	518	CREMAS Y TRATAMIENTOS	583-585,587,589
		CUCHILLAS	457-459
		CURLS ROCK CREMA	503
BÁLSAMO PARA BARBA	509		
BÁLSAMO PARA BIGOTE	509	DECOLORANTES	139-141
BACÍA JABÓN AFEITADO	476	DELANTAL BARBER LINE	546
BAJA PIELS	724	DELANTAL CAPTAIN COOK	547
BALANZAS	62-63	DELANTAL PARA BROCHAS Y PINCEL	747
BANDAS DEPILAR	631-633	DELANTALES	103
BASTÓN DE MASAJE VIBRATORIO	607	DESINFECTANTE, ESTERILIZADORES	563-565
BATAS Y KIMONOS	102	DIFUSORES	26-27
BIGUDIES MADERA	331	DISOLVENTES	384
BIGUDIES PLÁSTICO	332-334	DISPENSADOR	80
BLACK MASK LIMPIEZA PROFUNDA	580	DISPENSADOR PEINES UN USO	297
BOLES	64-67	DISPENSADORES	409
BOLSA APLICADORES SOMBRA	759	DISPENSADORES GEL	568
BOLSA DE CLIPS EXTENSIONES	384	DUCHA CON SOPORTE	243,535
BOLSA DE GANCHOS PARA ANILLAS	385	DUCHA CON SOPORTE LAVACABEZAS	244,536
BOLSA DISCOS PARA EXTENSIONES	385	DUCHA LAVACABEZAS NEGRO	244,536
BOLSA GANCHILLOS	350		
BOLSA GANCHOS MECHAS	350	EMPUJADORES	720
BOLSA PINCHITOS	343	EMULSION AFEITADO SIN ALCOHOL	513
BOTELLAS APLICADORAS GRADUADAS BOTES	76	ESCALERILLA MADERA SPA	826
PEINES COLORES	315-319	ESCOBAS	569
BROCHA COLORETE ANGLED	747	ESCOBAS DE GOMA	410
BROCHAS	476	ESMALTE P-LACK	653-655
BROCHAS MAQUILLAJE POLLÍE	748	ESMALTE POLLÍE	647-651
BROCHAS Y PINCELES MAQUILLAJE	749-751,754	ESPECÍFICOS PEDICURA	725-735
		ESPEJOS	400,531,566,793-799
CABEZA MANIQUÍ CABELLO NATURAL	207-209	ESPONJAS DESMAQUILLAR	742-743
CABEZAL DE DUCHA CROMADO	244,536	ESPONJAS KONJAC	599
CABEZAL DUCHA IÓNICO	243,535	ESPONJAS MAQUILLAJE	744-746
CABEZAS CABELLO SINTÉTICO	212-213	ESPUMA DE AFEITAR	461
CABEZAS MANIQUÍ BARBER LINE	572	ESTERILIZADORES	54-56,443-445,709-710
CABEZAS MANIQUÍ BERGMANN	214	ESTUCHE PINCELES MAQUILLAJE	760-761
CABEZAS MANIQUÍ EUROSTIL	571-572	ESTUCHE PORTA ÚTILES NEGRO	397
CAJA ORGANIZADORA (VACÍA)	399	ESTUCHES PEINES	302-303
CAJA PINCHITOS	343	ESTUCHES TIJERAS	374-376
CAMILLAS	823-826	EXFOLIANTE CORPORAL	604
CAPA DE CORTE CAPTAIN COOK	547	EXFOLIANTE FACIAL	580
CAPAS	90-101,543-545	EXPOSITOR FIBRAS CAPILARES	519
CAPAS INFANTILES	104-105	EXPOSITOR MADERA 20 CEPILLOS	254
CAPAS UN SOLO USO	86-89	EXPOSITOR PESTAÑAS ANDREA	774
CAPTAIN COOK	498-504	EXPOSITOR PINCELES	758
CARRITO MANICURA/PEDICURA	830	EXPOSITOR RETOCA-RAÍCES RAGNAR	497
CARRITOS	240-242	EXPOSITOR TASSEL ACTIVE CELLS	586
CARRITOS Y BIDÓN	532	EXPOSITOR TASSEL PROFESSIONAL	588
CASCO SECADOR VALERA	34	EXPOSITOR TIJERAS	377
CEJAS ANDREA	775	EXPOSITORES	740
CEPILLO BARBA RAGNAR	478	EXPOSITORES ACEITES ESENCIALES	591
CEPILLO BARBER LINE	479	EXPOSITORES CAPTAIN COOK	506
CEPILLO CIRCULAR	286	EXPOSITORES CEPILLOS	268,270-271
CEPILLO CIRCULAR DE MADERA	249-251	EYELINER	741
CEPILLO CIRCULAR DE PLÁSTICO	249		
CEPILLO DESENREDAR	267	FIBRAS CAPILARES	164,518
CEPILLO ELÉCTRICO TÉRMICO	52	FIJACIÓN DE EFECTO SECO	502
CEPILLO ESFÉRICO 3D	269	FUNDAS CORTA UÑAS Y GUBIAS	719
CEPILLO FUELLE DESENREDAR	257	FUNDAS Y PAPEL CAMILLA	777
CEPILLO FUELLE MANGO MADERA	252	FUNDAS Y TOALLAS	778-779
CEPILLO FUELLE MANGO PLÁSTICO	258-263	FUSOR CERA NEGRO BARBER LINE	441
CEPILLO LIMPIA-PEINES	495	FUSORES	617-620
CEPILLO MADERA MANGO GOMA	252	FUSORES GRANDES	621
CEPILLO PARA CHAMPÚ MASAJEADOR	319		
CEPILLO PROFESIONAL OVALADO	259	GAFA PROTECTORA ANTIVAHÓ	791
CEPILLO RAGNAR	481	GEL ELECTROCONDUCTOR	637
CEPILLO TÉRMICO	286	GEL THE LEGENDS	516
CEPILLOS	784	GOMAS Y COLETEROS	192-198
CEPILLOS BAMBÚ	255	GORROS	344,346-349,351
CEPILLOS BARBER LINE	480-481	GRAPAS	189-191
CEPILLOS BARBERO	475	GUANTES	81-83
CEPILLOS CREPAR	247	GUANTES Y ACCESORIOS	560-561
CEPILLOS ESPIRALES	248		
CEPILLOS ESQUELETOS	272-276	HIGIENE Y DESINFECTANTES	818-821
CEPILLOS EUROSTIL	482-483	HORQUILLAS	175-180
CEPILLOS FUELLE MANGO GOMA	264-265		
CEPILLOS FUELLE MANGO MADERA	253-254,256	JOFAINAS Y FUNDAS LAVACABEZAS	74
CEPILLOS NEUMÁTICO	266		

JUEGO DUCHA ADAPTABLE	243,535	PEINES PROFESIONALES MATADOR	307-309
KIMONO ANTIESTÁTICO	117	PEINES PROFESIONALES POLLIE	305-306
KIT EXFOLIANTE CORPORAL/FACIAL	604	PEINES PROFESIONALES SILKOMB	310
KIT EXTENSIONES	385	PEINES RAGNAR	485-488
KIT PESTAÑAS ANDREA STARTER	771	PEINES SILKOMB	P494
KIT RIZADOR PELO	339	PEINES VARIOS COLORES	311-314
KITS DE DEPILACIÓN POLLIE	630	PEN RAZOR	461
KITS DE PESTAÑAS	772	PESTAÑAS ANDREA	767-768
LÁMPARA MESA MANICURA	830	PESTAÑAS ANDREA SM	769
LÁMPARAS	673-678	PESTAÑAS COMPLETAS ANDREA	770-771
LÁPICES PLÁSTICO POLLIE	737	PESTAÑAS POLLIE	63-766
LÁPIZ MADERA CEJAS POLLIE	740	PINCELES	759
LÁPIZ MADERA LABIOS POLLIE	739	PINCELES GEL Y ACRÍLICO	661-662
LÁPIZ OJOS MADERA POLLIE	738	PINCELES KABUKI	752-753
LÍNEA ARGÁN	146	PINCELES MANGO MADERA	755-757
LÍNEA AROMA SENSATION	149-152	PINZA INOX. USO GENERAL	784
LÍNEA DE CEPILLOS IONIC	281	PINZAS	181-187
LÍNEA HYALURONIC COSMÉTICA	581-582	PINZAS DEPILAR	640-645
LÍNEA PIELS GASAS ASTRINGENTE	590	PLANCHAS PEQUEÑA BARBER LINE	441
LÍNEA PRODUCTOS MAT. RECICLADO	327-329	PLANCHAS	35-45
LÍQUIDO TRATAMIENTO VENDA FRÍA	608	POLO BARBERO	521
LACA FIBRAS CAPILARES	519	POLVO VOLUMINIZADOR GRAVITY	504
LACAS CAPTAIN COOK	503	POMADA THE LEGENDS	P 516
LACLA CASACAS	107-110	POMADAS CAPTAIN COOK	500-502
LACLA ESTOLAS	111-117	PORTA PELUCAS	401
LACLA PANTALONES	118-119	PORTA SECADOR	25
LAVACABEZAS	224-229,527-528	PORTAROLLO PAPEL DE CUELLO	541
LAVACABEZAS PORTÁTILES	238-239	PORTÁTILES	562
LECHE LIMPIADORA	579	PORTÁTILES SILICONA	399
LIMAS Y BLOQUES PULIR	692-708	PRODUCTOS DE ACABADO	158-167
LIMPIADOR SILICONA PINCELES	760	PROTECTOR	81
LIMPIEZA E HIGIENE	405-408	PROTECTOR FACIAL	400
LOCIÓN CAPILAR VITALIZANTE	515	PROTECTOR FACIAL FACEPRO	399
LOCIÓN HIDRATANTE BODY MILK	606	PROTECTOR OREJAS	541
LUPAS	690-691	PROTECTORES	80,567
MÁQUINAS CORTE CAPTAIN COOK	422-423	PROTECTORES DE OJOS	541
MÁQUINAS CORTE EUROSTIL	424-425	PROTECTORES RAYOS UV	817
MÁQUINAS CORTE RAGNAR	416-421	PROTECTORES Y GUANTES	781-783
MÁQUINAS RECORTE EUROSTIL	424	PULVERIZADORES	401-403,552-555,816
MÁQUINAS RETOQUE CAPTAIN COOK	427-428,431	QUITAESMALTES	658-660
MÁQUINAS RETOQUE EUROSTIL	425	RECAMBIO GOMA RIZA PESTAÑAS	774
MÁQUINAS RETOQUE RAGNAR	426	RECAMBIOS PARA TORNOS	688-689
MÁQUINAS RETOQUE RAGNAR 360º	430	RECAMBIOS TORNOS	684
MÁSCARA DE PESTAÑAS	741	RECAMBIOS TORNOS MANICURA	683
MALETAS	556-557,810-815	RED SECADOR TRIANGULAR	345
MALETAS Y BOLSAS	388-396	REDES INVISIBLES	352
MALETINES Y SILLAS MAQUILLAJE	837-838	REDUCTOR DE FLUJO DE AGUA	245,537
MANGO PARA ESCOBA	410	RELLENOS DE MOÑO	353-357
MANIQUÍ HOMBRE CABELLO NATURAL	210-211	REPOSAPIES METAL	222
MAQUINILLAS RASURAR	638-639	RETOCA-RAICES RAGNAR	497
MASAJES MYRSOL	512,514-515	RIZA PESTAÑAS	774
MASCARILLA FACIAL	596	ROLL-ON CERA HOMBRE	519
MASCARILLA HYALURONIC	44	ROLLO VENDAS FRÍAS	608
MASCARILLAS FACIALES	800	RULOS	336-343
MASCARILLAS FACIALES LACLA	801	SACAPUNTAS	759
MECHONES	772	SECADOR CASCO ORLA	33
MECHÓN PESTAÑAS SIN NUDOS	771	SECADORES	9-24,438-440
MESAS MANICURA	828-829	SECADORES CASCO	30-31
MEZCLADORA RECARGABLE TINTE	53	SEPARADORES PARA EL CABELLO	541
MOBILIARIO COMPLEMENTARIO	827	SET DE AFEITADO BARBER LINE	478
MOBILIARIO RECEPCIÓN	831	SILLA ESPECIAL PARA NIÑOS	530
MONOMANDO PARA LAVACABEZAS	243,535	SILLAS	223
MOSTRADORES RECEPCIÓN Y OTROS	533-534	SILLAS DE PELUQUERÍA	230-232,234-237
MOSTRADORES Y ESPEJOS	217-218	SILLAS NIÑOS	529
MR.BEAR FAMILY	509	SILLAS PARA NIÑOS	219-220
MUÑEQUERA IMANTADA	181	SILLONES DE PELUQUERÍA	233
MUESTRARIO COLOR EXTENSIONES	385	SILLÓN BARBERO	522-526
MYRSOL	512-515	SOLDADOR TENACILLA EXTENSIONES	53
NARICEROS EUROSTIL	435	SOPORTES Y TRIPODES	215,573
NAVAJAS BARBER LINE	449-452	TABURETES	221-222
NAVAJAS CAPTAIN COOK	453-454	TABURETES, SILLAS Y SOPORTES	832-836
NAVAJAS DESECHABLES	460	TALCO	477
NAVAJAS DESECHABLES POLLIE	377	TARJETERO ALUMINIO	400
NAVAJAS EUROSTIL	455	TASSEL	517-519
NAVAJAS FEATHER Y CUCHILLAS	456	TEMPORIZADORES	62
NAVAJAS POLLIE PARA CEJA	775	TENACILLAS RIZADORAS	46-51
NAVAJAS RAGNAR	447-448	THE LEGENDS	516
ORGANIZADOR COLGAR TOALLAS	535	THE SHAVING CO	507-508,510
ORGANIZADOR PARA COLGAR TOALLA	243	TIJERA FILO NAVAJA	366
ORGANIZADOR TOALLAS	839	TIJERA PARA ZURDOS	366
OSMA	511	TIJERAS BARBER LINE	463,469
OXIDANTE CAPILAR	132-135	TIJERAS CAPTAIN COOK	466-468
PACK BARBA CAPTAIN COOK	504	TIJERAS ESPECIAL ACADEMIA	373
PACK CABELLO CAPTAIN COOK	504	TIJERAS ESPECIAL ZURDOS	473
PACKS CAPTAIN COOK	429	TIJERAS EUROSTIL	470-471
PALETINAS	68-73	TIJERAS INICIACIÓN	373
PAPEL ALUMINIO	77-79	TIJERAS INICIACIÓN	372,472
PAPEL CUELLO	539-540	TIJERAS PIELS Y UNAS	722-723
PAPEL PERMANENTE	204-205	TIJERAS PROFESIONALES	361-365,367-372
PAPILLOTS	335	TIJERAS RAGNAR	464-465
PARAFINA	679	TIJERAS TITANIO Y DECORADAS	359-360
PEINADORES	84-85	TINTE BRIGHT COLOUR	121-132
PEINADORES Y CAPAS	542	TINTE CAPILAR	136-138
PEINE AHUECADOR DE MADERA	324	TIRAS MECHAS	61-62
PEINE BATIDOR CONCHA ACETATO	324	TOALLAS	404,558-559,784
PEINE CON NIVELES	280,495	TOALLAS CELULOSA Y SPUNLACE	203
PEINE ELÉCTRICO ANTIPIOJOS	52	TOALLAS SPUNLACE	204,780-781
PEINE ESPECIAL BARBA	428	TÓNICO REVITALIZANTE	579
PEINE ESPECIAL MECHAS	350	TORNOS MANICURA/PEDICURA	681-682,686-687
PEINE PUJA METAL GANCHO MECHAS	350	TRATAMIENTOS DE UNAS POLLIE	372
PEINES ACETATO	325-326	TUBO DESAGUE LAVACABEZAS	245,537
PEINES AHUECADOR	322-323	TUBO FLEXIBLE NYLON DUCHA	245,537
PEINES ANÓNIMOS	301	TUBO FLEXIBLE PVC DUCHA	245,537
PEINES BARBER LINE	491	TURBANTES	199
PEINES CAPTAIN COOK	489-490	UN SOLO USO	785-791
PEINES CARBONO	299-300,493	VÁLVULA FREGADERO LAVACABEZAS	244,536
PEINES COLOR MADERA	320-321	VAPORALES Y ACCESORIOS	597-598
PEINES EUROSTIL	492	VAPORIZADOR EUROSTIL	33
PEINES LENDRERAS/CEPILLOS BABY	279	VAPORIZADORES CERIOTTI	32
PEINES PEGASUS	304	VESTIMENTA/UNIFORMES LACLA	802-807
PEINES PROFESIONALES EUROSTIL	287-296,298	VESTUARIO MASCULINO LACLA	548-551

ACCESSORIES	817	COSMETIC HYALURONIC LINE	CO582
ACCESSORIES WAX	622-623	COTTON	387,791-792
ACETAT COMBS	325-326	COVERS AND MASSAGE TABLE PAPER	777
ACRYLIC GEL	656-657	COVERS AND TOWELS	778-779
ACTIVATORS	28-29	CREAM CURLS ROCK	503
ADHESIVE TO FIX HAIR WEFTS	384	CREAMS AND TREATMENTS	583-585,587,589
ALCOHOL-FREE SHAVING EMULSIO	513	CURLER EYELASHES	774
ALUMINIUM CARD CASE	400	CURLING TONGS	46-51
ALUMINIUM THERMAL BRUSHE	285	CUSHION BRUSH PLASTIC HANDLE	258-263
ALUMINIUM FOIL	77-79	CUSHION BRUSH RUBBER HANDLE	264-265
ALUMINIUM RINGS	382	CUSHION BRUSH WOODEN HANDLE	252
ANDREA EYEBROWS	775	CUSHION BRUSHES WOODEN HANDLE	253-254,256
ANDREA EYELASHES	767-768	CUTICLE NIPPER	711
ANDREA EYELASHES DISPLAY	774	CUTICLE NIPPERS	712-715,717
ANDREA FULL EYELASHES	770-771	CUTICLE PUSHERS	720
ANDREA SM EYELASHES	769	CYLINDER FOR BRUSHES/PENCILS	747
ANDREA STARTER EYELASH KIT	771		
ANGLED BLUSH BRUSH	747		
ANONYMOUS COMBS	301	DETANGLER CUSHION BRUSH	257
ANTI-CELLULITE AND FIRING	605	DETANGLING BRUSH 267	267
ANTI-FOG PROTECTIVE GOGGLES	791	DIFFUSERS	26-27
ANTIESTATIC KIMONO	117	DISINFECTANT, STERILIZERS	563-565
APRON FOR BRUSHES AND PENCILS	747	DISPENSER	80
APRONS	103	DISPENSER DISPOSABLE COMBS	297
ARGAN LINE	146	DISPENSER NECK PAPER	541
AROMA SENSATION LINE	149-152	DISPENSERS	409
ASTRINGENT LINE OIL SKIN	590	DISPLAY BRUSHES	268,270-271
		DISPLAY ESSENTIAL OILS	591
		DISPLAY OF 20 WOODEN BRUSHES	254
		DISPLAYS	740
BAG CLIPS EXTENSIONS	384	DISPOSABLE CAPES	86-89
BAG EYESHADOW BRUSHES	759	DISPOSABLE RAZORS 460	460
BAG HANGER	400	DRILL MANICURE/PEDICURE	681-682,686-687
BAG HOOK FOR RINGS	385	DRY EFFECT FIXING	502
BAG HOOKS	350	DYEING ACCESSORIES	59-60
BAG PROTECTORS HAIR EXTENSIONS	385	DYEING BRUSHES	68-73
BAG STREAKS HOOKS	350		
BAMBOO BRUSHES	255		
BARBER ARMCHAIR	522-526	EAR HOOD	541
BARBER BRUSHES	475	ELASTIC HAIR BANDS	192-198
BARBER LINE APRON	546	ELECTRIC COMB ANTI LICE	52
BARBER LINE BARBER SHAVING	478	ELECTRIC NEEDLES	636
BARBER LINE BLACK WAX HEATER	441	ELECTROCONDUCTOR GEL	637
BARBER LINE BRUSH	479	ESSENTIAL OILS	592-595
BARBER LINE BRUSHES	480-481	EUROSTIL BRUSHES	482-483
BARBER LINE COMBS	491	EUROSTIL COMBS	492
BARBER LINE MANNEQUIN HEAD	572	EUROSTIL HAIR CLIPPERS	424-425
BARBER LINE RAZORS	449-452	EUROSTIL MANNEQUIN HEAD	571-572
BARBER LINE SCISSORS	463,469	EUROSTIL NOSE HAIR CLIPPER	435
BARBER LINE SHAVER	433	EUROSTIL PROFESSIONAL COMBS	287-296,298
BARBER LINE SMALL STRAIGHTENER	441	EUROSTIL RAZORS	455
BARBER POLE	521	EUROSTIL RETOUCH CLIPPERS	424-425
BASE OILS	601-603	EUROSTIL SCISSORS	470-471
BEARD BALM	509	EUROSTIL VAPORIZER	33
BEARD OIL	509	EXTENSIONS KIT	385
BELT FOR TOOLS	398	EYELASHES ADHESIVES	773
BIG WAX HEATERS	621	EYELASHES KITS	772
BLACK MASK DEEP CLEANING	580	EYELASHES LOCKS	772
BLACK PURSE FOR TOOLS	397	EYELASHES MASK	741
BLACK SHOWER WASH BASIN	244,536	EYELINER	741
BLEACHING POWDER	139-141		
BODY AND FACIAL PEELING KIT	604	FACEPRO FACE PROTECTOR	399
BODY SCRUB	604	FACIAL MASK	596
BOURBON 1874 SHAMPOO	504	FACIAL MASKS	800
BOWL FOR SHAVING SOAP	476	FACIAL SCRUB	580
BOWLS	64-67	FALSE NAILS CLIPPER	718
BRIGHT COLOUR DYE	121-132	FEATHER RAZORS AND BLADES	456
BROOM HANDLE	410	FINISHING PRODUCTS	158-167
BROOMS	569	FLEXIBLE NYLON SHOWER TUBE	245,537
BRUSH CLEAN COMBS	495	FRONT DESKS AND MIRRORS	217-218
BRUSHES	476,759,784	FURNITURE RECEPTION	831
BRUSHES DISPLAY	758		
		GEL AND ACRYLIC BRUSHES	661-662
CAPIES	90-101,543-545	GEL DISPENSERS	568
CAPS	344,346-349,351	GEL THE LEGENDS	516
CAPTAIN COOK	498-504,508	GLOVES	81-83
CAPTAIN COOK APRON	547	GLOVES AND ACCESSORIES	560-561
CAPTAIN COOK BARBER RUG	437	GOWN AND CAPE	542
CAPTAIN COOK BEARD PACK	504	GOWNS	84-85
CAPTAIN COOK COMBS	489-490	GRAVITY VOLUMIZER DUST	504
CAPTAIN COOK CREAM	499		
CAPTAIN COOK CREAMS	505	H.D. NET TRIANGLE	345
CAPTAIN COOK CUTTING CAPE	547	HAEMOSTATIC MATCHES	516
CAPTAIN COOK DISPLAYS	506	HAIR BURN STUFF	353-357
CAPTAIN COOK HAIR CLIPPERS	422-423	HAIR CURLER KIT	339
CAPTAIN COOK HAIR PACK	504	HAIR CUTTER	377
CAPTAIN COOK HAIR POMADES	500-502	HAIR CUTTER AND RAZORS	378-379
CAPTAIN COOK LACQUERS	503	HAIR DRYER HOLDER	25
CAPTAIN COOK OIL	505	HAIR DRYERS	9-24,438-440
CAPTAIN COOK RAZORS	453-454	HAIR DYE	136-138
CAPTAIN COOK RETOUCH CLIPPERS	427-428	HAIR FIBER ATOMIZER	518
CAPTAIN COOK SCISSORS	466-468	HAIR FIBERS	164,518
CAPTAIN COOK SHAMPOO	499	HAIR FIBERS SPRAY	519
CAPTAIN COOK SHAMPOOS	498	HAIR FIBRES EXHIBITOR	519
CAPTAIN COOK SHAVER	434	HAIR GRIPS	189-191
CAPTAIN COOK WAX	505	HAIR GRIPS WITH PEARLS	200-201
CAPTAINCOOK RETOUCHING MACHINE	431	HAIR LOSS PREVENTION SHAMPOO	517
CARBON COMBS	299-300,493	HAIR LOSS PREVENTION VIALS	517
CASES	388-396	HAIR OXIDANT	132-135
CELLULOSE TOWELS AND SPUNLACE	203	HAIR REMOVAL STRIPS	631-633
CERAMIC THERMAL BRUSH	282	HAIR REMOVAL TWEEZERS	640-645
CERIOTTI VAPORIZERS	32	HAIR STRAIGHTENER BRUSHES	278
CHAIRS	223	HAIR STRAIGHTENERS	35-45
CHILDREN'S SEATS	219-220,529	HAIR VACUUM	57,442
CHROME SHOWER HEAD	244,536	HAIR WEFTS	381
CIRCULAR BRUSH	286	HAIRDRESSING ARMCHAIRS	233
CIRCULAR PLASTIC BRUSH	249	HAIRDRESSING CHAIRS	230-232,234-237
CIRCULAR WOODEN BRUSH	249-251	HAIRPINS	175-180
CLEANSING MILK	579	HAND CREAM	660
CLIPS	169-173,181-187,383	HEADS SYNTHETIC HAIR	212-213
CLIPS AND HAIRPINS	174,188	HELMET HAIR DRYERS	30-31
COATS AND KIMONOS	102	HIGIENIC AND DISINFECTANTS	818-821
COILS	335	HOLDERS AND TRIPODS	215
COLD BANDAGE TREATMENT LIQUID	608	HYALURONIC MASK	144
COMB WITH LEVELS	280,495	HYALURONIC SHAMPOO	144
COMBS BINS	315-319	HYGIENE ITEMS	405-408
COMBS SETS	302-303		
COMPLEMENTARY FURNITURE	827	INITIATION SCISSORS	372-373,472
CONNECTOR FOR HAIR EXTENSIONS	53	INOX TWEEZER MULTI PURPOSE	1784
COSMETIC HYALURONIC LINE	581	INVISIBLE HAIRNETS	352
COSMETIC ACCESSORIES	609,680	IONIC BRUSH LINE	281





C/Ciudad de Asunción 56 · Barcelona 08030 (Spain)  
Tel. +34 93 274 07 84  
ventas@eurostil.com · export@eurostil.com